

TOP VIEW

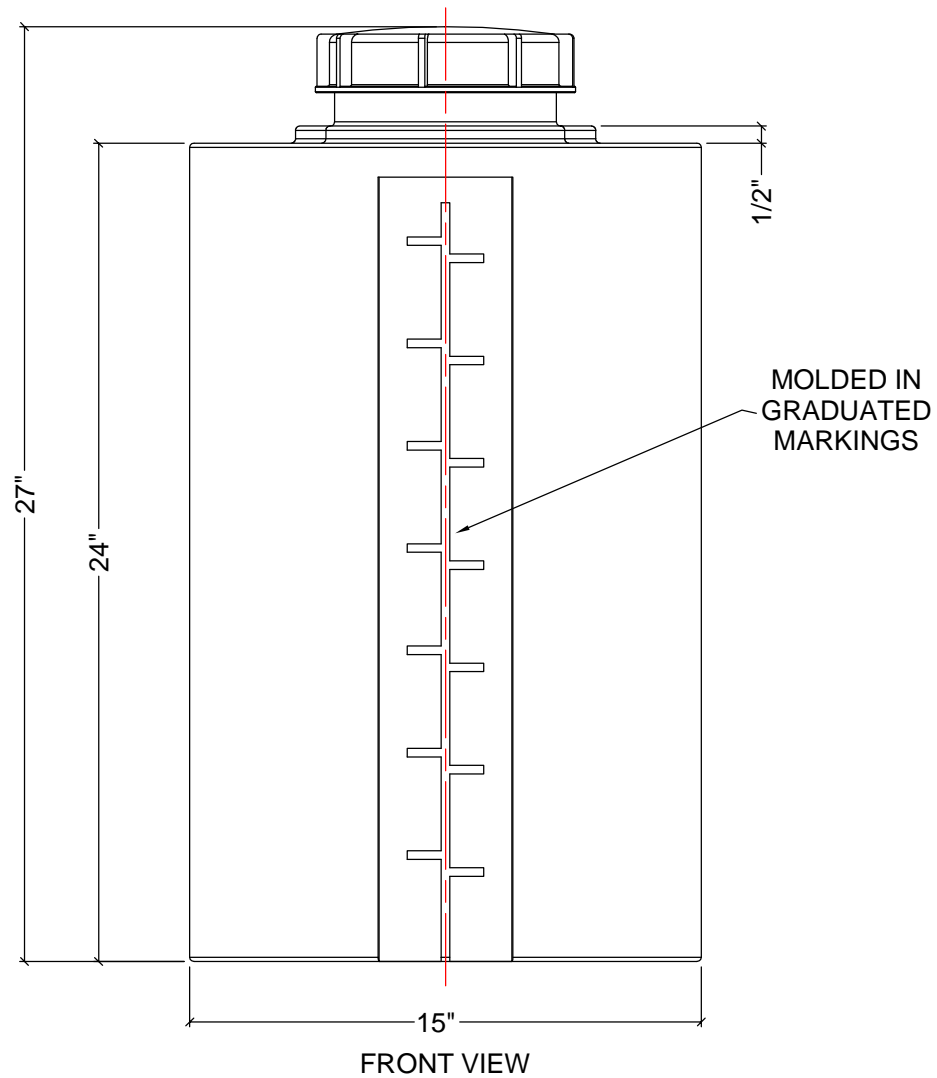
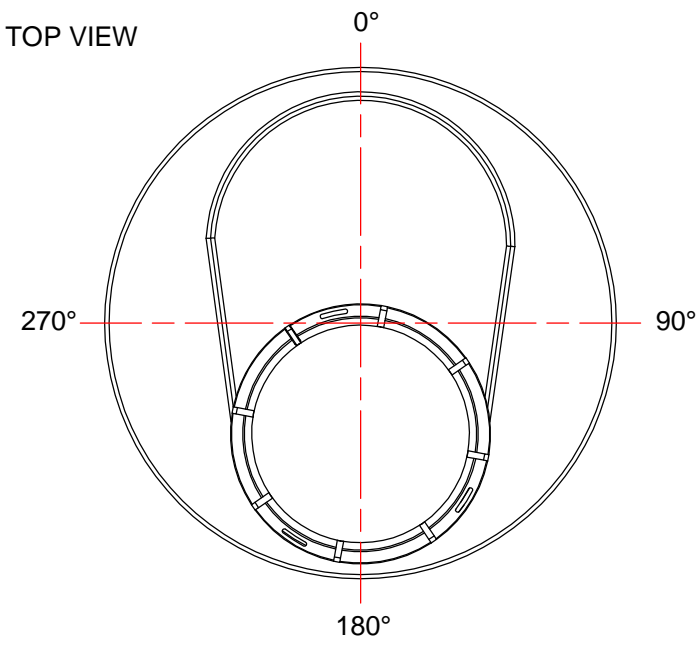

FRONT VIEW

NOTES:

1. TANK IS MANUFACTURED TO ASTM-D-1998 STANDARD.
2. ALL DIMENSIONS ARE APPROXIMATE.

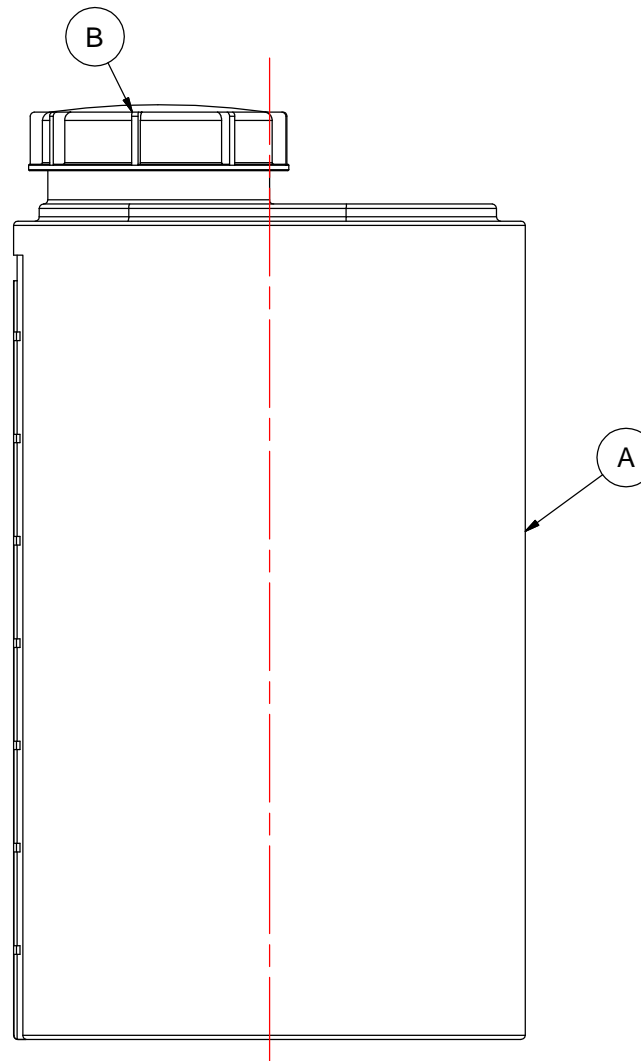

SIDE VIEW

MATERIALS LIST		
ITEMS	DESCRIPTION	NOTES
A	PTB-60 TOTE BARREL	
B	5 1/2" THREADED LID	

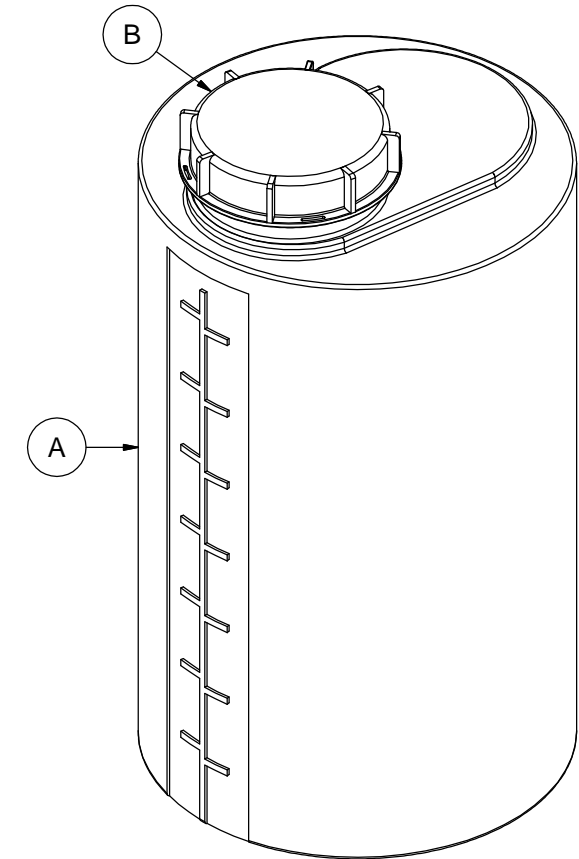

REV	DATE	DESCRIPTION	BY	APPD	REVD
1	05-07-10	ADDED GRADUATED MARKINGS	WM		

CUSTOMER

TITLE: 60 LITRE TOTE BARREL

ACO JOB NO:

PURCHASE ORDER NO:

PURCHASER'S EQUIP. NO:

THIS DRAWING IS THE PROPERTY OF ACO CONTAINER SYSTEMS LTD. AND SHALL NOT BE COPIED OR TRANSFERRED WITHOUT THE WRITTEN CONSENT OF ACO CONTAINER SYSTEMS LTD.

ENGINEERS SEAL

**ACO CONTAINER SYSTEMS LTD.**

PICKERING - ONTARIO - CANADA

ACO CONTAINER SYSTEMS LTD.  
794 MCKAY RD.  
PICKERING, ONTARIO, CANADA  
L1W 2Y4  
TEL. 905-683-8222  
FAX 905-683-2969

DESIGNED

DRAWN

CHECKED

APPROVED

SCALE

DATE

N.T.S.

19-05-09

DWG No

PTB-60

REV 1