

MATERIALS LIST		
ITEMS	DESCRIPTION	NOTES
A	OT-1000 OPEN TOP TANK	
B	LID FOR OT-1000	

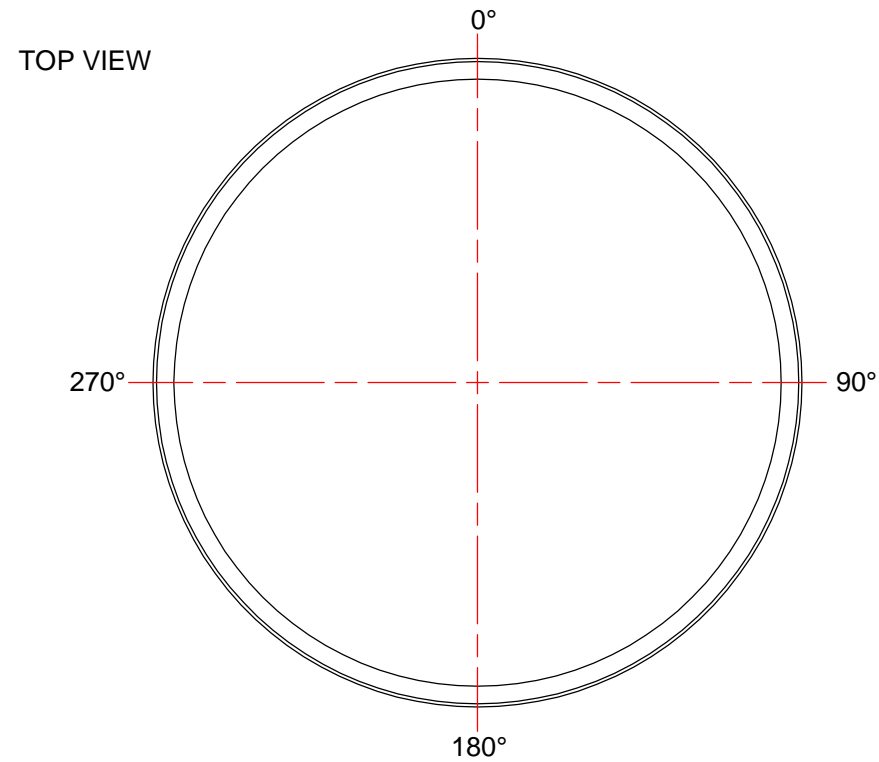

NOTES:
 1. TANK IS MANUFACTURED TO ASTM-D-1998 STANDARD.
 2. ALL DIMENSIONS ARE APPROXIMATE.

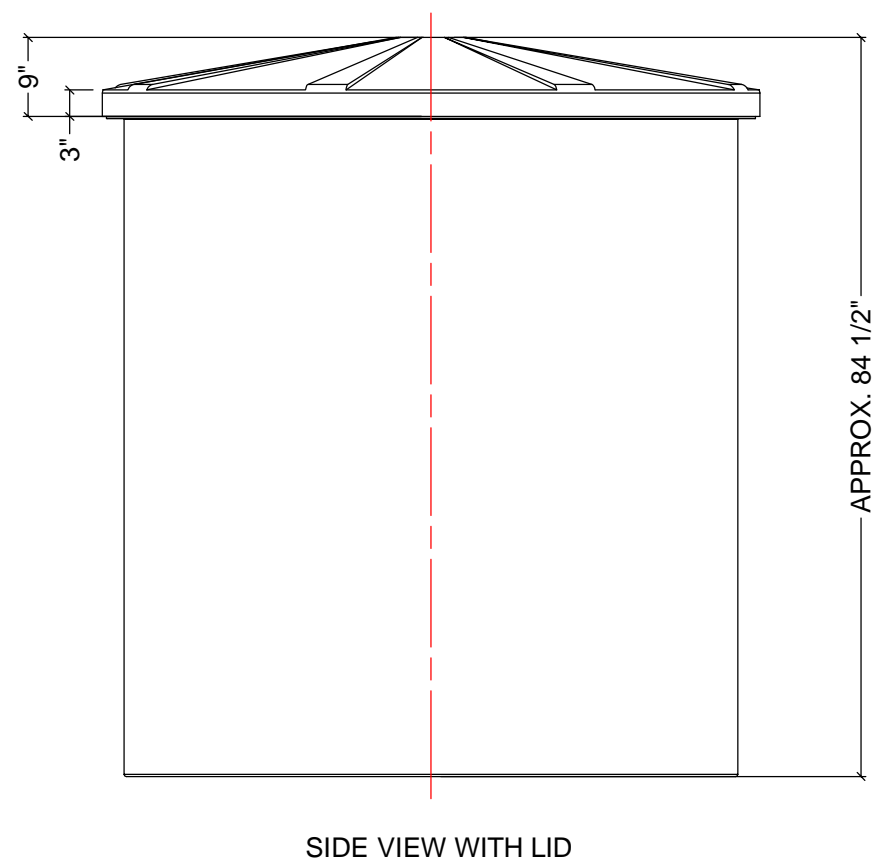
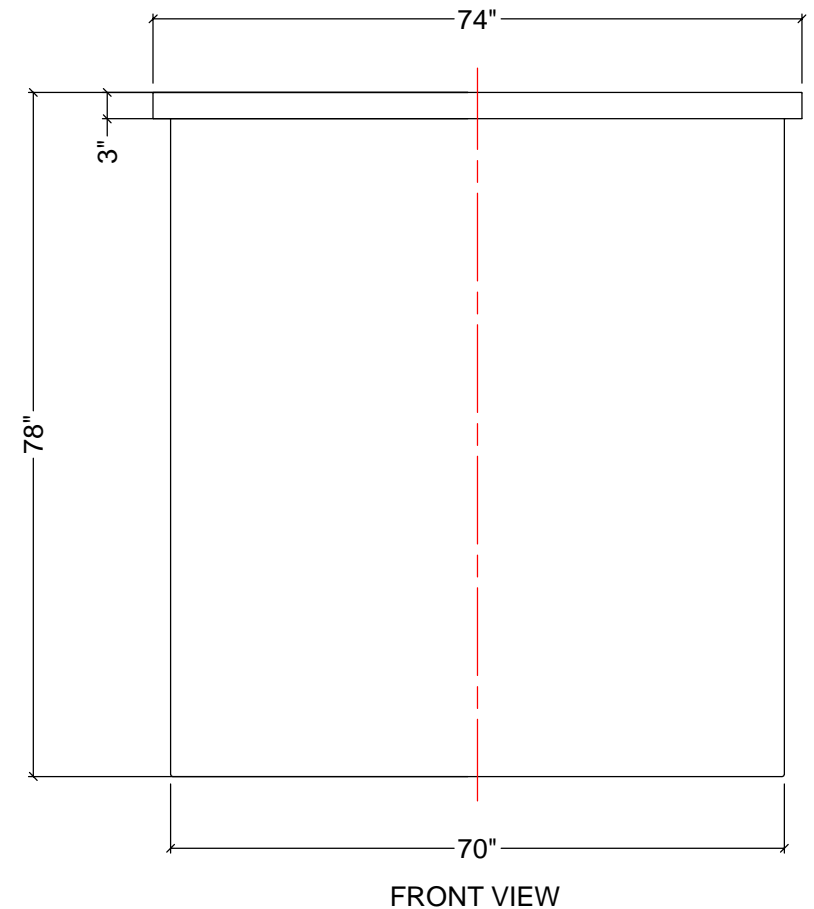
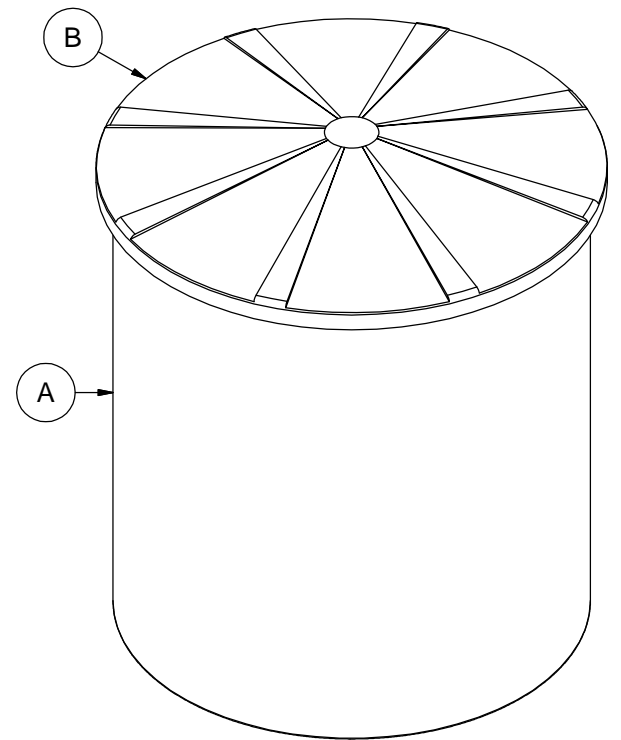
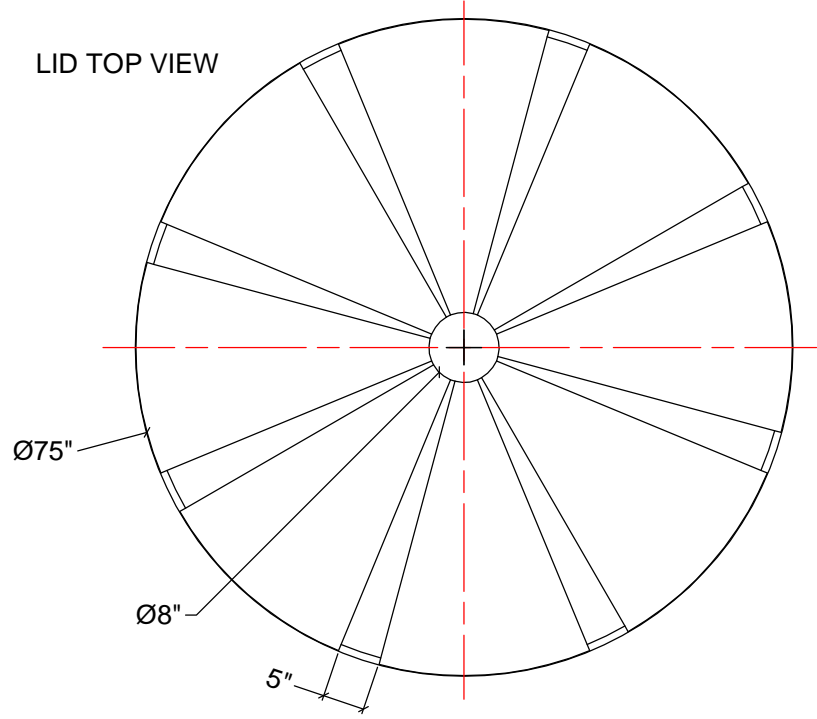

REV	DATE	DESCRIPTION	BY	APPD	REVD
REVISIONS					
CUSTOMER					
TITLE		ACO JOB NO:			
1000 I.G. OPEN TOP TANK WITH LID		PURCHASE ORDER NO:			
		PURCHASER'S EQUIP. NO:			
THIS DRAWING IS THE PROPERTY OF ACO CONTAINER SYSTEMS LTD. AND SHALL NOT BE COPIED OR TRANSFERRED WITHOUT THE WRITTEN CONSENT OF ACO CONTAINER SYSTEMS LTD.					
ENGINEERS SEAL		ACO CONTAINER SYSTEMS LTD.			
		<small>PICKERING - ONTARIO - CANADA</small>			
		<small>ACO CONTAINER SYSTEMS LTD.</small>		<small>DESIGNED</small>	
		<small>794 MCKAY RD.</small>		<small>DRAWN</small>	
		<small>PICKERING, ONTARIO, CANADA</small>		<small>CHECKED</small>	
		<small>L1W 2Y4</small>		<small>APPROVED</small>	
		<small>TEL. 905-683-8222</small>		<small>SCALE</small>	
		<small>FAX 905-683-2969</small>		<small>N.T.S.</small>	
		<small>DWG No</small>		<small>DATE</small>	
				<small>27-05-09</small>	
		OT-1000-L		REV 0	