

# EB-162



## Standard Service Retractable Injection Quill 3/4" Valve x 3/8" Tube with Integrated Check Valve

### SPECIFICATIONS

SAFETY RATING	150 PSI
CHECK VALVE	INTEGRATED SPRING LOADED BALL CHECK VALVE <sup>1</sup>
SAF-T-SEAL TIP	OPTIONAL
QUICK DISCONNECT	NO
VALVE/PROCESS CONNECTION SIZE	3/4" MNPT
INLET CONNECTION SIZE	1/2" NPT
SOLUTION TUBE SIZE	3/8"
SOLUTION TUBE ID	0.423"
SOLUTION TUBE OD	0.675"
(A) OPERATING LENGTH	11.75"
(B) VALVE/GLAND LENGTH	7.25"
EXTRACTION LENGTH	19" + INSERTION LENGTH

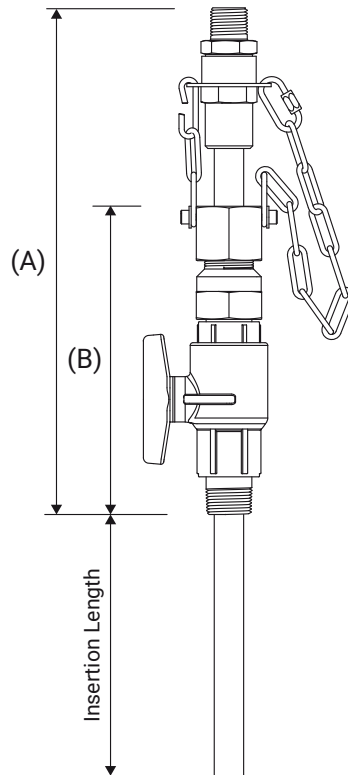

### ORDERING INFORMATION

SERIES	VALVE MATERIAL	SOLUTION TUBE MATERIAL	INSERTION LENGTH <sup>2</sup>	TIP CONFIGURATION	CHECK VALVE SEAL
EB-162	-	-	-	-	-
	C = CPVC	P = PVC C = CPVC	2 = 2" 4 = 4" 6 = 6"	0 = Standard B = 45° Bevel CV = SAF-T-Seal, FKM CE = SAF-T-Seal, EPDM	V = FKM E = EPDM K = KALREZ 6375

### TECH NOTES

1. Check valve spring cracking pressure is 10 PSI.
2. Maximum insertion length for 3/8" PVC and CPVC solution tubes is 6". PVC and CPVC solution tubes are not covered by warranty when used in process flows with velocities 6 fps or greater.