

REV.	DESCRIPTION	DATE	MOD	CHK'D
A	RELEASED	9/20/2016	CAW	LAC

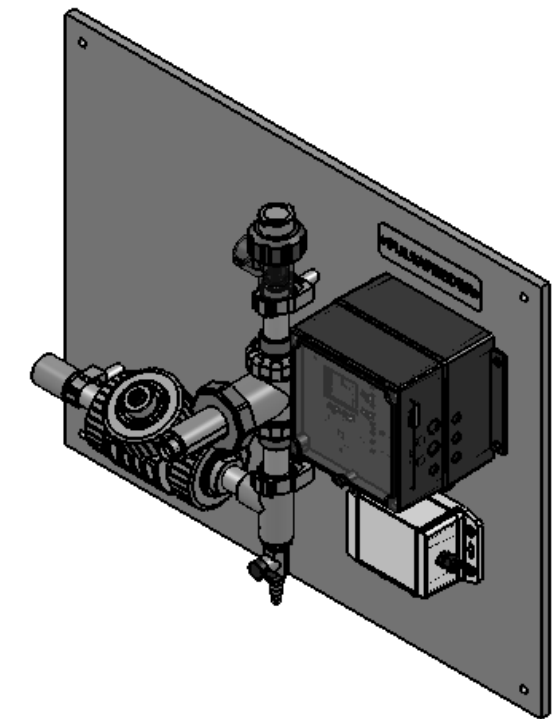
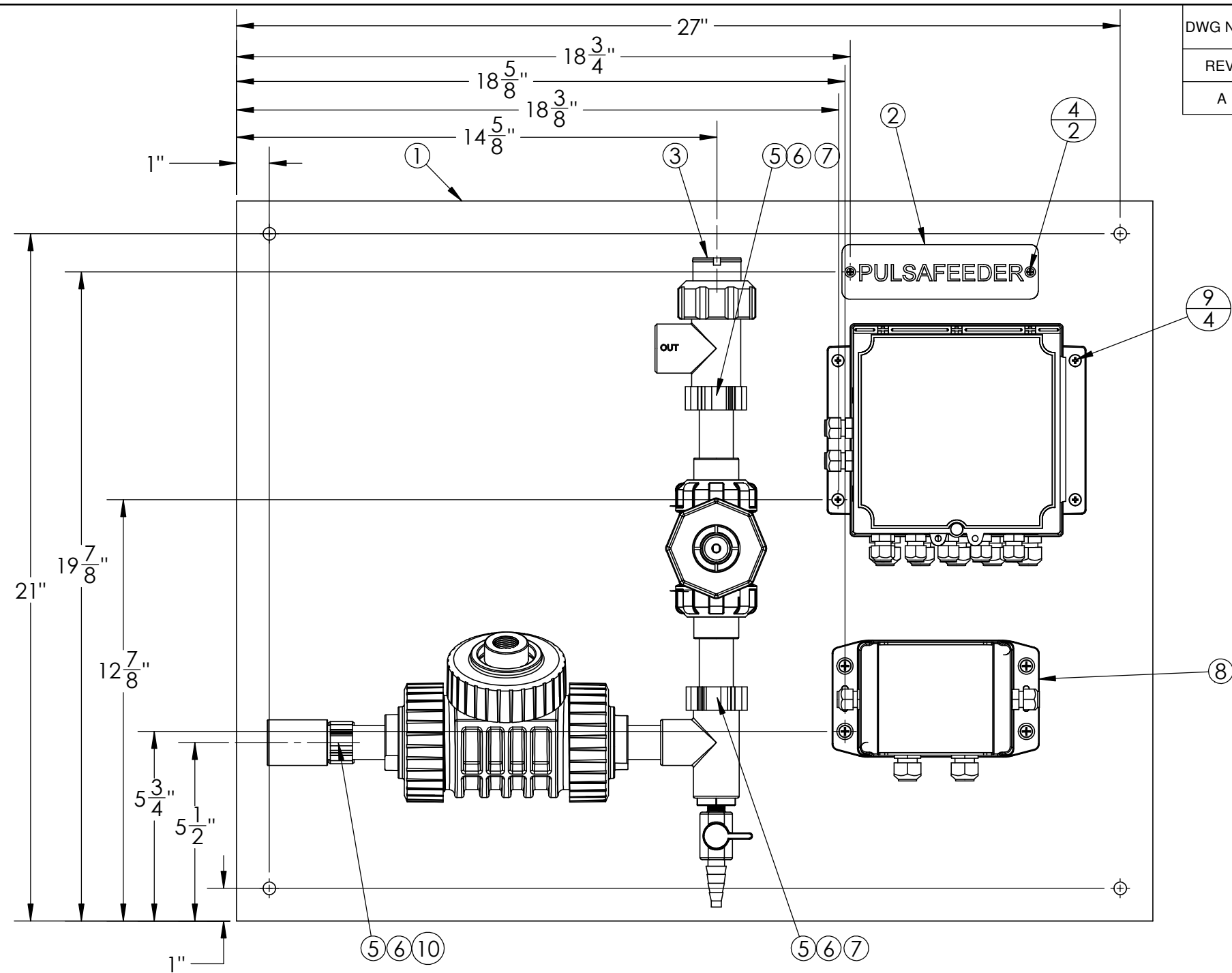

ITEM NO.	PART NUMBER	DESCRIPTION	QTY.
1	02-301-13	PANEL,22X28,POLYETHYLENE	1
2	J25334	LABEL(LEXAN), LOGO NAMEPLATE	1
3	16-600-11	PIPING ASY, PTSA PYXIS, CONDUCTIVITY	1
4	U0900857	SCR(SST),6-20 X.38 TYPE-BT PHP	2
5	U0813501	SCR,PH,SST, 10-32 1.50	3
6	06-011-02	TEE NUT,10-32,.24BARREL,3PRONG	7
7	06-058-00	SPACER(PVC),10-0, 1"- LG	2
8	72-901-10	PWR,ASSEM,4-20mA	1
9	U0811415	SCREW(SST), 10-32 X .75-LG PHP	4
10	06-056-01	SPACER(PVC), 1.25"-LG.	1

NOTES:  
1. CONTROLLER INFORMATION WILL BE ON PURCHASE ORDER/WORK INSTRUCTIONS

INTERPRET GEOMETRIC TOLERANCING PER ASME Y14.5M-1994 UNLESS OTHERWISE SPECIFIED		DWN	CAW	09/20/2016
TOLERANCE	MACHINED SURFACES ROUGHNESS	CHK	LAC	09/26/2016
X.X"	± .050"			
X.XX"	± .015"			
X.XXX"	± .005"			
ANGLES	± 0°30'			
BREAK ALL SHARP EDGES .015" MAX. ALL DIMENSIONS IN INCHES				

**PULSAFEEDER** IDEX CORPORATION

TITLE **PANEL ASSY, MVEX,PTSA, PYXIS,COND**

REV **A** SIZE **B** DWG NO **15-100-60**

FILE **15-100-60** SCALE: 1:4 SHEET **1** OF **1**

PROPRIETARY DATA: THIS DOCUMENT DISCLOSES INFORMATION AND DATA IN WHICH PULSAFEEDER HAS PROPRIETARY RIGHTS. THE RIGHT TO REPRODUCE, USE OR DISCLOSE IN WHOLE OR IN PART EXCEPT BY WRITTEN PERMISSION IS PROHIBITED.