

**750 Series II  
CONDUCTIVITY/TDS  
&  
RESISTIVITY  
MONITOR/CONTROLLER  
Operation  
Manual**

24 November 09

**INSTALLATION • OPERATION • MAINTENANCE**

**Conductivity/TDS Models: 756II, 757II, 758II & 759II**

**Resistivity Models: 751II, 752II, 753II & 754II**

**ACCURACY • RELIABILITY • SIMPLICITY**

**MYRON L  
COMPANY**  
Water Quality Instrumentation  
*Accuracy • Reliability • Simplicity*



# 750 Series II MONITOR/CONTROLLER QUICK REFERENCE GUIDE

**If you read nothing else in this manual please read this Quick Reference Guide.**

**PLEASE READ and COMPREHEND ALL WARNINGS, CAUTIONS and ADVISEMENTS CONTAINED WITHIN THIS MANUAL.**

**Failure to comply is beyond the responsibility of the Myron L Company.**

**WARNING: ALL MONITOR/CONTROLLERS ARE FACTORY SET TO OPERATE ON 115 VAC. BEFORE APPLYING POWER ENSURE THE INPUT POWER "115/230 VAC" SELECTION IS CORRECT FOR YOUR REQUIREMENTS. FAILURE TO DO SO IS BEYOND THE RESPONSIBILITY OF THE MYRON L COMPANY. See section II.E.2. and figure II.E.1.**

**NOTE: SOME MODELS MAY HAVE EITHER A 24 VAC OR A 24 VDC INPUT POWER REQUIREMENT - CHECK LABELS CAREFULLY.**

**WARNING: ENSURE POWER IS OFF WHILE INSTALLING ELECTRICAL EQUIPMENT. IF MONITOR/CONTROLLER IS INSTALLED, ENSURE THE POWER IS OFF BEFORE SERVICING. FAILURE TO DO SO COULD CAUSE DAMAGE TO THE INSTRUMENT, AND COULD BE HARMFUL OR FATAL TO PERSONNEL. ONLY QUALIFIED PERSONNEL SHOULD INSTALL OR SERVICE ELECTRICAL EQUIPMENT.**

**WARNING: THE DISPLAY WILL BE IRREPARABLY DAMAGED IF THE DISPLAY HARNESS IS INSTALLED UPSIDE-DOWN OR MISALIGNED. THE HARNESS MUST BE INSTALLED AS SHOWN IN FIGURE II.E.8.**

#### **CAUTIONS:**

Before installation, ensure you have the correct model (with options), AND it is ranged for your application. See sections I.A., I.B. & I.G. Do you have the correct sensor? See section I.E. Mounting requirements. What is needed? See section II.B.

The following will give the installer and user a quick overview. See the sections listed for details.

#### **REMOVING FRONT PANEL**

**NOTE:** When opening instrument, remove front cover with care; a ribbon cable connects the front panel and main board.

1. Ensure power is **OFF**.
2. Remove the four (4) screws on the front panel.
3. Carefully wiggle the front panel to loosen the gasket and pull gently toward you. Do not pull more than about 8 inches/20CM or you could damage the wiring harness.

#### **REASSEMBLY**

1. Carefully reinstall the front panel, bottom first. Ensure no wires have been pinched between enclosure and front panel.
2. Reinstall the four (4) screws and tighten.
3. To operate, turn power **ON**.

#### **INTRODUCTION - Section I.**

This section covers the specifications of your new Monitor/controller including sensor information.

#### **INSTALLATION - Section II.**

This section covers how to install your new Monitor/controller; mechanically and electrically.

#### **OPTIONS & ACCESSORIES - Section III.**

This section covers the specifications, installation, set up, and operation of each option.

#### **QUICK LOCATOR**

SC/SCO MODULE, (Second Relay), see section III.A.

4A/4AO MODULE (4-20mA), see section III.B.

TP/TPO MODULE (Temperature), see section III.C.

TH/THO MODULE (Alarm /control Harness), see section III.D.

DUAL (stacking) Temperature (TPO) & 4-20mA (4A/4AO), see section III.E.

3SO/3SE MODULE (3 Sensor option) , see section III.F.

3RO/3RE MODULE (3 Range option), see section III.G.

3SRO/3SRE MODULE (Combined 3 Sensor & 3 Range option), see section III.H.

PA/PAO (Piezo Alarm), see section III.I.

RA (Remote Alarm), see section III.J.

#### **OPERATING PROCEDURES - Section IV.**

This section covers a brief description of different models and their features; how they work, and how to set them up for your particular use.

#### **QUICK SET POINT CONVERSION (SPC) /**

##### **REVERSING SET POINT - See Section IV.C.1.**

Conductivity/TDS Monitor/controllers are configured to trigger the alarm relay as the conductivity/TDS reading increases. Resistivity Monitor/controllers are configured to trigger the alarm relay as the resistivity reading decreases.

To reverse:

1. Locate the jumper block for the alarm to be configured. See figure V.A.1.
2. Remove and rotate the jumpers 1/4 turn and reinstall them on their posts.

#### **QUICK CHECK-OUT PROCEDURE -**

##### **See Section IV.C.2.**

It is assumed that the Monitor/controller power is ON, that it is

connected to an appropriate Sensor, and that the Sensor is immersed in water within the range that the Monitor/controller will be required to read; and the front panel is removed.

1. Make a note of the reading on the display.
2. While pressing the Calibration/Full Scale Test Switch (FSSW), verify that the front panel display is indicating a full scale reading. If not, see Calibration, section V.C.
3. Press and hold the "SET POINT" switch on the front panel. Using a tweaker or a small screwdriver, adjust the Set Point trimmer adjustment screw on the circuit board to sweep the display from zero to full scale. (A digital display may be blank at the full scale end. This is normal.) Listen for the alarm relay to click on and off as the alarm set point moves past the water reading.
4. Adjust the alarm to the desired set point value. Release the "SET POINT" switch.

**NOTE:** For Models with SC/SCO module, repeat STEPS 3 & 4 to check out Set Point #2.

### QUICK SET POINT ADJUSTMENT -

See Section IV.C.3.

The set point setting is based upon the user's particular water purity specifications or requirements. **NOTE:** The optional **second** relay/alarm is "stacked" on the first relay/alarm, therefore, when setting the optional **second** relay/alarm Set Point, the #1 Set Point must be 'set' first.

1. While pressing the "SET POINT" switch, turn the Set Point #1 adjustment screw (see figure V.A.1) until the desired set point value is indicated on the display.

### HYSTERESIS (DEAD BAND) ADJUSTMENT -

See Section IV.C.4.

### PRIMARY COMPONENT IDENTIFICATION - Section V.A.

Review the figure below to familiarize yourself with the Main circuit board assembly. The diagram has the second alarm/control module option installed.

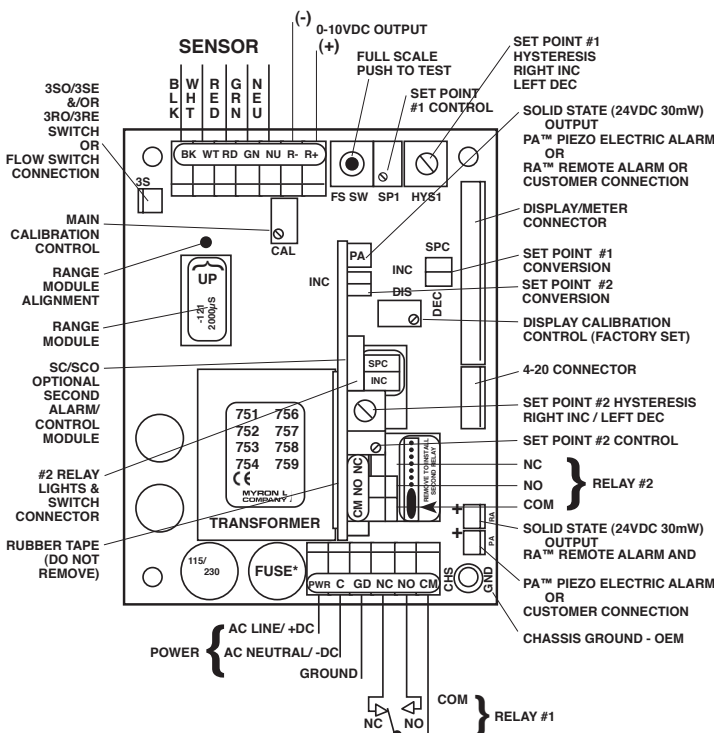


Figure V.A.1

### QUICK CALIBRATION - Section V.C.

**WARNING:** When performing calibration procedures, the technician must take extreme care to avoid contacting the circuitry other than the **CAL**ibration control. Failure to do so could result in damage to the equipment, property and/or personal injury.

The following assumes the front panel has been removed and the power is ON.

### ELECTRONIC CALIBRATION (CIRCUIT ONLY) - See Section V.C.1.

#### Full Scale Adjustment

1. Press and hold the Full Scale Test switch. The display should indicate Full Scale for the particular range selected, i.e. 0-500 ppm should indicate 500. If not, set to Full Scale with the **CAL**ibration control.
2. Turn power **OFF**.
3. Re-install front panel as described in "REASSEMBLY".
4. To operate, turn power **ON**.

#### 10VDC Calibration - See Section V.C.1.b.

#### Using Standard Solutions - Section V.C.2.

The **BEST** method of verifying and recalibrating your conductivity/TDS Monitor/controller is with NIST traceable Standard Solution (available from the Myron L Company). Because it includes the sensor, the entire system is recalibrated. **NOTE:** Since standard solution calibrations are NOT practicable with resistivity models, another means of verification or calibration of resistivity models is to use the transfer standard method, using a hand-held or portable instrument capable of resistivity measurements, i.e. the Myron L Ultrameter II™. See section V.C.4 for description.

The following procedure describes the easiest method for standard solution calibration of your Conductivity/TDS Monitor/controller.

1. Using a standard solution which is 60-90% of full scale of the instrument, rinse thoroughly and fill a clean glass beaker with the standard solution.
2. Place sensor in the beaker of standard solution. The level of standard solution must be high enough to cover at least 1/2" above cross hole.
3. Slowly shake the sensor to remove air bubbles from inside the sensor bore hole.
4. Allow 5-10 minutes for temperature to equilibrate. For the quickest and the best results, both the sensor and solution should be at the same temperature.
5. Turn power **ON**.
6. If the reading is different from the standard solution, adjust **CAL**ibration control on the main circuit board until the reading matches the solution value.
7. After adjustment, turn power **OFF**.
8. Re-install front panel as described in "REASSEMBLY".
9. To operate, turn power **ON**.

### SENSOR SUBSTITUTE CALIBRATION - See Section V.C.3.

### TRANSFER STANDARD METHOD - See Section V.C.4.



## 750 Series II

Model 758II -121-SC

(A Digital Conductivity  
Monitor/controller,  
with a Range of 0-2000  $\mu$ S,  
and a Second Alarm/control,  
Displaying Full Scale)

# TABLE OF CONTENTS

SECTION	PAGE
<b>750 Series II ILLUSTRATION (758II-121-SC)</b> . . . . .	<b>1</b>
<b>I. INTRODUCTION</b> . . . . .	<b>5</b>
A. SCOPE . . . . .	5
1. Functional Descriptions . . . . .	5
2. Applications . . . . .	5
B. SPECIFICATIONS . . . . .	5
C. OPTIONAL FEATURES . . . . .	6
D. ACCESSORIES . . . . .	6
E. SENSORS . . . . .	7
1. Conductivity/TDS . . . . .	7
2. Resistivity . . . . .	7
3. Sensor Specifications . . . . .	7
F. ORDER INFORMATION . . . . .	7
1. How to order Monitor/controller . . . . .	7
2. How to order Sensors . . . . .	7
G. RANGE SELECTION GUIDE . . . . .	8
<b>II. INSTALLATION</b> . . . . .	<b>9</b>
A. GENERAL . . . . .	9
B. MECHANICAL INSTALLATION . . . . .	9
1. Surface Mounting with SMP (surface mounting plate) Assembly . . . . .	9
2. Surface Mounting without SMP Assembly . . . . .	9
3. Panel Mounting . . . . .	9
C. OEM MECHANICAL INSTALLATION . . . . .	10
1. Circuit Board . . . . .	10
2. Analog Meter . . . . .	10
3. Digital Display . . . . .	10
D. SENSOR INSERTION / DIP MOUNT ASSEMBLIES . . . . .	11
1. Insertion Mode Assembly . . . . .	11
2. Alternate Dip Sensor Assembly . . . . .	11
E. ELECTRICAL INSTALLATION . . . . .	11
1. Main AC Power Installation . . . . .	11
2. 115/230 VAC Conversion . . . . .	12
3. Connecting the Sensor Cable . . . . .	12
a. Modification for US Pharmaceutical 25 (No Temperature Compensation) . . . . .	12
4. Solid State Output Connection . . . . .	13
a. Piezo Electric Alarm Installation (option) . . . . .	13
b. Remote Alarm Connection (RA option) . . . . .	13
c. Connect to your own alarm or ? . . . . .	14
5. Alarm/control Relay Connection . . . . .	14
6. Connecting Display Harness to Display . . . . .	14
F. 0-10 VDC OUTPUT . . . . .	15
1. Connection . . . . .	15
2. Voltage Divider . . . . .	15
G. RE-RANGE YOUR MONITOR/CONTROLLER (Range Module Installation) . . . . .	16
1. Description . . . . .	16
2. Installation . . . . .	16
3. Changing Analog Meter Scale (dial) . . . . .	17
4. Label Change . . . . .	18
<b>III. OPTIONS &amp; ACCESSORIES INSTALLATION</b> . . . . .	<b>19</b>
A. SC/SCO MODULE (SECOND ALARM/CONTROL OPTION) . . . . .	19
1. Description . . . . .	19

# TABLE OF CONTENTS Continued

SECTION	PAGE
2.	19
a.	20
b.	21
c.	22
d.	22
e.	22
B.	23
1.	23
2.	23
3.	24
4.	26
C.	27
1.	27
2.	27
3.	28
a.	29
b.	29
c.	30
4.	30
5.	32
6.	33
D.	34
1.	34
2.	34
E.	39
1.	39
2.	39
F.	40
1.	40
2.	40
3.	41
G.	43
1.	43
2.	43
3.	43
H.	45
1.	45
2.	45
3.	46
I.	48
1.	48
2.	48
J.	50
1.	50
2.	50
<b>IV.</b>	<b>52</b>
A.	52
1.	52
2.	52
3.	52
4.	52

# TABLE OF CONTENTS

SECTION	PAGE	
5.	Optional Front Panel Items . . . . .	.52
B.	OEM FRONT PANEL INDICATORS & CONTROLS . . . . .	.53
1.	Red "Set Point" LED Indicator . . . . .	.53
2.	Green "Set Point" LED Indicator. . . . .	.53
3.	"Set Point" Switch(es) . . . . .	.53
4.	Analog Meter or Digital Display . . . . .	.53
5.	Optional Panel Mounted Items . . . . .	.53
C.	SETUP PROCEDURES . . . . .	.54
1.	Set Point Conversion (SPC) or Reversing Set Point . . . . .	.54
2.	Check-Out Procedure . . . . .	.54
3.	Set Point Adjustment . . . . .	.54
4.	Hysteresis (Dead Band) Adjustment . . . . .	.54
V.	<b>COMPONENT IDENTIFICATION, CALIBRATION AND PREVENTIVE CARE . . . . .</b>	<b>.56</b>
A.	PRIMARY COMPONENT IDENTIFICATION . . . . .	.56
B.	METER MECHANICAL ZERO PROCEDURES . . . . .	.57
C.	CALIBRATION PROCEDURES - MAIN CIRCUIT BOARD . . . . .	.57
1.	Electronic Calibration (Circuit Only) . . . . .	.57
2.	Calibration Using Standard Solution . . . . .	.57
3.	Sensor Substitute Calibration . . . . .	.58
4.	Transfer Standard Method . . . . .	.59
D.	PREVENTIVE CARE . . . . .	.59
VI.	<b>OPTIONS &amp; ACCESSORIES . . . . .</b>	<b>.60</b>
A.	OPTIONS ORDERED WITH MONITOR/CONTROLLER. . . . .	.60
B.	OPTIONS & ACCESSORIES ORDERED SEPARATELY. . . . .	.60
C.	STANDARD SOLUTIONS & BUFFERS . . . . .	.61
VII.	<b>REPLACEMENT PARTS. . . . .</b>	<b>.62</b>
VIII.	<b>WARRANTY . . . . .</b>	<b>.64</b>
IX.	<b>GLOSSARY . . . . .</b>	<b>.65</b>
X.	<b>NOTES . . . . .</b>	<b>.66</b>
XI.	<b>ADDENDUM . . . . .</b>	<b>.67</b>
A.	CONDUCTIVITY, TDS AND TEMPERATURE RELATIONSHIPS . . . . .	.67



# I. INTRODUCTION

Thank you for selecting one of the Myron L Company's 750 Series II Monitor/controllers. The 750 Series II is based on input from 'you' - our customers, time proven designs, and many years of instrumentation experience.

Since 1957, the Myron L Company has been providing customers with quality products at an affordable price by designing and producing products that are Accurate, Reliable, Simple to use. Quality you have come to rely and depend on. As you read through this operation manual you will see the 750 Series II is truly designed to be user friendly with simple to install options, and easy re-rangeability as conditions or applications change. This manual is actually more complex than the 750 Series II Monitor/controller, but must be to address all the variables.

Where applicable the Original Equipment Manufacture (OEM) models are separated as necessary to clarify and define their differences. As defined by the Myron L Company, an OEM model does not have an enclosure. However, many OEMs use our enclosure just as if it were a standard model, therefore, as an end user you must decide whether to follow the OEM instructions or the "standard" models with enclosure. All OEMs mount the circuit board assemblies in differing locations making it impossible for us to describe exactly where to find them. By looking in section V. for the Main circuit board (CB) assembly, you will have a picture of what it looks like. If your OEM has a display, follow the display harness back to the Main CB. Once located you will be able to locate installed options by following the harnesses, i.e. 4A (4-20 mA output).

## A. SCOPE

This operation manual provides the user with the necessary information to install, operate and maintain the Myron L Company's 750 Series II Conductivity/TDS & Resistivity Monitors/controllers.

Section I. provides Descriptions, Applications, Specifications.

Section II. Installation; mounting, wiring and set up.

Section III. Options and Accessory installation procedures.

Section IV. Operating procedures.

Section V. Identifies their primary components and provides the user with easy-to-use calibration and preventive care procedures.

Section VI. Options & Accessories List.

Section VII. Replacement Components.

Section VIII. Warranty information.

Section IX. Glossary, definitions.

Section X. Notes.

Section XI. Addendum.

## 1. FUNCTIONAL DESCRIPTIONS

All models except OEMs have water & corrosion resistant IP64/ NEMA 3 housings suitable for panel, bench or surface mounting. The 750 Series II are a compact 6.0" (152mm) x 4.8" (122mm).

Bright green/red LEDs indicate HIGH/LOW set point readings. All models except 751II, 754II, 756II, & 759II, (see below) feature a heavy-duty 10 amp output relay, operating on either increasing or decreasing readings.

For specific Monitor/controller configurations, reference the following individual model descriptions.

## Models 757II Conductivity/TDS & 752II Resistivity

Analog Monitor/controller. Standard front panel is equipped with a linear analog meter display and a "SET POINT" switch with High/Low indicator lights. Single set point is internal to discourage unauthorized adjustments. A second set point alarm/control is available as an option. 4-20mA output option is available on OEM models only.

## Models 758II Conductivity/TDS & 753II Resistivity

Digital Monitor/controller. Standard front panel is equipped with a 3 1/2 digit liquid crystal display (LCD), and a "SET POINT" switch with High/Low LED indicator lights. Single set point is internal to discourage unauthorized adjustments. A second set point alarm/control is available as an option. May use an optional 4-20mA output for PLC or SCADA operations.

## Models 756II Conductivity/TDS & 751II Resistivity

Analog monitor ONLY. Standard front panel is equipped with a linear analog meter, no relay, LED indicators or set point switch. A 4-20mA output option is available on OEM models only.

## Models 759II Conductivity/TDS & 754II Resistivity

Digital monitor ONLY. Standard front panel is equipped with a 3 1/2 digit liquid crystal display (LCD) only, no relay, LED indicators or set point switch. May use an optional 4-20mA output for PLC or SCADA operations.

## 2. APPLICATIONS

### Conductivity/TDS

Reverse Osmosis  
Process Control  
Seawater Desalination  
Wastewater Treatment  
Food Processing  
Plating  
Power Plants  
Laboratories  
Printing  
Boiler  
Cooling Tower  
Agriculture/Aquaculture

Are just a few of the applications

### Resistivity

Deionization (DI) and Distillation Ultrapure Water  
Treatment Systems  
Electronics  
Pharmaceutical  
Laboratories  
Food Processing  
Plating  
Power Plants

Are just a few of the applications

## B. SPECIFICATIONS

RANGES: 34 Conductivity/TDS ranges from  
0-1  $\mu$ S/ $\mu$ M/ppm to 0-200mS/mM/ppt  
7 Resistivity ranges from 0-200K $\Omega$  to 0-20M $\Omega$ .  
Refer to Range Selection Guide on Page 8.

### DISPLAY:

Models 756II, 757II & 751II, 752II:  
2 1/2" (63mm) analog meter  
Models 758II, 759II & 753II, 754II:  
13mm/ 1/2" 3 1/2 digit LCD

**NOTE:** 3 1/2 digit LCD may be replaced with either a 3 1/2 or a 4 1/2 digit backlit LCD - available as options.

#### ACCURACY

Analog Models: + 2% of Full Scale  
Digital Models: + 1 % of Full Scale

#### SENSITIVITY

0.05% of span

#### STABILITY

0.05% of span

#### REPEATABILITY

0.1% of span

#### CALIBRATION CHECK

Built in full scale value

#### RECORDER OUTPUT

0-10 VDC @ 5mA max. (linear); standard on all models

#### OUTPUT IMPEDANCE

100Ω ±5%

#### SENSOR INPUT 1 (optional 3 sensor input available)

#### CONTROL FUNCTION

Models 757II, 758II & 752II, 753II:

Single set point alarm/control continuously adjustable  
0-100% of span

Second set point alarm/control (Optional).

Continuously adjustable - 0-100% of span

#### Hysteresis

Adjustable from 0.3-3% of full scale

#### Indicators

"HIGH" (red) and "LOW" (green) set point LEDs - reversible.

#### Relay Contact Rating

SPDT 10 amp @ 250 VAC, 30 VDC. Relay operates  
increasing or decreasing reading (user selectable).

#### Solid State Output

24VDC unregulated, 30mA Maximum.

Powers optional PA - Piezo Electric Alarm, RA™ - Remote  
Alarm, or ?

Second Alarm/control Module, with above specifications, opt. on  
Models 757II, 758II & 752II, 753II

#### POWER SPECIFICATIONS

**115/230 VAC** ±15%, 50/60 Hz (User selectable)  
overvoltage category II

100 mA Maximum Current

Double Insulated (with circuit board ground for OEM  
operation)

Fuse - 100mA Slow Blow (T.10A) for both 115 & 230 VAC  
(V~) User replaceable

Humidity - 20-90% non-condensing

Max. Altitude -

12,000 meters/40,000 ft non-operating

3000 meters/10,000 ft operating

Pollution degree 2

**24 VAC or 24 VDC** Option available on Special Order

Overvoltage category II (24 VAC)

250 mA Maximum Current

Double Insulated (with circuit board ground for OEM  
operation)

Fuse - 250mA Slow Blow (T.25A) User replaceable

#### AMBIENT TEMPERATURE RANGE

0-60°C/32-140°F

#### DIMENSIONS

152H x 122W x 96 D mm / 6.0 H x 4.8 W x 3.8 D in.

#### HOUSING CONSTRUCTION

Fully gasketed heavy-duty ABS for splash-proof and corrosion  
resistance.

Rated IP65/NEMA 4X

Double Insulated (with circuit board ground for OEM operation)



### DOUBLE INSULATED

#### WEIGHT

750 Series II: average 0.9 kg/2 lbs.

#### C. OPTIONAL FEATURES

See sections VI & VII for complete selection and details.

-SC	Second Alarm/control Module (M/c only)
-4A	4-20 mA Isolated output (digital models only)
-PA	70 db Piezo Electric Alarm (digital M/c only)
-PAT	Piezo Alarm & Timer Module (digital M/c only)
-45BL	4 1/2 Digit Backlit Liquid Crystal Display (LCD)
-35BL	3 1/2 Digit Backlit Liquid Crystal Display (LCD)
-TP	Temperature Module 0-200°C, requires -TP sensor (digital Monitor/controllers only)
-TH	Alarm/control Interface Harness (req. SC & TP) (digital only)
-PC	115 VAC Power cord (8 ft./2,44 meters) with USA plug and strain relief - <b>NOT</b> for use with 230 VAC.
-24VA	24 VAC Isolated Power Supply (special order)
-24VD	24 VDC Isolated Power Supply (special order)
-PTS	Panel mounted Full Scale Test switch (special order)

#### D. ACCESSORIES (ordered separately)

See sections VI & VII for complete selection and details.

ASI	AQUASWITCH I, auto RO/DI switching system (req. M/c)
SCO	Second Alarm/control Module (Monitor/controllers only)
4AO	4-20 mA Self-Powered Isolated Output Module (digital only)
3SE	3 Sensor Input Module with Enclosure.
3SO	3 Sensor Input Module with 1 meter/3 foot cable*.
3RE	3 Range Switch with Enclosure†
3RO	3 Range Switch with 1 meter/3 foot cable†.
3SRO	Above 3SO & 3RO combined with enclosure†.
3SRE	Above 3SO & 3RO combined†*.
PAO	70 db Piezo Electric Alarm only (753II/758II)
PATO	Piezo Alarm & Timer Module (753II/758II)
45BLO	4 1/2 Digit Backlit Liquid Crystal Display (LCD)
35BLO	3 1/2 Digit Backlit Liquid Crystal Display (LCD)
TPO	Temperature Module 0-200°C - requires -TP sensor (digital models only)
THO	TP/TPO Alarm/control Harness only (requires SCO & TPO)
PCO	Power Cord 115 VAC (8 ft./2,44 meters) with USA plug and strain relief - <b>NOT</b> for use with 230 VAC.
SMP50	Surface Mounting Plate
RA	Remote Alarm™ - RA (Monitor/controllers only)
VR	Power Supply, 24 VAC, 20VA. (115VAC, indoor use)
024-1	1 in. NPT 24 VAC Solenoid Valve
CS-11	20Ω Resistivity Calibration Module (NIST Traceable)
CS-14	2Ω Resistivity Calibration Module (NIST Traceable)
CS-17	200Ω Resistivity Calibration Module (NIST Traceable)

†Add **C** for Conductivity or **R** for Resistivity to part number

\*Customer mounted separately

## E. SENSORS

### 1. CONDUCTIVITY/TDS

750 Series II Conductivity/TDS Monitor/controllers use the CS51LC, CS51 or CS52 Series sensor depending on range. The 1.0 cell constant CS51 model is recommended for ranges of 0-10 through 20,000  $\mu\text{S}/\text{ppm}$ . Its compact size allows mounting in a standard 3/4" tee. The sturdy polypropylene bushing is modular for easy, inexpensive replacement. Other models available by special order.

CS52 sensors have a 10.0 cell constant and are used for conductivity/TDS values above 20,000  $\mu\text{S}/\text{ppm}$ .

CS51LC sensor has a cell constant of 0.1 and is used for conductivity/TDS values of 0-1 to 0-5  $\mu\text{S}/\text{ppm}$ .

Special order High Temperature, High Pressure sensors; and Low Cost, Low Temperature, Low Pressure sensors are available. For detailed descriptions of these and other sensors, see Sensor Selection Guide and specific sensor data sheets available from your local distributor, the Myron L Company, or on line at [www.myronl.com](http://www.myronl.com).

### 2. RESISTIVITY

750 Series II Resistivity Monitor/controllers use the CS10 sensor. It has a cell constant of 0.05 and is used for ultra pure water applications. Other models available by special order.

### 3. SENSOR SPECIFICATIONS

*See sensors price list for complete selection and details.*

STANDARD MODELS	—	316 Stainless Steel	CONSTANT
CS51LC:	For ranges 0-5 $\mu\text{S}/\text{ppm}$ & below		0.1
CS51:	For ranges between 0-10 & 0- 20,000 $\mu\text{S}/\text{ppm}$		1.0
CS52:	For ranges above 20,000 $\mu\text{S}/\text{ppm}$		10.0
CS10:	For ALL Resistivity ranges		0.05

See Range Selection Guide, Page 8.

### SPECIAL ORDER MODELS — 316 Stainless Steel

CS40	Conductivity/TDS Valve Insertable 100psi@120°C (10.0, 1.0, 0.1 & 0.05)
CS40HT	Above High Temp Model (Temporarily unavailable; contact manufacturer)
CS41	Cond/TDS High Temp Model 100psi@150°C
CS41HT	Cond/TDS High Temp Model 250psi@205°C
CS50	Conductivity/TDS 100psi@95°C (1.0 & 0.1)
CSA	Low Cost Conductivity/TDS - NO Temperature Compensation 75psi@60°C (1.0)
CSATC	Low Cost Conductivity/TDS - with Temperature Compensation 75psi@60°C (1.0)

### 4. SENSOR OPTIONS

-T	Titanium - in place of Stainless Steel
-TP	Temperature Sensor 0-200°C (special order)
-WTV	Wet-Tap Valve for CS40 (0.1 & 1.0 only)
-JB	Junction Box - Class I, Group D, Div. S, explosion and weather proof aluminum. For CS40/CS40HT.
-STF	Sanitec Fitting for CS10, CS51 & CS51LC. 1/2" thru 4". State size, i.e. STF1/2.
-25	25' Shielded Cable (Standard 5 wire sensor)*
-100	100' Shielded Cable (Standard 5 wire sensor)*
-PV	1/2" PVDF fitting for CS10 & CS51 ONLY (replaces polypropylene)
-HPSS	1/2" 316 STAINLESS STEEL fitting for CS10 & CS51 ONLY (replaces

polypropylene).

\* -TP Sensor 8 wire cable, contact the Myron L Company

### TEMPERATURE COMPENSATION

Automatic to 25°C, between 0-100°C/32-212°F except high temperature models - up to 205°C.

### PRESSURE/TEMPERATURE LIMITS

CS10 & CS51 - 689.6 kPa/100 psi at 100°C/212°F  
For higher limits, see specifications below.

### BUSHING

CS51 (LC): Modular Polypropylene threaded 3/4" NPT  
CS52: 316 stainless steel 3/4" NPT internal to cell body  
CS10: Modular Polypropylene threaded 3/4" NPT

### CABLE

Shielded; 10ft./3 meters standard  
25ft./7 meters and 100ft./30 meters lengths also available

### DIMENSIONS

CS51(LC): Metal portion 30mm/1.2 in. L;  
13mm/0.5 in. DIA

CS10: Metal portion 30mm/1.2 in. L; 13mm/0.5 in. DIA

For other models see sensor selection & specific data sheets for details.

## F. ORDERING INFORMATION

### 1. HOW TO ORDER MONITOR/CONTROLLERS

#### EXAMPLE:

MODEL	RANGE	OPTIONS
758II	— 121	— SC - 4A - PA

Written as — 758II-121-SC-4A-PA

This is a Digital Monitor/controller with a 0-2000  $\mu\text{S}$  range, a Second Alarm/control, a 4-20 mA output and a Piezo Electric Alarm.

**NOTE:** Monitor model number does not include sensor. Please specify sensor required when ordering.

#### RANGE SUFFIXES:

See RANGE SELECTION GUIDE, Page 8.

### 2. HOW TO ORDER SENSORS

Add option to model number as in examples below.

#### EXAMPLE:

MODEL	OPTIONS
CS51	— T-TP-100

Written as — CS51-T-TP-100

The above is a model CS51 sensor made with Titanium, with the Temperature sensor, and a 100 foot cable.

#### EXAMPLE:

MODEL	OPTIONS
CS41HT	— 01-T-WTV-TP

Written as — CS41-01-T-WTV-TP

The above is a Special Order High Temperature sensor with a cell constant of 0.1, made of Titanium, a Wet-Tap Valve and a Temperature sensor.

# G. 750 SERIES II RANGE SELECTION GUIDE CONDUCTIVITY/TDS & RESISTIVITY

Add Range NUMBER below to instrument model number, i.e. 758II-"112" = 0-50 ppm Digital Monitor/controller.

756II, 757II, 758II & 759II

751II, 752II, 753II & 754II

RANGE	CONDUCTIVITY/TDS Dash #	RESISTIVITY Dash #
<b>Resistivity</b>		
0-20 MΩ		-11
0-10 MΩ†		-12
0-5 MΩ†		-13
0-2 MΩ		-14
0-1 MΩ†		-15
0-500 KΩ†		-16
0-200 KΩ		-17
<b>Conductivity</b>		
0-1 μS*†	-101	
0-1 ppm*†	-102	
0-2 μS*†	-103	
0-2 ppm*†	-104	
0-5 μS*†	-105	
0-5 ppm*†	-106	
0-10 μS†	-107	
0-10 ppm†	-108	
0-20 μS	-109	
0-20 ppm	-110	
0-50 μS	-111	
0-50 ppm	-112	
0-100 μS	-113	
0-100 ppm	-114	
0-200 μS	-115	
0-200 ppm	-116	
0-500 μS	-117	
0-500 ppm	-118	
0-1000 μS	-119	
0-1000 ppm	-120	
0-2000 μS	-121	
0-2000 ppm	-122	
0-5000 μS††	-123	
0-5000 ppm††	-124	
0-10,000 μS/0-10 mS††	-125	
0-10,000 ppm/0-10 ppt††	-126	
0-20,000 μS/0-20 mS††	-127	
0-20,000 ppm/0-20 ppt††	-128	
0-50,000 μS/0-50 mS**††	-129	
0-50,000 ppm/0-50 ppm**††	-130	
0-100 mS**††	-131	
0-100 ppt**††	-132	
0-200 mS**††	-133	
0-200 ppt**††	-134	

\*CS51LC conductivity sensor (0.1 constant) required for these ranges.

\*\*CS52 conductivity sensor (10.0 constant) required for these ranges.

† Available in Digital models only.

†† Available with 4 1/2 Digit Backlit LCD. Other ranges available as OEM ONLY. Price & delivery on request.

Except as noted, Conductivity/TDS Monitor/controllers require a sensor with a cell constant of 1.0. The Model CS51 is the most commonly selected sensor due to its ease of use and low cost.

Resistivity Monitor/controllers require a sensor with a cell constant of 0.05. The Model CS10 is the most common selected due to its ease of use and low cost.

**NOTE:** UNLESS ppm/NaCl is specified with order, TDS/ppm type conductivity instruments will be calibrated to the Myron L "442™" Natural Water standard. For NaCl ppm/ppt add the letter "N" after the number, i.e. -124N.

# II. INSTALLATION

## A. GENERAL

This section provides the recommended procedures for properly installing the 750 Series II Conductivity/Resistivity Monitor/controller, and sensors. For OEM models see section C.



### CAUTION - READ FOLLOWING CAREFULLY

**WARNING: THE MYRON L COMPANY RECOMMENDS THAT ALL MOUNTING AND ELECTRICAL INSTALLATIONS BE PERFORMED BY QUALIFIED PERSONNEL ONLY. FAILURE TO DO SO COULD CAUSE DAMAGE TO INSTRUMENT, AND COULD BE HARMFUL OR FATAL TO PERSONNEL.**

## B. MECHANICAL INSTALLATION

All Monitor electronics are packaged inside drip/weather-proof housings. The physical dimensions of the housing is suitable for panel, bench or surface mounting.

There are four basic guidelines to consider when selecting a Monitor's mounting location:

1. Select a site that limits the Monitor's exposure to excessive moisture and corrosive fumes.
2. For best results, position your Monitor/controller and sensor as close as possible to the point(s) being controlled. The 750 Series II Conductivity/TDS & Resistivity Monitor/controllers are not designed to operate with a Sensor cable length that exceeds 100 ft./30 meters.
3. If at all possible, mount the Monitor at eye level for viewing convenience.
4. If needed, the enclosure may be rotated or mounted upside down so that the cutouts are on the opposite side.

### 1. SURFACE MOUNTING WITH SMP

**NOTE:** A Surface Mounting Plate (SMP50) may be required when access to the back side of the mounting site is impractical or if the Monitor/controller must be mounted on a solid wall. The

SMP50 comes with the proper hardware to mount the Monitor/controller to the SMP, however, the installer must provide the four (4) additional screws/bolts to mount the SMP to the wall or fixture. Their size is to be determined by the user.

1. Select your mounting location. Mark and drill the four (4) required mounting holes. For hole locations, use the SMP as a template.
2. Drill the corner holes in the SMP according to the size of the screws or bolts selected.
3. Attach and securely fasten the SMP to the Monitor using the 1/4" X 20 X 3/8" screws provided.
4. Mount the SMP to the prepared site using the selected screws or bolts.

### 2. SURFACE MOUNTING WITHOUT SMP

**NOTE:** Surface mounting will require two (2) 1/4" X 20 screws of a length equal to the thickness of the mounting site plus 3/8"

1. Select mounting site location. Mark and drill the required mounting holes. For hole drilling locations, see figure II.B.1.
2. Insert the 1/4" X 20 screws into the holes from the side opposite the mounting site.
3. Hold the Monitor in place while starting and tightening the mounting screws.

### 3. PANEL MOUNTING

A panel mounting fastening kit is provided with all Monitor/controllers. Panel mounting will require the use of the fastening kit's two (2) 4-40 mounting screws/nuts or two (2) #4 x 1/2" sheet metal screws. See figure II.B.1. for panel cutout dimensions.

1. Select your mounting location. Mark the appropriate panel cutout and complete the necessary panel cut.
2. Carefully unfasten and separate the Monitor's front panel from its enclosure.
3. Disconnect all panel cable(s)/wire(s) from the Monitor's Control board.

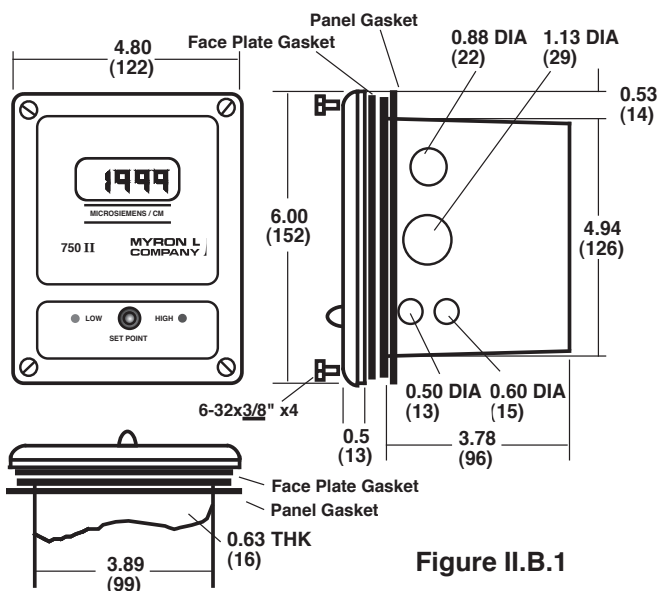
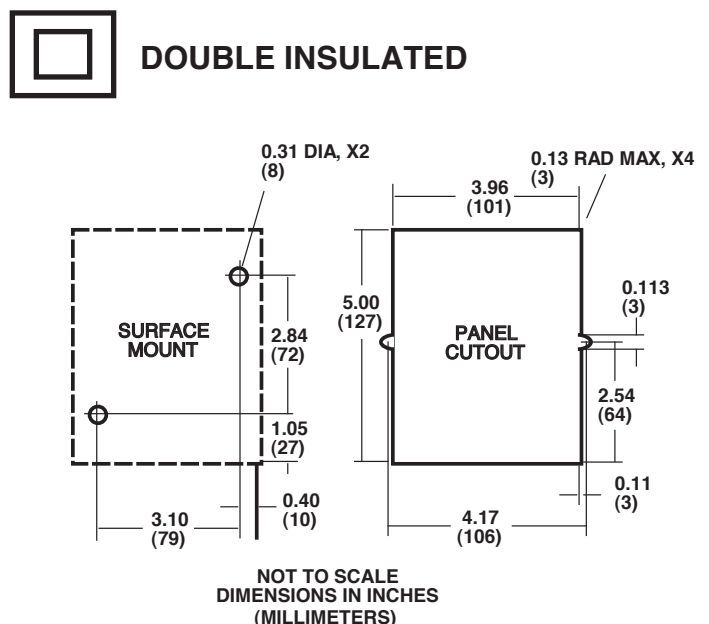


Figure II.B.1



SURFACE AND PANEL MOUNTING DIAGRAMS

4. Slide the enclosure through the panel cutout until its flange contacts the panel.
5. Insert mounting screws through the flange mounting holes and tightly secure.
6. Reconnect all panel cable(s)/wire(s) and re-secure the front panel using 6-32 x  $\frac{3}{8}$ " screws provided.

**Caution:** Do not use 6-32 x  $\frac{1}{2}$ " used on "picture frame" front panel models.

### C. OEM MECHANICAL INSTALLATION

This section provides the recommended procedures for properly installing the OEM 750 Series II Conductivity/Resistivity Monitor/controller.

**NOTE:** Mounting of the OEM monitor/controller circuit board is left up to the OEM. It is recommended that the following be noted and observed.

#### 1. CIRCUIT BOARD

Total height of CB is 1.40" (36mm).

The circuit board has four (4) .175" (4.4 mm) holes for mounting. The centers are 3.10" (78.7 mm) x 4.10" (104.1 mm) see figure II.C.1. CB must be mounted on at least .250" (6.35 mm) standoffs to prevent shorting to metal chassis (standoffs user supplied). CB must be mounted in a clean and dry environment. Allow working room for inserting wires, testing and calibration. Indicator lights and switches require  $\frac{1}{4}$ " (6.35mm) holes.

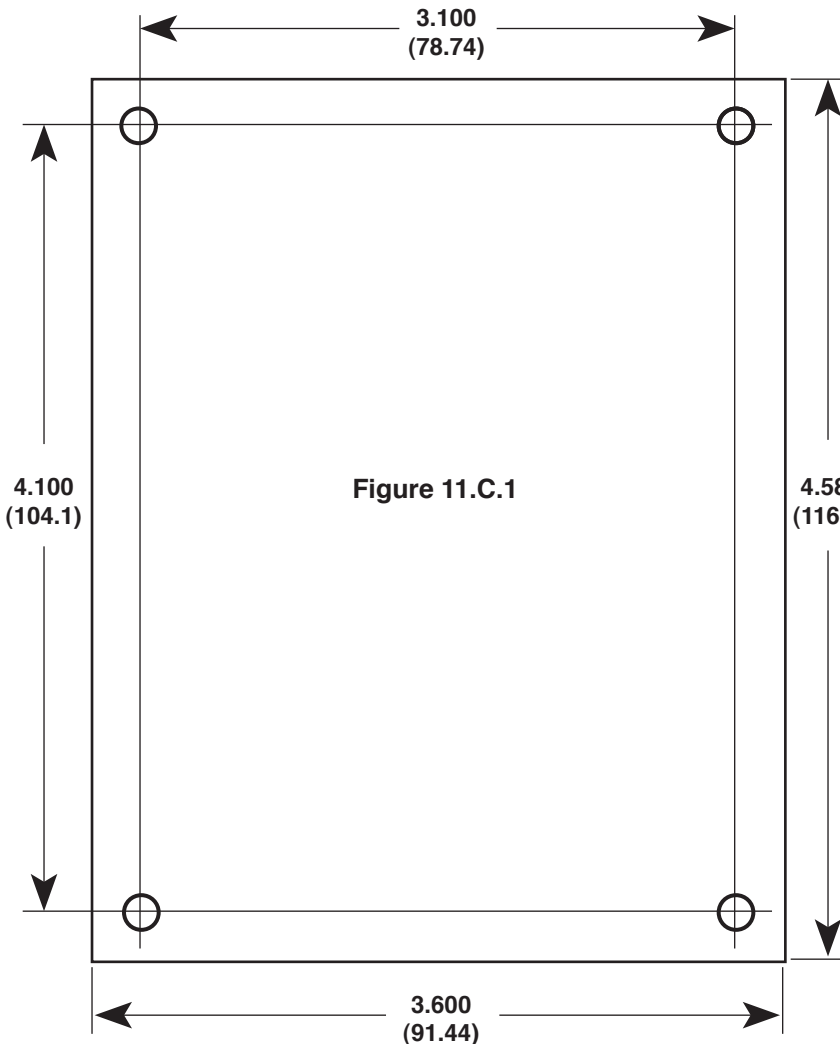
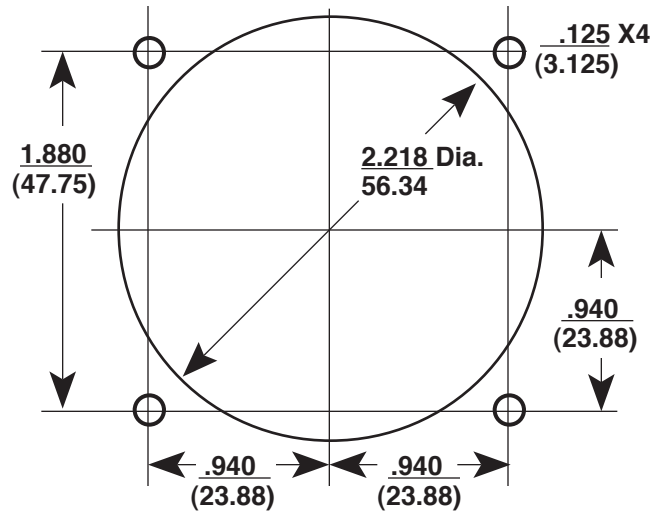


Figure 11.C.1

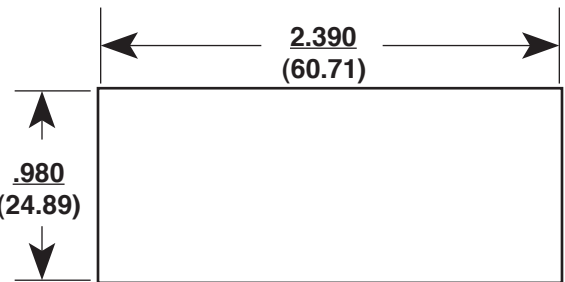


Analog Meter Hole Pattern  
Figure II.C.2

#### 2. METER MOVEMENT

Refer to figure II.C.2 for dimensions.

1. Cut opening in user panel.
2. Drill four (4) holes at locations as shown.
3. Install meter movement using supplied hardware.



DIGITAL DISPLAY CUTOUT  
PATTERN  
Figure II.C.3

#### 3. DIGITAL DISPLAY

Refer to figure II.C.3 for dimensions.

1. Cut opening in user panel.
2. Install LCD with brackets supplied.

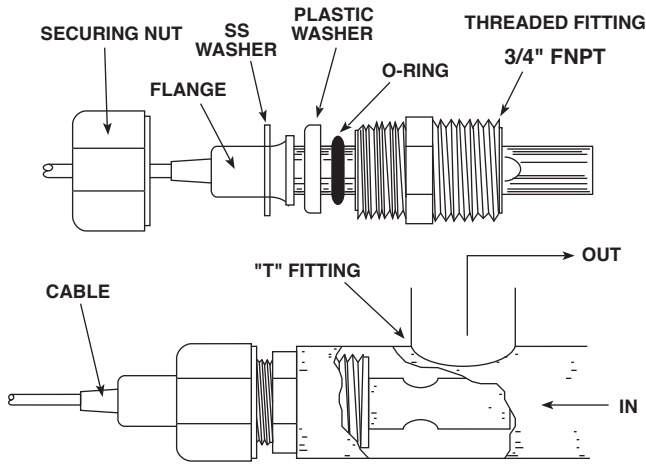
**D. SENSOR INSERTION/IMMERSION MOUNTING**

The Sensor's mounting orientation must provide a continuous and adequate circulation flow to prevent the trapping of air bubbles within the Sensor's electrode area (CS51 shown in figure II.D.1). Failure to do so will result in conditions that will prevent the Sensor from functioning properly.

**1. INSERTION MODE (in-line installation)**

Use approved sealant, i.e. Teflon tape as required.

1. Verify that the Sensor's Fitting assembly is properly assembled as shown in figure II.D.1.
2. Insert the Sensor Fitting assembly into the "T" fitting with electrode aligned as shown in figure II.D.1. and tightly secure.

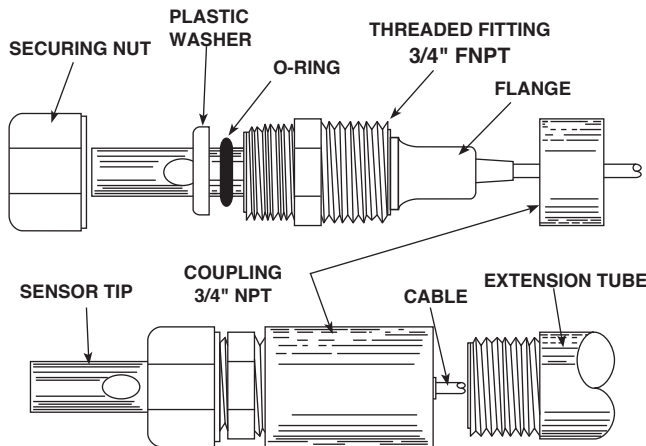


**INSERTION MODE ASSEMBLY**  
Figure II.D.1

**2. IMMERSION OR DIP SENSOR ASSEMBLY**

Use approved sealant, i.e. Teflon tape as required.

1. Verify that the Sensor's Fitting assembly is properly assembled as shown in figure II.D.2.
2. Insert and pull the Sensor's cable through the extension tube and then tightly attach extension tube to Sensor assembly as shown in figure II.D.2.



**IMMERSION OR DIP SENSOR ASSEMBLY**  
Figure II.D.2

**E. ELECTRICAL INSTALLATION**

The electrical installation procedures provided in this manual are common to all Conductivity & Resistivity Monitor/controllers. See figure II.B.1. for the hole dimensions of the enclosure's cable access holes. Unless otherwise instructed, refer to figure II.E.1. for the 750 Series II Monitor's terminal block connector wiring designations.

**NOTE:** After removing an enclosure's access hole cutout, it is suggested that the user mount a watertight restraint fixture prior to installing a cable.



**WARNING!**

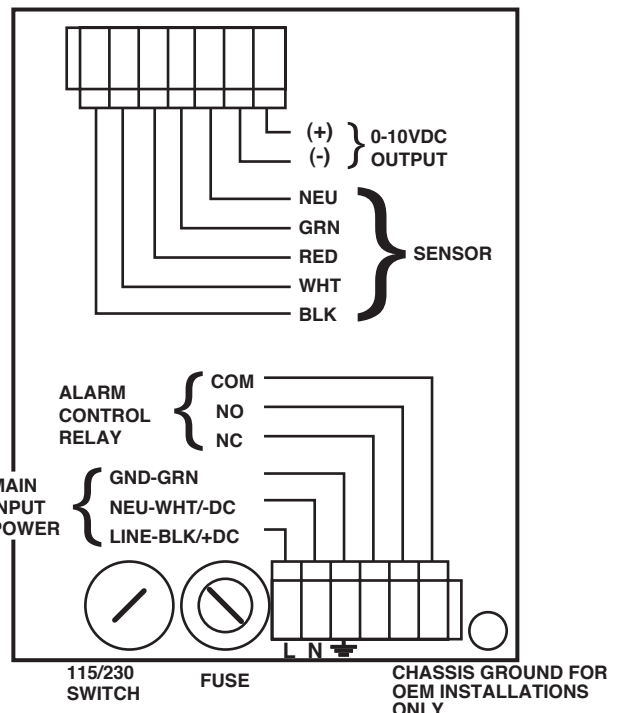
A device to disconnect the Model 750II from the power supply is required. It is recommended that this switch or circuit breaker be labeled as the disconnection device for the Model 750II.

**1. MAIN INPUT POWER INSTALLATION**

**WARNING:** All AC line powered Monitor/controllers are factory set for 115 VAC. Before starting, ensure the input power "115/230" selection is correct for your requirements. Failure to do so is beyond the responsibility of the Myron L Company. See section II.E.2. below and figure II.E.1. **NOTE:** Some models may have either a 24 VAC or a 24 VDC input power requirement - check labels carefully.

For OEM models skip to step #7.

1. Verify that the main AC power source is turned "OFF" or disconnected.
2. Using a standard slot screwdriver remove the four (4) screws on the front panel.
3. Carefully wiggle the front panel to loosen and pull gently toward you. Do not pull more than about 8 inches/20CM or you could damage the wiring harness.



**ELECTRICAL CONNECT DIAGRAM**  
Figure II.E.1

4. Turn the front panel around so that the back side is facing you and set aside for now.
5. Carefully remove front panel, leaving the harness connected.
6. Using the enclosure cutouts, install the proper wire and watertight cable restraint (not provided) to comply with local electrical codes.
7. Neatly connect wires to the Main Circuit Board connectors, as shown in figure II.E.1.

**\*CAUTION:** The input power connectors require only a small screwdriver or a pen to push on the release levers. The release levers may be broken or damaged if not pushed straight toward the circuit board. DO NOT push the release levers sideways.

## 2. 115/230 VAC CONVERSION

1. Before turning power on to the Monitor/controller ensure the proper input voltage has been selected. Failure to do so will blow the fuse. It could, under some conditions, cause injury and damage the instrument voiding the warranty.
2. Locate switch located next to the fuse holder.
3. Using a screwdriver, turn switch to required voltage.

## 3. CONNECTING THE SENSOR CABLE

For OEM models skip #1.

1. Place the Sensor's interface cable and user supplied watertight cable restraint into the enclosure's appropriate access hole.
2. Install the sensor cable wire to comply with local electrical codes. Follow the color code as marked. See figure II.E.1.

**\*CAUTION:** The sensor connectors require only a small screwdriver or a pen to push on the release levers. The release levers may be broken or damaged if not pushed straight toward the circuit board. DO NOT push the release levers sideways.

### a. MODIFICATION FOR US PHARMACEUTICAL 25 (No Temperature Compensation)

This simple modification will allow your Monitor/controller to meet the USP 25 requirements by defeating the normal temperature compensation circuit thus giving "uncompensated" readings as required.

#### Specifications:

As required to meet USP25.

#### Installation

Briefly -

For Conductivity/TDS, a resistor is installed in place of the sensor "temperature" sensing leads.

For Resistivity, two resistors are installed in place of the sensor "temperature" sensing leads.

The extra sensor leads are either cut off or the ends are wrapped in tape to prevent shorting.



## CAUTION - READ FOLLOWING CAREFULLY

**WARNING: BEFORE STARTING, IF MONITOR/CONTROLLER IS INSTALLED, ENSURE THE POWER IS OFF. FAILURE TO DO SO COULD CAUSE DAMAGE TO THE INSTRUMENT, AND COULD BE HARMFUL OR FATAL TO PERSONNEL. ONLY QUALIFIED PERSONNEL SHOULD INSTALL OR SERVICE ELECTRICAL EQUIPMENT.**

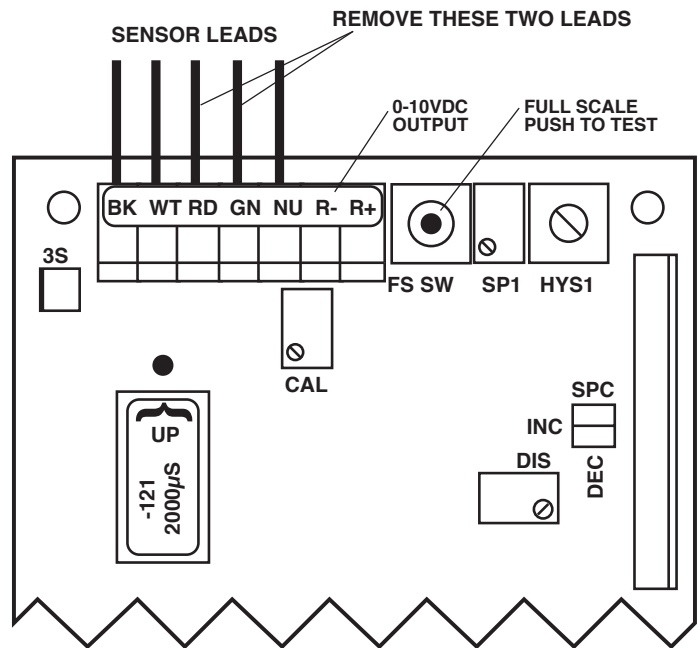
#### Requirements:

For Conductivity/TDS; one 10kW 1% resistor, user supplied or may be ordered from the Myron L Company.

For Resistivity; one 100kW 1% resistor, and one 5.49KW 1% resistor, user supplied or may be ordered from the Myron L Company.

**NOTE:** When opening instrument, remove front cover with care; a ribbon cable connects the front panel and main board. If the front panel has all ready been removed from the enclosure skip to #4.

1. Using a standard slot screwdriver remove the four (4) screws on the front panel.
2. Carefully wiggle the front panel to loosen and pull gently toward you. Do not pull more than about 8 inches/20CM or you could damage the wiring harness.
3. Turn the front panel around so that the back side is facing you and set aside.
4. For Conductivity/TDS Monitor/controllers;
  - a. If sensor is installed, locate and remove the RED (RD) and the GREEN (GN) leads from MAIN Circuit Board, as shown in figure II.E.2.



**Conductivity/TDS Main CB Assembly  
Figure II.E.2**

- b. Cut off or tape RED (RD) and the GREEN (GN) leads from sensor.
- c. Install 10kW resistor at RED (RD) and the GREEN (GN) connector locations, as shown in figure II.E.3.

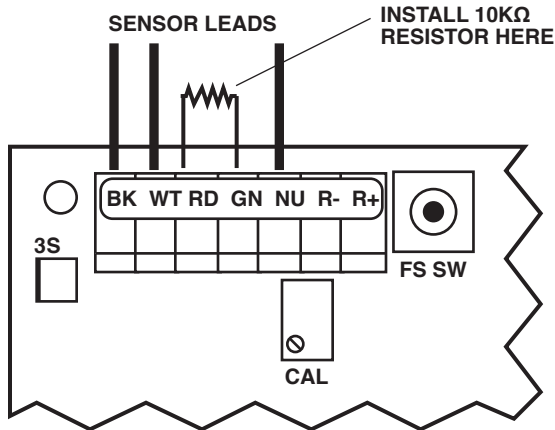
For Resistivity Monitor/controllers;

- a. If sensor is installed, locate and remove the GREEN (GN), RED (RD), and the NEUTRAL (NU) leads from MAIN Circuit Board, as shown in figure II.E.4.
- b. Cut off or tape GREEN (GN), RED (RD), and the NEUTRAL (NU) leads from sensor.
- c. Install 100kW resistor at BLACK (BK) and GREEN (GN) connector locations, as shown in figure II.E.5.

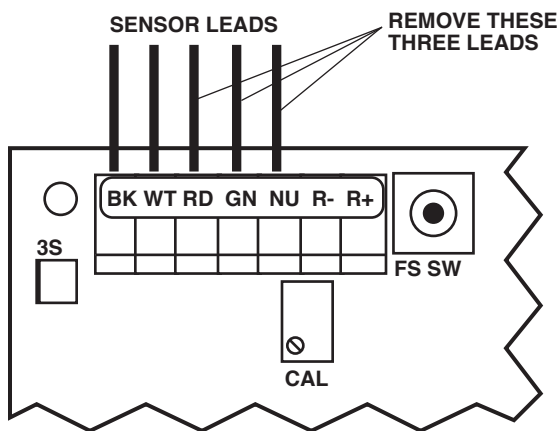


- d. Install 5.49kΩ resistor at RED (RD) and the NEUTRAL (NU) connector locations, as shown in figure II.E.5.
5. Carefully reinstall the front panel, bottom first. Ensure no wires have been pinched between enclosure and front panel.
6. Reinstall the four (4) screws and tighten.
7. To operate, turn power **ON**.

**NOTE:** Recalibration will require both the solution and sensor be at 25°C for maximum accuracy.



**Conductivity/TDS Main CB Assembly**  
Figure II.E.3



**Resistivity Main CB Assembly**  
Figure II.E.4

#### 4. SOLID STATE OUTPUT

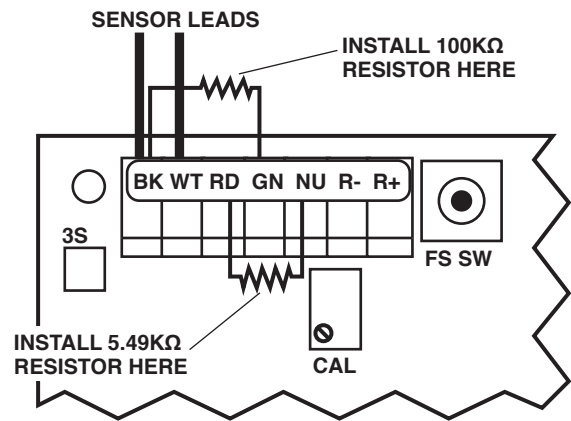
24 VDC Unregulated 30mA max. The following instructions are assuming the Monitor/controller enclosure is already open.

##### a. Piezo Electric Alarm - PA/PAO (option)

For additional information, see Piezo Alarm under Options in section III.I.

1. If not already installed, peel tape backing from PIEZO and press into place per figure III.I.3.
2. Attach connector to main control circuit board per figure III.I.4.

**NOTE:** If remotely mounted; cut wires and splice as necessary, use comparable wire. Piezo requires 1/4" (6.35mm) hole in user panel.



**Resistivity Main CB Assembly**  
Figure II.E.5

##### b. Remote Alarm - RA™ (option)

For additional information, see RA Instructions under options in section III.J.

1. Run user supplied #22, 2 conductor speaker type wire from Monitor/controller to RA location as necessary. Additional wire may be ordered, part #RAW-200, see Options & Accessories.
2. Open the RA by removing the four (4) screws.
3. Locate and remove the 8" 2 conductor wire attached to RA.
4. At the controller, connect the extension wires to the 8" 2 conductor wire with the wire nuts provided — Black to Positive (+) and White to Negative (-). Be sure to first pass the wire through the user supplied waterproof strain relief in the enclosure.
5. Plug the reddish brown female connector into the male connector on the controller CB marked either RA or PA (see inside case label for location). It will only go on the connector one way.
6. At the RA, connect the wires to the connector — Black to Positive (+) and White to Negative (-).
7. To test, simply turn on the controller and adjust controller set point until the alarm/piezo sounds off. If controller is not yet connected to a functioning sensor, on conductivity/TDS controllers it will be necessary to press and hold the Full Scale test switch. The black button on the front of the RA will mute the piezo alarm for approximately three minutes or until you improve the water quality (readjust controller set point). The piezo alarm will continue to sound off every three minutes until the user has improved the alarm condition inside the controller. If three minutes muting is fine for your application, skip to step 9.
8. If three minutes is too long or too short, adjust time delay control inside RA until desired mute time is achieved (adjustable from approximately 6 seconds to 10 minutes).
9. Replace the bottom of the RA, and secure RA to the surface you have selected for its installation.

**NOTE:** If the RA does not sound off;

1. Check the polarity of the extension wire connections.
2. Be sure the controller is actually switching (relay will click).

**c. Connect to your own alarm or ?**

Use the following as guidelines.

Connector is a standard 2 wire Methode\* style connector. Connector with 8" wires, part #RAH, is available from the Myron L Company.

Ensure your requirements do not exceed the 24VDC Unregulated 30mA maximum.

Ensure the polarity is correct (RED is positive), see figure V.A.1.

Attach wires to RA.

Attach connector to controller connector (RA) per figure V.A.1.

\*Methode is registered trademark of Methode Electronics, Inc.

**5. ALARM/CONTROL RELAY CONNECTIONS**

Myron L Company Monitor/controllers are equipped with a "Dry Contact" relay which is designed to energize/de-energize when the set point is crossed. (See section IV.C.3 for set point adjustment procedure) The relay energizes on increasing or decreasing readings as set by the user, see section IV.C.1. When energized (above set point), the Common (COM) will disconnect from the Normally Closed (NC) contact and connect to the Normally Open (NO) contact. Devices may be operated using either the Normally Open contact or Normally Closed contact; or both relay contacts may be used to control two devices of the same voltage.

**NOTE:** A flow switch may be installed (electrically connected) utilizing one of two convenient methods; the 3S connection, see figure II.E.2, (remove jumper and connect flow switch across terminals - 8" harness (RAH) available from the Myron L Company), or in-line with either relay connection, see figure II.E.6 or II.E.7.

**WARNING: CONNECTING BOTH POWER SOURCE LEADS TO THE RELAY TERMINAL BLOCK CONNECTORS WILL DAMAGE THE CIRCUIT BOARD AND MAY CAUSE PERSONAL INJURY.**

1. Place the user supplied Alarm relay interface cable and watertight cable restraint into the enclosure's appropriate access hole. Skip for OEM.
2. Neatly connect the relay interface cable wires to the Monitor/controller's terminal block connectors, see figures II.E.1, II.E.6 or II.E.7.

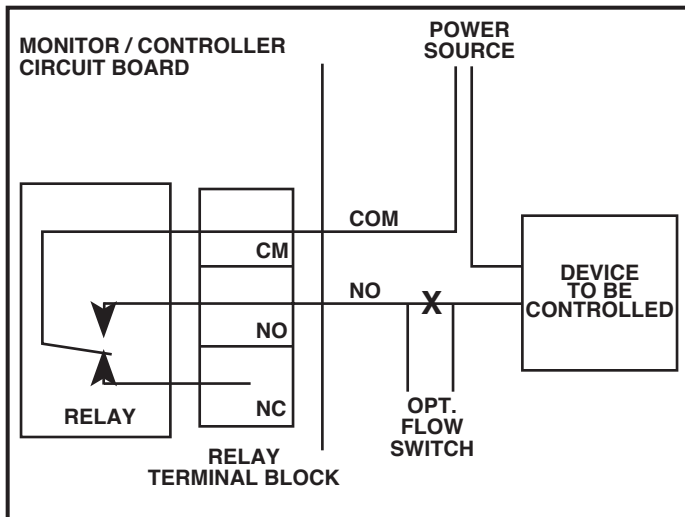


Figure II.E.6

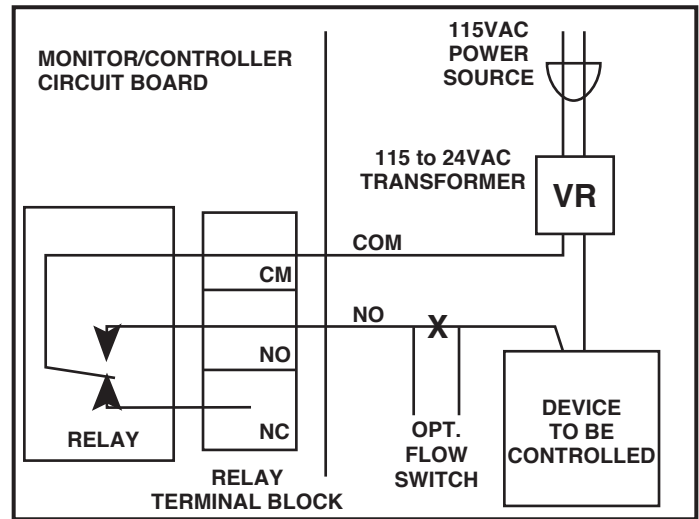


Figure II.E.7

**CAUTION:** The connectors require only a small screwdriver or a pen to push on the release levers. The release levers may be broken or damaged if not pushed straight toward the circuit board. DO NOT push the release levers sideways.

The easiest method of connecting the relay is shown in figures II.E.1, and II.E.6. These show how the dry contact relay can use incoming power to activate a controlled device (alarm, solenoid valve, etc.) of 10 amps or less.

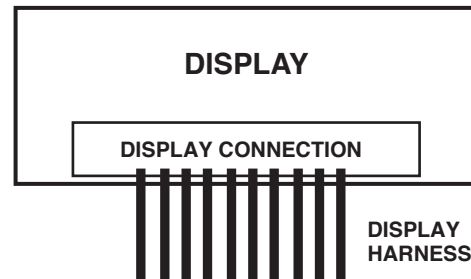
For 24 VAC applications, the Myron L Company offers a 115 VAC to 24 VAC transformer, Model #VR, see figure II.E.7. Other voltages must be user-supplied.

**6. CONNECTING DISPLAY HARNESS TO DISPLAY**

If the installation required the removal of the display harness from the display (OEM installation requires connection), the following procedure will ensure it is reinstalled without damaging the display.

**WARNING: THE DISPLAY WILL BE IRREPARABLY DAMAGED IF THE HARNESS IS INSTALLED UPSIDE-DOWN OR MISALIGNED. THE HARNESS MUST BE INSTALLED AS SHOWN IN FIGURE II.E.8.**

1. Grasp connector and align wires DOWN on display or with the small edge of the display as shown in figure II.E.8.
2. Press connector onto display pins. Ensure pins are aligned or they may become bent. Wiggle connector slightly "end to end" if necessary.



PANEL MOUNTED DISPLAY  
REAR VIEW  
Figure II.E.8

**F. 0-10 VDC RECORDER OUTPUT**

The 0-10 VDC output is designed to give the user the capability of sending a signal to a remote meter, recorder, PLC or SCADA system.

**1. CONNECTION**

1. Place the user supplied interface cable and watertight cable restraint into the enclosure's appropriate access hole. Skip for OEM.
2. Connect the Recorder's plus (+) and minus (-) terminal wires to the Recorder output connectors. (See figure II.E.1.)
3. Refer to Section V.C.1.b for the procedures to calibrate the 0-10 VDC voltage output.

**2. VOLTAGE DIVIDER**

A voltage divider gives the user the ability to scale or tailor the output to a particular need or requirement due to the input of another device, i.e. the output of the Main CB is 0-10V while the input requirement of a particular recording device is 0-5V.

**a. INSTALLATION**

Briefly—

Two resistors are installed across the 0-10V output. The output is recalibrated to required voltage.

**Requirements**

- Select two (2) resistors as listed;
- For 0-5V Output both "A & B" are 2K Resistors.
- For 0-1V Output "A" is a 9K resistor and "B" is a 1K resistor.



**CAUTION - READ FOLLOWING CAREFULLY**

**WARNING: BEFORE STARTING, IF MONITOR/CONTROLLER IS INSTALLED, ENSURE THE POWER IS OFF. FAILURE TO DO SO COULD CAUSE DAMAGE TO THE INSTRUMENT, AND COULD BE HARMFUL OR FATAL TO PERSONNEL. ONLY QUALIFIED PERSONNEL SHOULD INSTALL ELECTRICAL EQUIPMENT.**

**Physical**

If the front panel has all ready been removed from the enclosure skip to #3.

1. Using a standard slot screwdriver remove the four (4) screws on the front panel.
2. Carefully wiggle the front panel to loosen and pull gently toward you. Do not pull more than about 8 inches/20CM or you could damage the wiring harness.
3. Turn the front panel around so that the back side is facing you and set aside for now.
4. Solder two selected resistors together as shown in figure II.F.1.
5. Attach leads to recording device as shown in figure II.F.1.
6. Attach resistors to 0-10V Output as shown in figure II.F.2.  
Ensure resistors and leads DO NOT short to each other or to any part of the CB assembly.
7. Recalibration is required, see Calibration Procedures, section V.C.

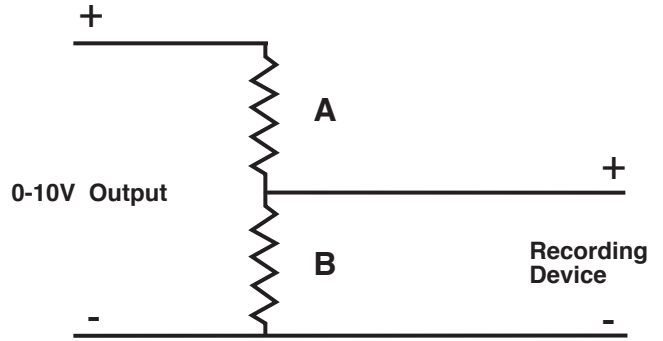


Figure II.F.1

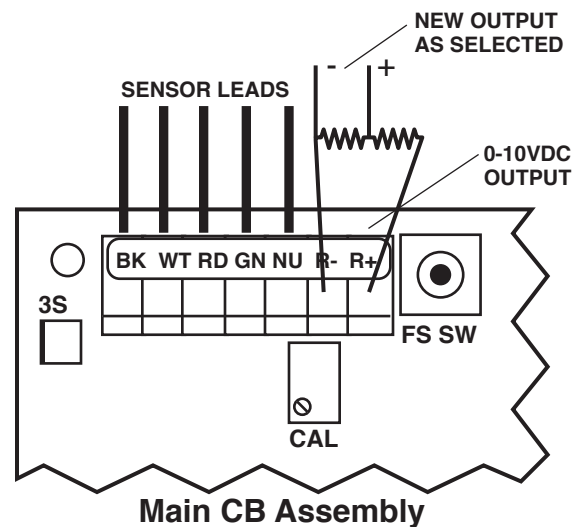


Figure II.F.2

**Reassembly**

1. Carefully reinstall the front panel, bottom first, ensure no wires have been pinched.
2. Reinstall the four (4) screws and tighten.
3. To operate, turn power **ON**.

**G. RE-RANGE YOUR MONITOR/CONTROLLER  
(Range Module Installation)**

**1. DESCRIPTION**

The 750 Series II Monitor/controllers have been designed for easy field re-rangeability. The Range Module consists of a 16 pin Header that plugs into a 16 pin socket.

For available ranges, see Range Selection Guide I.G. When making large range changes, i.e. 5000 ppm to 50 ppt, a different sensor may also be required as noted in the Range Selection Guide. Order Range Module by adding the prefix "RM" to the range number as in examples below.

Conductivity/TDS Range Modules —  
 RMXXX i.e. = RM121 is a 0-2000µS  
 Resistivity Range Modules —  
 RMXX i.e. = RM11 is a 0-20MΩ

**NOTE:** Some OEM models may not be re-ranged being originally manufactured with a fixed range. If your application requires re-ranging an OEM model, first contact the system manufacture for help. The Myron L Company may re-range or exchange your instrument at a cost.

**2. INSTALLATION**

Briefly -  
 The new Range Module simply replaces the Range Module presently installed, see figure II.G.1.  
 Multiplier label is added to analog models\*.  
 Type label may be required if changing from Microsiemens to Millisiemens or PPM/PPT.  
 The Full Scale reading is recalibrated.

**IMPORTANT NOTES:**

1. When changing ranges on Digital Monitor/ controllers with the -45 option (4 1/2 digit backlit display), the following modifications may be required to the range module; RM123 thru 128 and RM16 require pin number 9 be removed or bent toward the side, see Fig. II.G.2. On RM117 thru 122 a jumper wire must be soldered to the RM, see Fig. II.G.3.  
 \*2. Analog Monitor/controllers may require a scale change. See section II.G.3 for the specific instructions.

**CAUTION - READ FOLLOWING CAREFULLY**

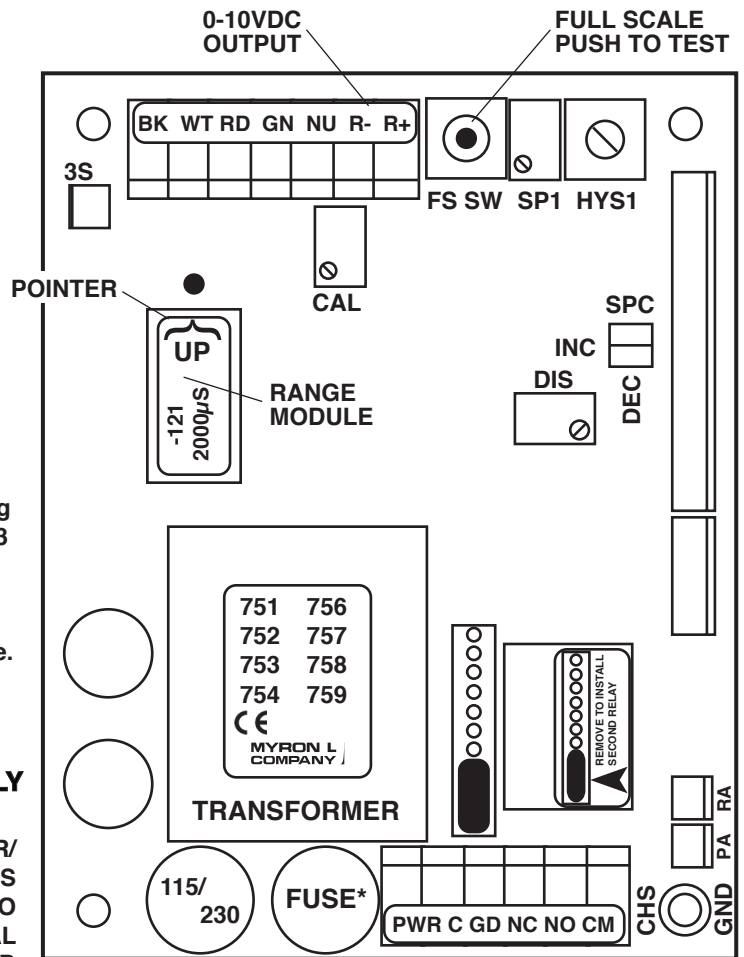
**WARNING: BEFORE STARTING, IF MONITOR/CONTROLLER IS INSTALLED, ENSURE THE POWER IS OFF. FAILURE TO DO SO COULD CAUSE DAMAGE TO THE INSTRUMENT, AND COULD BE HARMFUL OR FATAL TO PERSONNEL. ONLY QUALIFIED PERSONNEL SHOULD INSTALL OR SERVICE ELECTRICAL EQUIPMENT.**

**Physical**

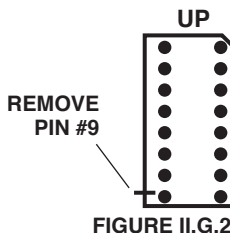
**NOTE:** When opening instrument, remove front cover with care; a ribbon cable connects the front panel and main board. If the front panel has already been removed from the enclosure skip to #4.

1. Using a standard slot screwdriver remove the four (4) screws on the front panel.
2. Carefully wiggle the front panel to loosen and pull gently toward you. Do not pull more than about 8 inches/20CM or you could damage the wiring harness.

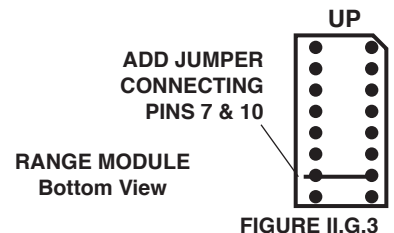
3. Turn the front panel around so that the back side is facing you and set aside.
4. Locate and remove existing Range Module from MAIN Circuit Board, as shown in figure II.G.1. It is not easy to remove, it was designed to stay in place under adverse conditions.
5. With the pointer up, carefully align the new Range Module to the socket on the MAIN Circuit Board as shown in figure II.G.1.
6. Press firmly into place.
7. For analog models, add multiplier label to front panel. See figures II.G.10 and II.G.11 for suggested locations. In some cases changing the meter scale will be necessary. See Changing Analog Meter Scale, section II.G.3.
8. Recalibrate, see CALIBRATION PROCEDURES, section V.C.



**Main CB Assembly  
Figure II.G.1**



**FIGURE II.G.2**



**FIGURE II.G.3**

**DIGITAL 4 1/2 DIGIT LCD  
MONITOR/CONTROLLERS ONLY**

### 3. CHANGING ANALOG METER SCALE (DIAL)

After changing ranges on an analog model 750II it may be necessary to change the meter scale (dial). The following steps will guide you through the change. Please read caution carefully.



#### CAUTION - READ FOLLOWING CAREFULLY

Exercise extreme caution while working on meter. Meter movement, and/or pointer (needle) may be damaged beyond repair. It is recommended only qualified personnel change scales.

DO NOT allow dust to enter the case while it is open. Failure to follow these instructions may cause irreparable damage, and will VOID the warranty.

Briefly -

The meter is removed from front panel (except OEM models).

The cover is removed.

The hex screws retaining the scale are removed, and scale is slid out the top.

New scale is slid in place, and screws reinstalled.

Cover aligned, installed and zero set.

#### Physical

For OEM models skip to #4.

1. Using a wrench, nut driver or pliers remove the two (2) large nuts retaining the circuit board wiring harness connectors. Red wire is PLUS (+), Brown wire is MINUS (-). See figure II.G.4.
2. Using a standard slot screwdriver remove the four (4) screws, and the backing plate holding the meter to the front panel as shown in figure II.G.4.
3. Remove meter. Do not lose the gasket between the meter and the front panel it must be reinstalled upon reassembly. See figure II.G.5. Align gasket to front panel so as the gasket does not show when meter is assembled to front panel.

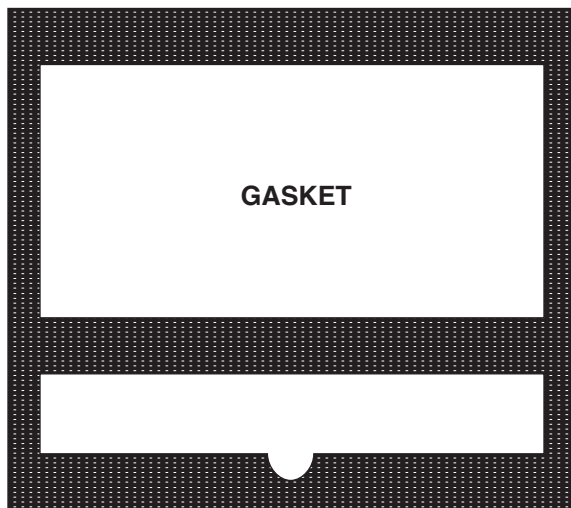


Figure II.G.5

4. Using a wide blade standard slot screwdriver, starting at a bottom corner, CAREFULLY pry the clear plastic cover loose from the movement case. See figure II.G.6.
5. Using a 1/8" (3.2mm) hexdriver, remove the two (2) small screws holding the scale (dial). See figure II.G.7.

6. To remove the scale, lightly press on bottom of scale, the top will lift up. Be extremely careful not to bend the pointer (needle) or to move the Zero Adjust (ZA). See figure II.G.7.

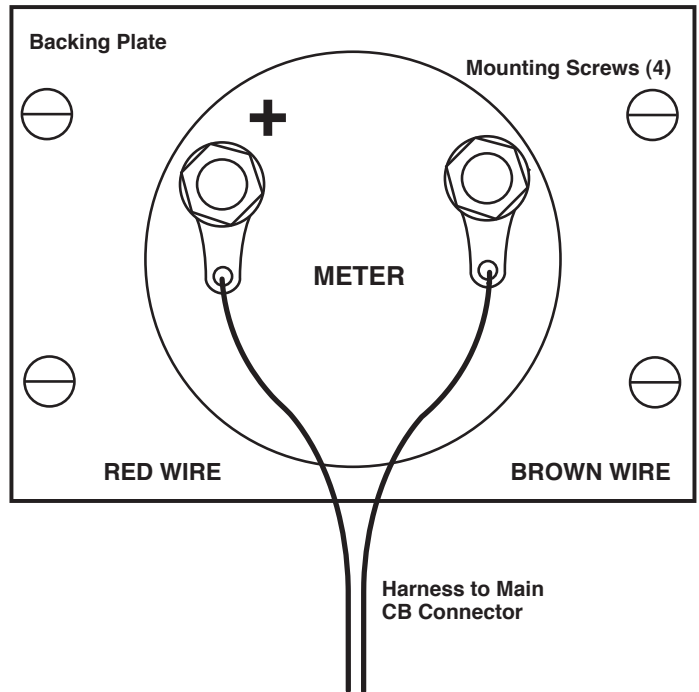


Figure II.G.4

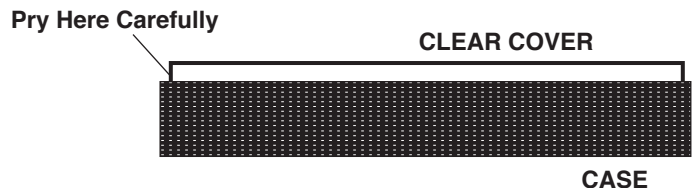


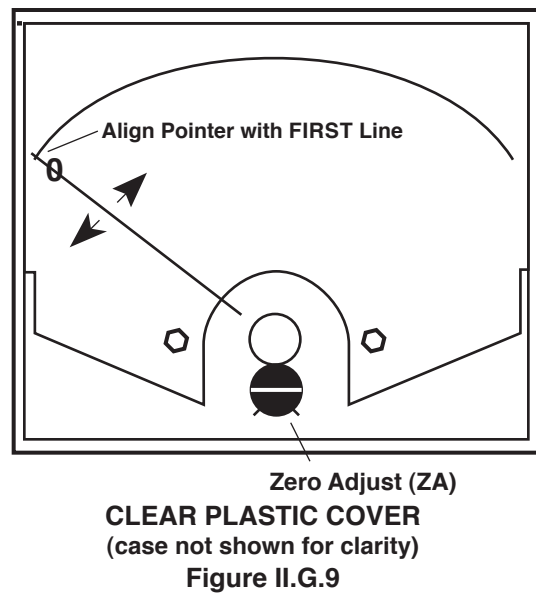
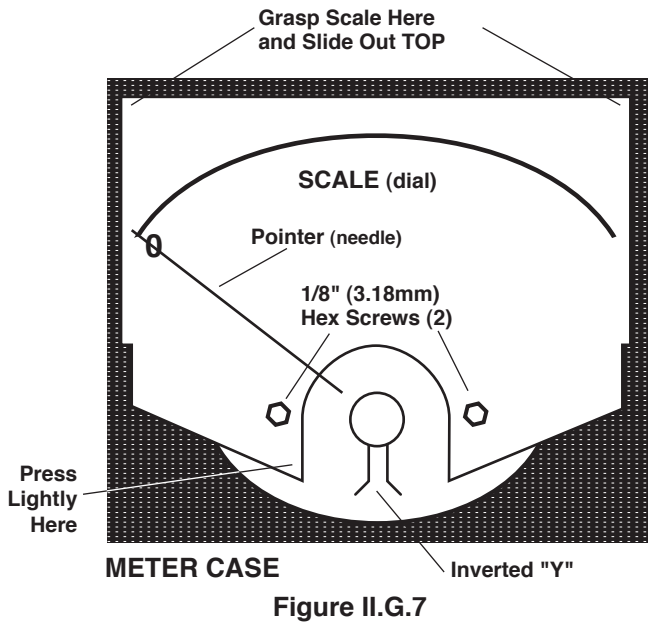
Figure II.G.6

7. Grasp top and slide scale slowly out from top. Be extremely careful not to bend the pointer (needle) or to move the Zero Adjust (ZA). See figure II.G.7.
8. Reverse the above procedure using the new scale.

**NOTE:** While replacing the clear plastic cover, ensure the ZA screw pin on the cover aligns with the inverted "Y" shaped slot on the meter movement. See figure II.G.7.

IF, the inverted "Y" shaped slot is inadvertently moved - BEFORE installing cover:

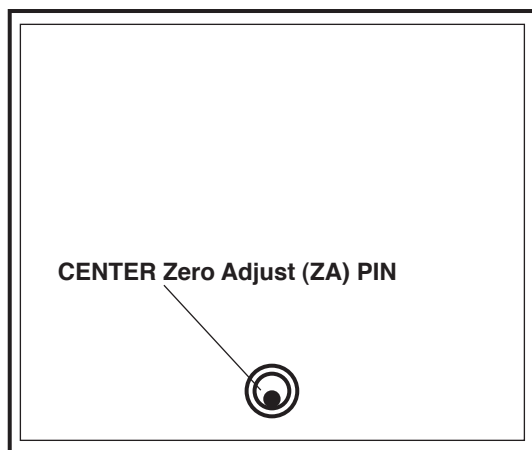
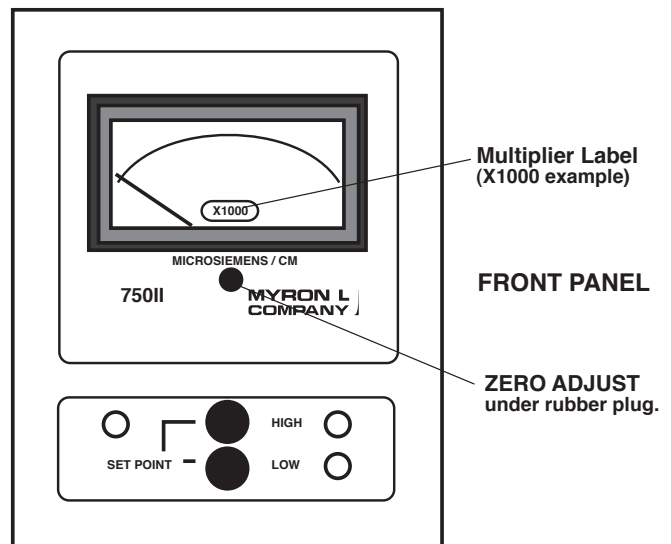
- a. Re-center the inverted "Y" to the meter case as shown in figure II.G.7.
  - b. Center the Zero Adjust (ZA) PIN on the clear plastic cover as shown in figure II.G.8.
9. Using a standard slot screwdriver, ensure the ZA is operating - pointer swings left and right when turning the ZA with a standard slot screwdriver. See figure II.G.9.
  10. Set Meter ZERO as shown in figure II.G.9.
  11. Reinstall meter to front panel, reversing steps 1-3 (except OEM models).



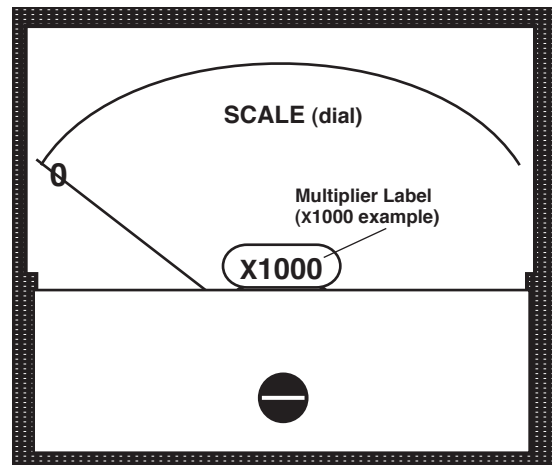
#### 4. LABEL CHANGE

Since you have re-ranged your Monitor/controller it may be necessary to relabel it. If you made any one of the following changes it will be necessary to "add or change" the designator label on the Front Panel. Pick the correct label and apply to the Front Panel as shown in figure II.G.10. If there is an overlay label already in place remove it and clean the surface with isopropyl alcohol (rubbing alcohol) before installing the new label. A clean surface will allow the new label to adhere to the surface better.

1. Did you change from  $\mu\text{S}$  to  $\text{mS}$ ,  $\text{PPM}$  or  $\text{PPT}$ ?
2. Did you change from  $\text{mS}$  to  $\mu\text{S}$ ,  $\text{PPM}$  or  $\text{PPT}$ ?
3. Did you change from  $\text{PPM}$  to  $\text{PPT}$ ,  $\mu\text{S}$  or  $\text{mS}$ ?
4. Did you change from  $\text{PPT}$  to  $\text{PPM}$ ,  $\mu\text{S}$  or  $\text{mS}$ ?
5. Do you need to install a Multiplier label as in figure II.G.11.



CLEAR PLASTIC COVER  
(Inside View)  
**Figure II.G.8**



OEM ANALOG METER  
**Figure II.G.11**

#### REASSEMBLY

1. Carefully reinstall the front panel, bottom first, ensure no wires have been pinched.
2. Reinstall the four (4) screws and tighten.
3. To operate, turn power **ON**.

### III. OPTIONS & ACCESSORIES

#### A. SC/SCO MODULE (SECOND ALARM/CONTROL OPTION) (Digital & OEM Models ONLY)

- SC Second Alarm Control Module ordered with Monitor/controller.
- SCO Second Alarm Control Module Kit ordered separately.

##### 1. DESCRIPTION:

An essential component for applications requiring a DUAL setpoint. The Second Alarm/control module allows the user additional flexibility by being able to sound TWO Alarms, and Control TWO functions with the second 10 amp relay. The set points are non-overlapping. The #2 alarm/control (HIGH set point) rides on top of the #1 alarm/control (LOW set point). SCO kit comes with all items necessary to install and operate: SC Module, front panel harness with LED, switch, bezel, cap and two O-rings (006 & 008); and replacement lower front panel label (L2ALARM).

##### Specifications:

Control Function:

Setpoint control continuously adjustable 0-100% of span

Hysteresis:

Adjustable from 0.3-3% of full scale

Indicators:

Above (red) and below (green) setpoint LEDs (reversible)

Relay Contact Rating:

SPDT 10 amp ~ 250 VAC, 30 VDC. Relay operates increasing or decreasing reading (selectable)

Solid State Output:

Powered — 24VDC 30mA Maximum

##### 2. INSTALLATION:

Briefly -

The Second Alarm/control module plugs into the main Monitor/controller circuit board.

The LED/switch harness is installed into the front panel.

Set point and hysteresis are set per "your" requirements.

If this option is installed, skip to III.A.2.a.



#### CAUTION - READ FOLLOWING CAREFULLY

**WARNING:** BEFORE STARTING, IF MONITOR/CONTROLLER IS INSTALLED, ENSURE THE POWER IS OFF. FAILURE TO DO SO COULD CAUSE DAMAGE TO THE INSTRUMENT, AND COULD BE HARMFUL OR FATAL TO PERSONNEL. ONLY QUALIFIED PERSONNEL SHOULD INSTALL OR SERVICE ELECTRICAL EQUIPMENT.

##### Physical

If the front panel has all ready been removed from the enclosure skip to #3.

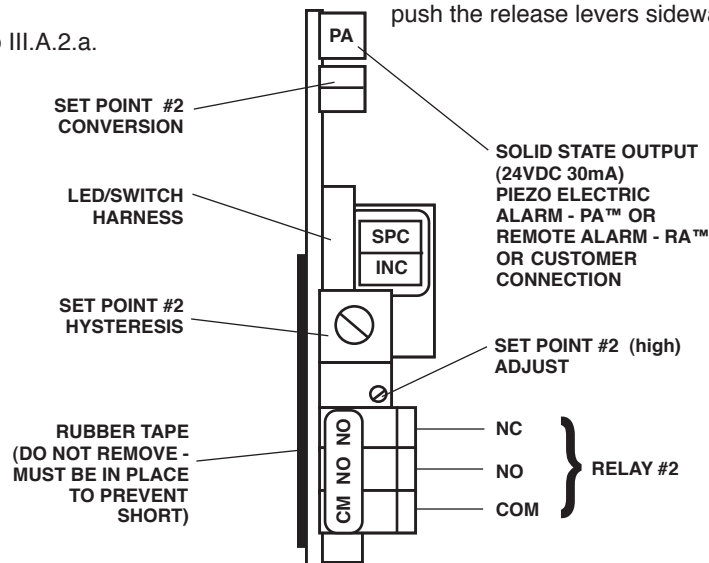
##### MAIN Circuit Board

1. Using a standard slot screwdriver remove the four (4) screws on the front panel.
2. Carefully wiggle the front panel to loosen and pull gently toward you. Do not pull more than about 8 inches/20CM or you could damage the wiring harness.
3. Turn the front panel around so that the back side is facing you and set aside for now.
4. Remove BLACK JUMPER from MAIN Circuit Board connector located next to the transformer as shown in figure III.A.2.

##### NOTE:

- Do not lose BLACK JUMPER. It must be reinstalled if second relay is removed for any reason and the #1 relay is expected to operate.
5. Carefully press the SCO Second Alarm/Control Module into MAIN Circuit Board as shown in figure III.A.4. When fully seated the SCO Module will snap into place.
  6. Connect the Solid State output to PA or user supplied 24VDC/30mA alarm/valve or ??, and/or control wires to relay #2, as required, see figure III.A.4\*.
    - a. Place the control cable and user supplied watertight cable restraint into the enclosure's appropriate access hole.
    - b. Neatly connect the control wires to the Monitor/controller's appropriate connectors. See figure III.A.4.

**\*CAUTION:** The relay connectors require only a small screwdriver or a pen to push on the release levers. The release levers may be broken or damaged if not pushed straight. DO NOT push the release levers sideways.



OPTIONAL SECOND ALARM/CONTROL MODULE  
Figure III.A.1

**Front Panel**

**WARNING:** There are two (2) O-rings installed on the switches, one (1) on the shank and the other is under the push button. Both of these O-rings must be reinstalled to maintain IP65/ NEMA 4X ratings. See figure III.A.3.

1-4 assumes this is a conversion from a single alarm/control. Skip to #5 if new installation or assembly.

1. Carefully remove the RED LED from the front panel by pulling lightly on the wires. It may be necessary to use a small flat screwdriver to slightly spread the retaining ring.
2. Remove the set point switch from the front panel by rotating the round bezel nut CCW on the front panel, see figure III.A.4.
3. Remove the LOWER front label.
4. Clean off remaining adhesive. Use alcohol, if possible.
5. Install DUAL alarm LOWER label, P# L2ALARM.
6. Install the SCO Second Alarm/Control RED LED in the UPPER position as shown in figures III.A.5 & III.A.6.

7. Install the SCO Second Alarm/Control Set Point Switch in the UPPER center position.
8. Re-install #1 (original) Set Point Switch in the LOWER center position.
9. Re-install the #1 (original) RED LED in the LOWER position.
10. The GREEN LED stays in the same location.

**a. Set Point Conversion (SPC) / Reversing Set Point**

The alarm/control circuit(s) on all 750 Series II Conductivity/TDS Monitor/controllers are configured to trigger the alarm relay as the Conductivity/TDS reading increases.

**NOTE:** On Resistivity Monitor/controllers the reverse is true, as the reading decreases the alarm/control will trigger/sound.

If the user's application requires it, the alarm/control circuit may be easily reconfigured to trigger the alarm/control relay as the Conductivity (or ppm) reading decreases, or increases for Resistivity. Refer to figure III.A.4 for the locations of the SPC jumpers referred to in this section.

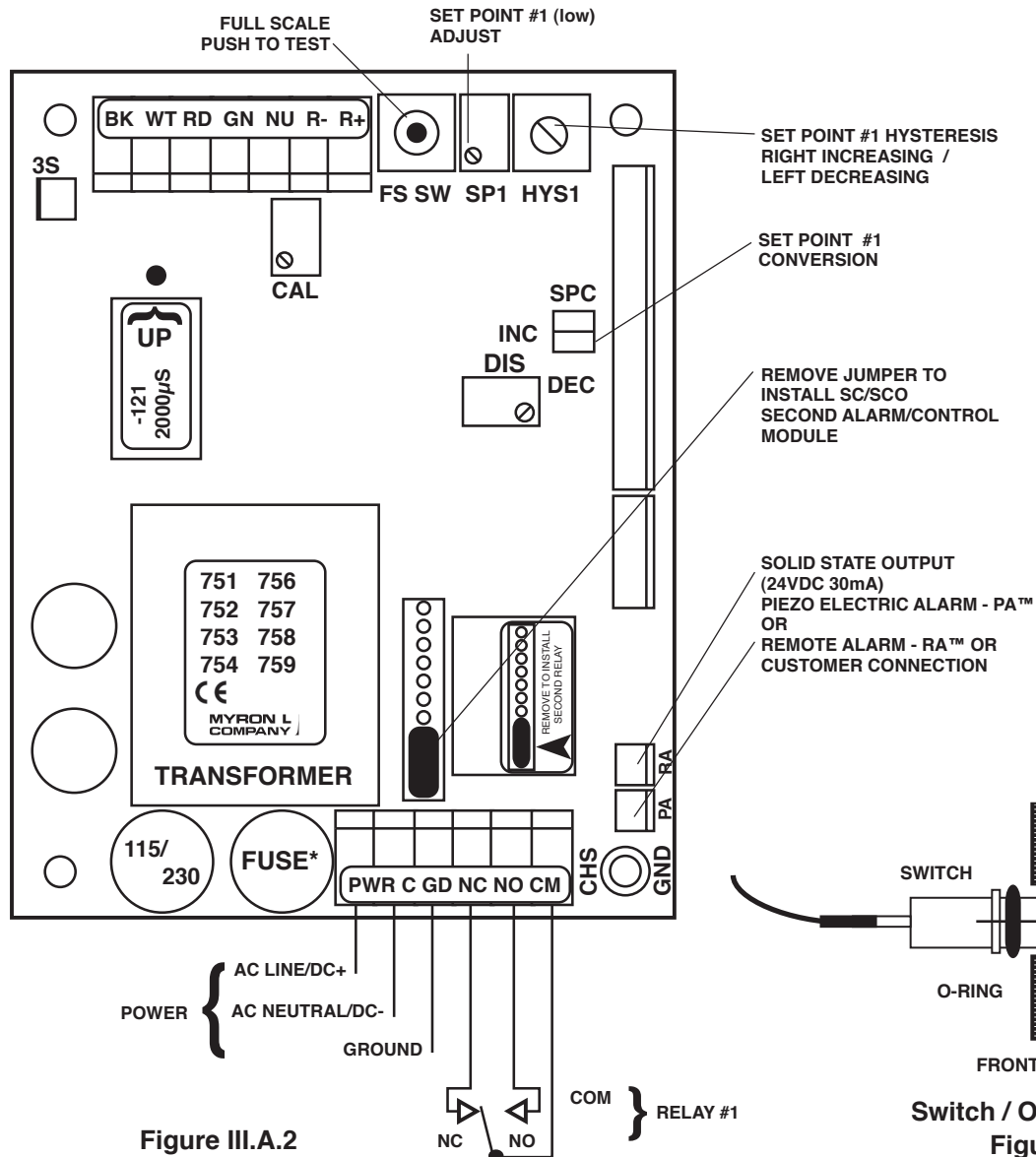
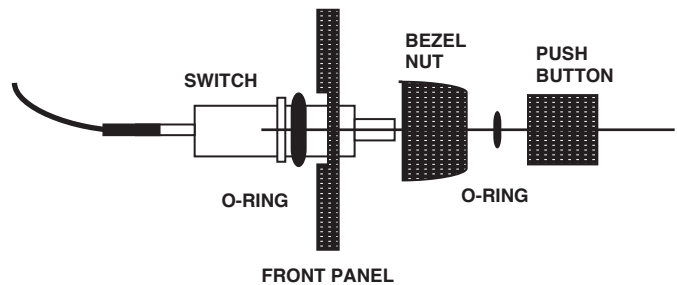


Figure III.A.2



Switch / O-ring Assembly  
Figure III.A.3



The following instructions describe the steps for converting the Monitor/controller. Refer to figure III.A.4 for the location of the SPC(s) on your Monitor/controller. If unnecessary, skip to Set Point Adjustment.

1. Ensure power is **OFF**.
2. Locate the SPC jumpers for the alarm to be configured, see figure III.A.4.
3. Make a note of the current orientation of the SPC jumpers.
4. Remove both jumpers. This is easily done by hand. Take care not to crush the jumpers if using pliers.
5. Rotate the jumpers 1/4 turn (90°) and reinstall them on their posts.
6. Continue with Set Point adjustment.

**b. Set Point Adjustment**

Set point #1 (LOW) must be adjusted **BEFORE** adjusting set point #2 (HIGH).

1. Turn power **ON**.
2. While depressing the lower "SET POINT" switch, turn the Set Point #1 adjustment, figure III.A.4 until the desired set point value is indicated on the display.
3. Repeat for Set Point #2 by depressing the upper "SET POINT" switch and adjusting the SP2 on the SC/SCO Module as shown in figure III.A.4.
4. Turn power **OFF**.
5. Continue or reinstall the front panel and tightly secure both retaining screws, see REASSEMBLY below.

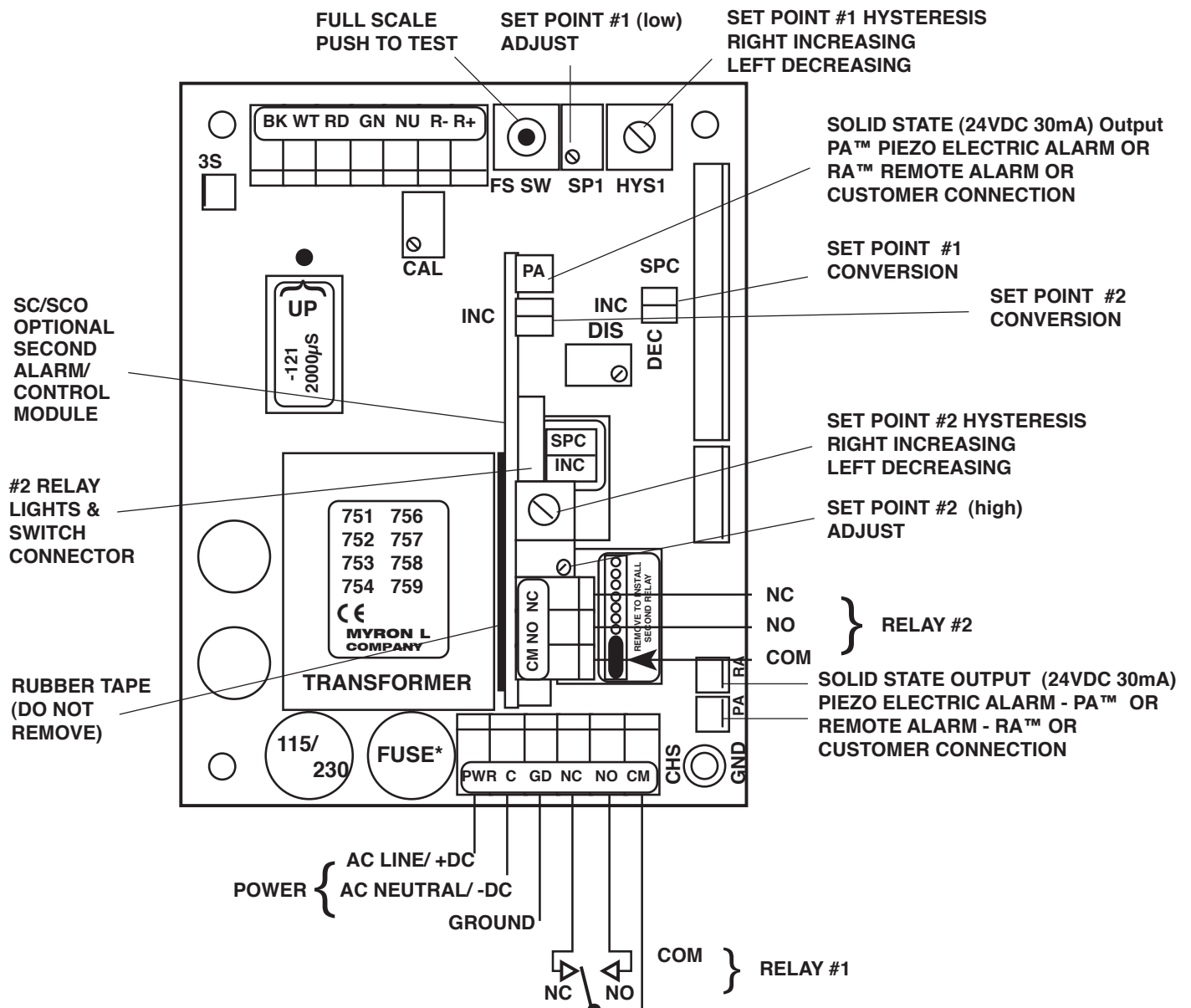


Figure III.A.4

### c. Hysteresis (Dead Band) Adjustment\*

The hysteresis or dead band is approximately  $\pm 3\%$  of the set point at full scale as it leaves the factory. Under normal (most) conditions it will not be necessary to adjust. However, if you desire to make an adjustment please keep the following in mind.

The adjustment is very simple and is based on set point location. If the set point\* is in the upper 75-100% of the scale, the hysteresis control pot should be turned fully to the right. If the set point is in the lower portion of the scale, i.e. 5-25% of scale, the control pot may be turned fully to the left. If you are operating in the center, 25-75% of scale, the control pot may be adjusted in the center. Or the hysteresis or dead band may be adjusted to tighten the control of a particular process.

**CAUTION:** Adjusting the hysteresis too narrow may cause the alarm to fluctuate (on-off) due to flow, chemical mixing or bubbles causing the relay to chatter. This condition is to be avoided, it could damage your valves, pumps, etc. and will eventually damage the relay.

\* Applies to both set points.

The following is assuming the front panel is already removed and the set points have been set, if not, see "Set Point Adjustment".

1. Turn power **ON**.
2. Locate the Hysteresis Control (HYS1) located next to the Set Point #1 (SP1) adjustment - it is a single turn pot. See figure III.A.4.
3. Adjust as described in "Hysteresis (Dead Band) Adjustment" or as desired.
4. Press set point test switch on the front panel to verify Hysteresis is set as desired.
5. Repeat for SCO Module. See figure III.A.4.
6. Press set point test switch on the front panel to verify Hysteresis is set as desired.
7. Turn power **OFF**.

### d. Second Relay Connection

1. Place the user supplied relay interface cable and watertight cable restraint into the enclosure's appropriate access hole.
2. Neatly connect wires to the relay connector as shown in figure III.A.4.

### e. Solid State Output Options

24VDC Unregulated 30mA max.

Same as 4. above, SOLID STATE OUTPUT.

1. **Piezo Electric Alarm - PA (option)**  
Plug PA connector to CB as shown (See Figure III.A.4).
2. **Remote Alarm - RA™ (option)**  
Plug RA connector to CB as shown (See Figure III.A.4).
3. **Connect to your own alarm or ?**

Ensure your requirements do not exceed the 24VDC Unregulated 30mA maximum.

Ensure the polarity is correct.

Attach your wires.

Attach harness connector to controller connector (RA) per figure III.A.4.

If necessary, you may order connector with 8" Harness part #RAH, from the Myron L Company.

### REASSEMBLY:

1. Carefully reinstall the front panel, bottom first. Ensure no wires have been pinched between enclosure and front panel.
2. Reinstall the four (4) screws and tighten.
3. To operate, turn power **ON**.

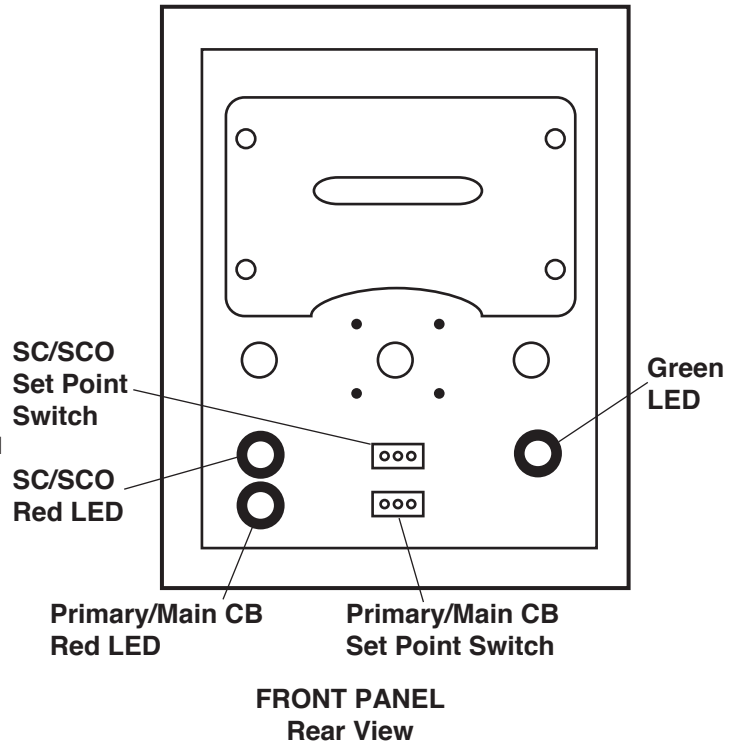


Figure III.A.5

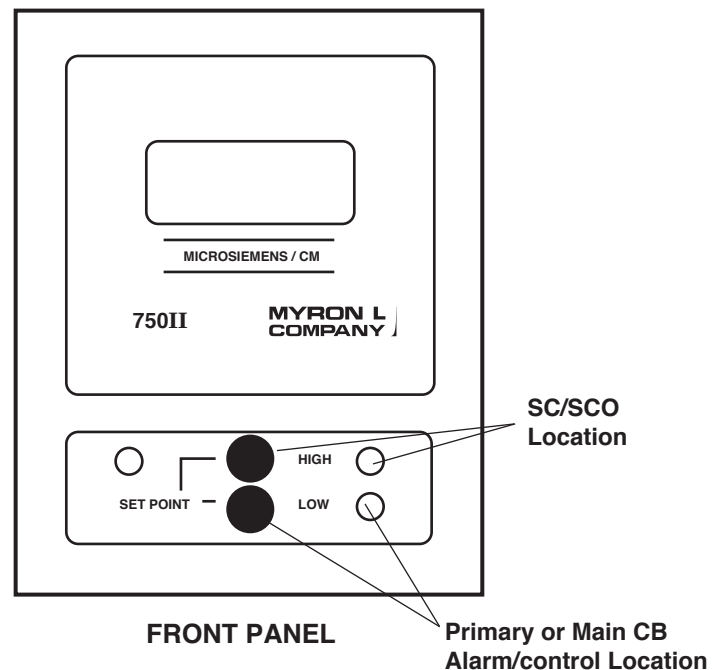


Figure III.A.6

**B. 4A/4AO MODULE (4-20mA OPTION)**

Available only on the digital models 758II, 759II, 753II and 754II, or all analog and digital OEM Monitor/controllers.

- 4A 4-20mA Self/Remote-powered Isolated output module ordered with Monitor/controller.
- 4AO 4-20mA Self/Remote-powered Isolated output module ordered separately (includes harness).

**1. DESCRIPTION**

The 4-20mA option gives the Series II Monitor/controller the ability to send a signal very long distances with minimal interferences and signal degradation. The output is an Isolated 4-20mA signal that corresponds to the full scale range of the Monitor/controller into which it is installed. This output is easily configured to be either self-powered or remote-powered as required for your particular application.

**NOTE:** The maximum impedance of the user's current input instrument should not exceed 600 ohms.

low as 10Ω. This “-4A” option will drive any impedance from 0 to 600Ω without any degradation of performance.

There are two modes in which current loop transmitters operate; Self-Powered and Remote-Powered.

Self-Powered — the transmitter provides the power to drive the 4 to 20 mA current. See figure III.B.1.

Remote-powered — the receiving instrument provides the power to drive the 4 to 20 mA current. See figure III.B.2.

**Specifications**

Self-Powered and Remote-Powered

Drive Impedance — 0 to 600Ω

Common Mode Maximum — 120VAC @ 60 Hz

Isolation — 100pf max. to Model 750II circuit common  
100pf max. to input power line

**Calibration**

Two multi-turn pots — Factory Set.

4mA = Zero (0)

20mA = Full Scale

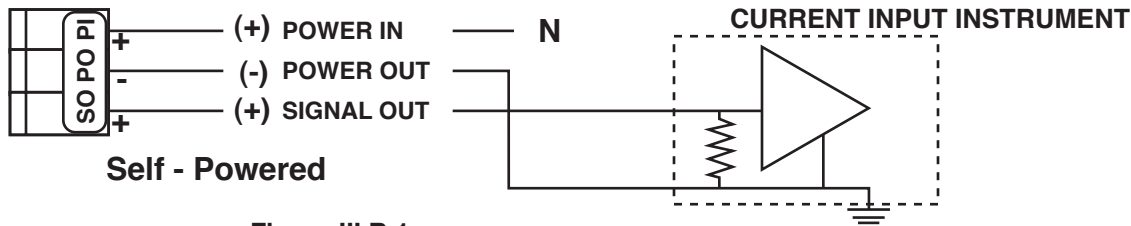


Figure III.B.1

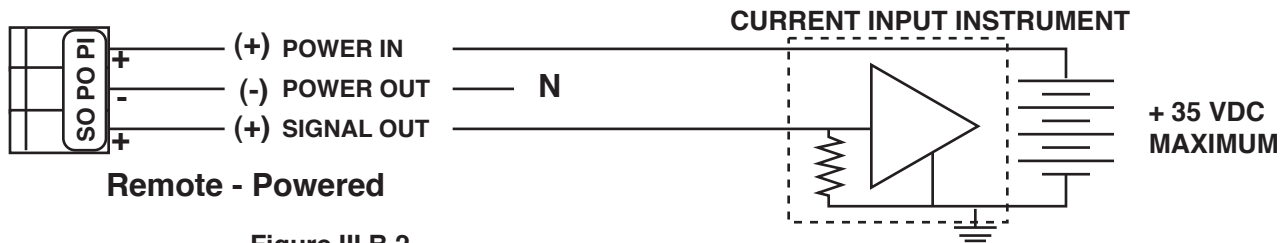


Figure III.B.2

**4A (4-20mA) Wiring Options**

Since the output is an isolated current loop, it is the ideal choice for applications requiring; a control signal to be run very long distances, systems requiring a 4-20mA input or in instances where isolation is necessary.

As the output is isolated, and a current, it is useful for long distance interface, especially where wiring resistances may be high, and/or the ground potentials may differ between the sensor input ground and the current receiving instruments ground.

The 4-20mA output will not be degraded in accuracy even when the ground differences are as much as 120VAC @ 60Hz. Interface wire resistance of 350Ω will not degrade the accuracy of the output when interfaced to a typical 250Ω input impedance of a transmitter current input device.

The output is capable of driving a minimum of 600Ω worst case, therefore, will satisfy virtually all modern interface requirements. Current input devices usually have an input impedance of 250Ω, however, some older designs can have as high as 500Ω or as

Calibration is NOT required. However, if you feel you must verify or recalibrate, see Recalibration below.

**2. INSTALLATION**

Briefly -

The 4-20 Module replaces the plastic display retainer plate attached to the front panel.

The 4-20 Module harness is attached to the main circuit board as marked '4-20'. See figure III.B.4.

The 4-20 output is wired as required - Self-powered or Remote-powered. See figures III.B.1 & III.B.2.



**CAUTION - READ FOLLOWING CAREFULLY**

**WARNING: BEFORE STARTING, IF MONITOR/CONTROLLER IS INSTALLED, ENSURE THE POWER IS OFF. FAILURE TO DO SO COULD CAUSE DAMAGE TO THE INSTRUMENT, AND COULD BE HARMFUL OR**

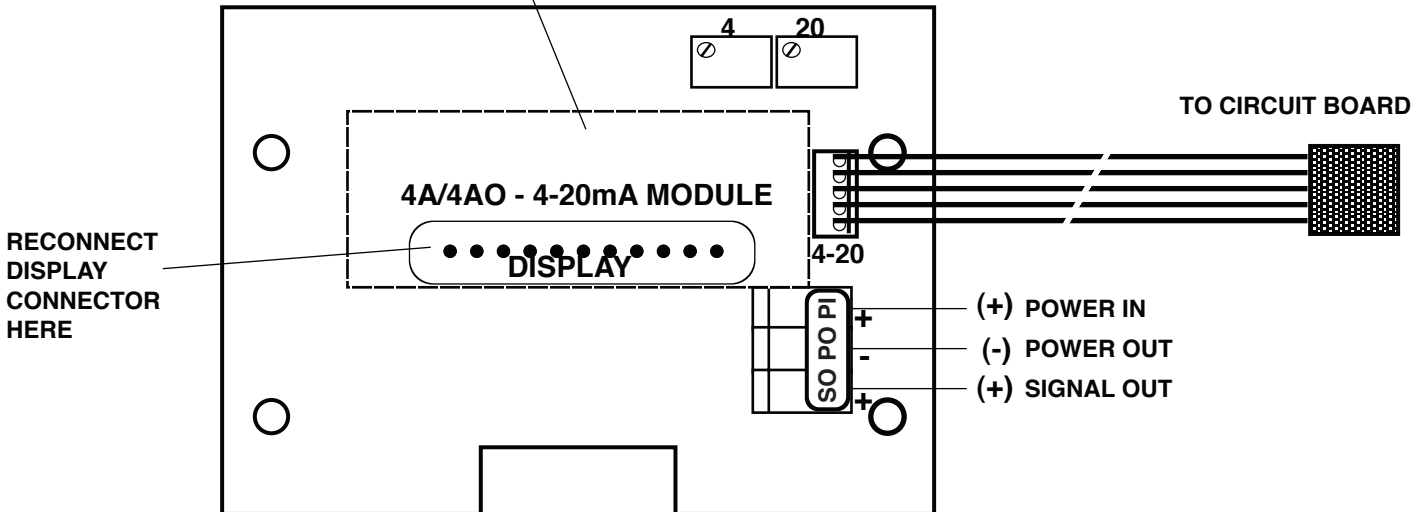
**FATAL TO PERSONNEL. ONLY QUALIFIED PERSONNEL SHOULD INSTALL ELECTRICAL EQUIPMENT.**

**Physical**

If the front panel has all ready been removed from the enclosure skip to #3.

1. Using a standard slot screwdriver remove the four (4) screws on the front panel.
2. Carefully wiggle the front panel to loosen and pull gently toward you. Do not pull more than about 8 inches/ 20CM or you could damage the wiring harness.
3. Turn the front panel around so that the back side is facing you.

**DISPLAY IS ON BACK SIDE OF 4-20 MODULE**



**Figure III.B.3.**

4. Using a standard slot screwdriver remove the four (4) screws holding the plastic display retainer plate to the front panel. When the screws have been removed, the plastic display retainer plate and the display will be free from the front panel.
5. Set front panel down or carefully allow to hang from the harness. Do not drop as the harness connector will pull out allowing the front panel to fall.
6. While holding the display and the plastic display retainer plate, carefully remove the display harness connector. Do not drop the display. Remove and discard the plastic display retainer plate.
7. While still holding the display in the palm of your hand, set the 4-20 Module over it with the display pins protruding through the center opening as shown in figure III.B.3.
8. Reconnect the harness to the display as shown in figure III.B.3.
9. While holding the front panel, align the display to the opening while at the same time align the 4-20 Module mounting holes to the front panel.
10. Reinstall the four (4) screws and tighten.

**Electrical**

1. Connect the 4-20 Module (five) 5 wire harness to the main circuit board at the location next to the display harness marked "4-20" as shown in figure III.B.4.
2. Connect the signal and power wires as required, as

shown in figures III.B.1. & III.B.2. This assumes you have already connected the other end of the wires as required.

- a. Place the remote interface cable and user supplied watertight cable restraint into the enclosure's appropriate access hole.
- b. Neatly connect the signal cable wires to the Monitor's appropriate connectors as shown in figure III.B.3.
3. To test, turn power **ON**.
4. Press the Full Scale Test switch and monitor the output at your remote site, or with a DVM set to DC milliamps. Attach the DVM to the output connectors per your requirements, i.e. self-powered or remote-powered, see figures III.B.1. & III.B.2. If the 4A module is connected properly it will indicate 20mA.

5. Turn power **OFF**.
6. Carefully reinstall the front panel, bottom first, ensure no wires have been pinched between enclosure and front panel.
7. Reinstall the four (4) screws and tighten.
8. To operate, turn power **ON**.

**3. RECALIBRATION**

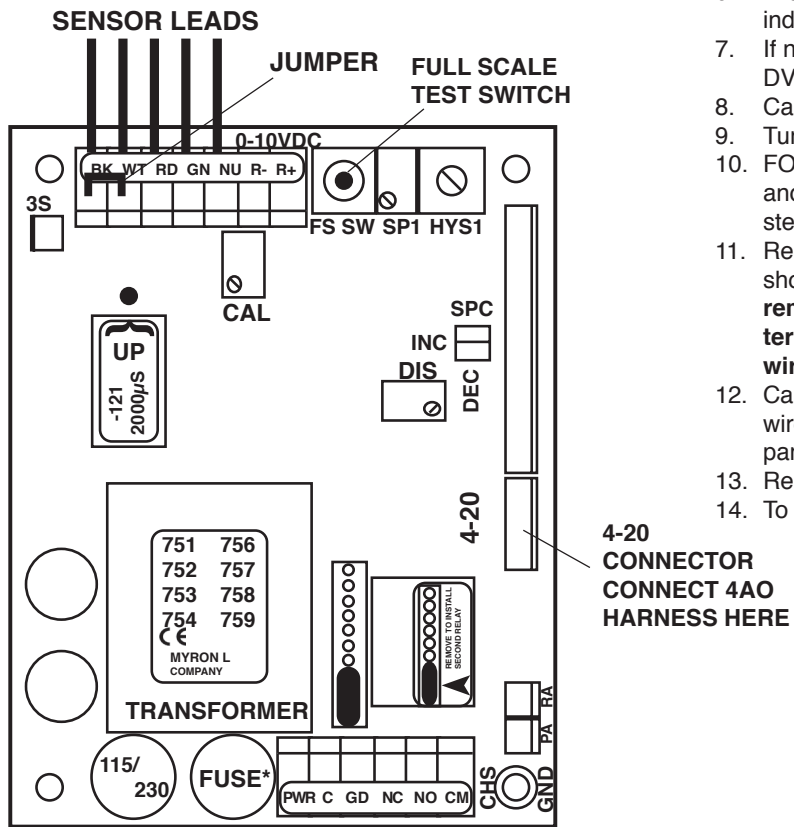
The 4-20 Module was calibrated at the factory; however, if you wish to check the calibration the following procedure will help you to accomplish this task. Exercise caution while performing this procedure.

Requirements; a DVM set to DC milliamps, a tweaker or small standard slot screwdriver.

This procedure assumes the front panel is removed.

**For Resistivity models, please follow special notes (\*)**

1. If sensor is connected, disconnect sensor wires from sensor terminal block. (\* **For Resistivity models, connect the sensor wires (red, green, & neutral) into the sensor terminal block. Use a jumper to bridge the black and white terminals together.**)
2. Attach the DVM to the output connectors per your requirements, i.e. self-powered or remote-powered, see figure III.B.5.
3. **FOR RESISTIVITY ONLY:** Add jumper between Black(BK) and White(WT) connectors, see Figure III.B.4. For Conductivity, go to step 4.
4. Turn power **ON**, with the front panel meter/display at ZERO, the DVM should indicate 4 milliamps.



MAIN CIRCUIT BOARD ASSEMBLY  
Figure III.B.4.

5. If not, adjust the CAL control marked "4mA" until the DVM indicates 4mA, see figure III.B.3.
6. Press the Full Scale Test Switch, the DVM should indicate 20 milliamps.
7. If not, adjust the CAL control marked "20mA" until the DVM indicates 20mA. See figure III.B.3.
8. Calibration is complete
9. Turn power **OFF**.
10. FOR RESISTIVITY: Remove jumper from Black(BK) and White(WT) connectors. For Conductivity, go to step 11.
11. Reconnect sensor wires to sensor terminal block as shown in figure III.B.4. (**\*For Resistivity models, remove the jumper from the black and white terminals and install the black and white sensor wires.**)
12. Carefully reinstall the front panel, bottom first, ensure no wires have been pinched between enclosure and front panel.
13. Reinstall the four (4) screws and tighten.
14. To operate, turn power **ON**.

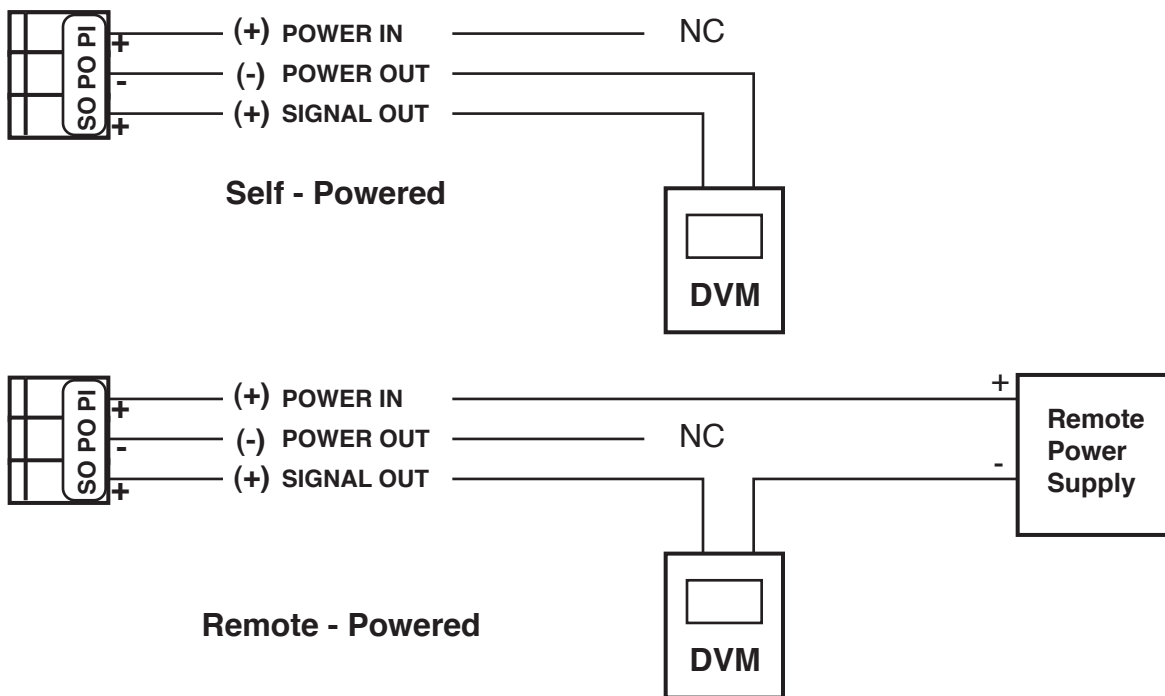


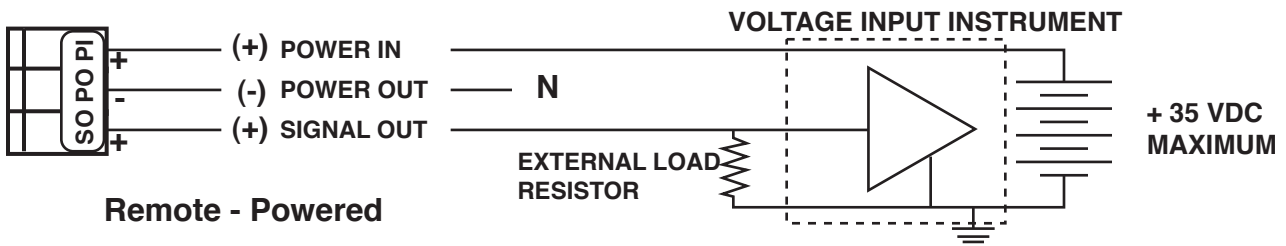
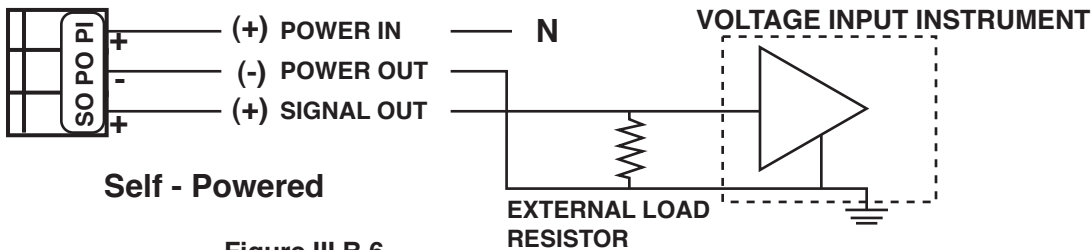
Figure III.B.5.

#### 4. CONVERTING A CURRENT TO A VOLTAGE

Current measuring devices actually measure voltage, but have an internal resistor as shown in figures III.B.1 & III.B.2 and are scaled to display in current. If you have a voltage input instrument and you wish to utilize the current from the 4A (4-20mA) Module, the following will help you to make this conversion.

To convert a 4-20 mA current output to operate or drive a voltage input device it is necessary to install a LOAD resistor across the input terminals as shown in figures III.B.6 & III.B.7. The value of the resistor is chosen to match the input voltage range, i.e. 0-10 Volts requires a 500Ω resistor and will produce a 2 to 10 input voltage. This floating zero is useful to indicate a broken 4-20 input wire when the indication is zero volts.

For an input voltage range of:						
10.0 Volts	the resistor value is	500 ohms	indicates	2.0 V	@	4 mA
5.0 Volts	"	250 ohms	"	1.0 V	@	4 mA
1.0 Volts	"	50 ohms	"	0.2 V	@	4 mA
100 millivolts	"	5 ohms	"	20 mV	@	4 mA
10 millivolts	"	0.5 ohms	"	2 mV	@	4 mA



For other input ranges, divide the input voltage range by 0.02, the answer will be in ohms.

**NOTE:** The tolerance of the load resistor directly affects the accuracy of the resulting voltage, i.e. 5% resistor = 5% error.

**C. TEMPERATURE MODULE**

(Digital Models only)

- TP Temperature Module ordered with Monitor/controller.
- TPO Temperature Module Kit ordered separately.  
Requires; CSXX-TP sensor, Special Order, i.e. CS51-TP or CS40-TP, see sensor data sheet.

**NOTE:** OEM models require an additional display harness, part number TPMH. See OEM Installation.

**1. DESCRIPTION**

The Temperature Module (TP) gives the Monitor/controller more flexibility for the user by being in the same package.

The Temperature Module is driven by the main display output and is very simple to install.

The Temperature Module and Temperature Sensor SYSTEM utilize a unique 3 wire technique by which errors are greatly reduced.

The Temperature Module has its own 0-5VDC output.

TPO kit comes with all items necessary to install and operate: TP Module; front panel harness with switch, bezel, cap and two O-rings (006 & 008); and TEMPERATURE label (# LTEMP).

An alarm/control function may be added to the TP by ordering the THO harness kit.

**NOTE:** Only one CSXX-TP sensor may be used with the 3SO/3SE option. Requires the CSXX-TP sensor temperature wires be routed directly to the TP/TPO CB.

**Specifications**

- ±200°C (±200°F Special Order Only)
- Accuracy: ±0.2 w/ICE ±0.5 w/out ICE
- Display Resolution = 0.1
- Output: 0-5VDC Connections - 2
- Sensor Input: Cond/TDS, RES sensor with SPECIAL Platinum RTD added or 1000Ω RTD temperature sensor. Connections - 3 (3 wire for increased accuracy over long distances)

**Calibration**

- Zero and Full Scale, FS (0 & 5VDC): Factory Set Simple pots
- Display (CAL): Full Scale, FS (199.9) Factory Set Simple pot
- Operates on safe ±5VDC supplied by the Main CB.

**2. INSTALLATION**

Briefly -

The Temperature Module replaces the plastic display retainer plate attached to the front panel.

The display harness plugs into the Temperature Module instead of the display.

The -TP sensor leads are connected to the Temperature Module. See figure III.C.1.

The display switch is installed in the upper front panel as shown in figure III.C.4.

A "TEMPERATURE" label is added to upper front panel next to the Display Select switch as shown in figure III.C.4.



**CAUTION - READ FOLLOWING CAREFULLY**

**WARNING: BEFORE STARTING, IF MONITOR/CONTROLLER IS INSTALLED, ENSURE THE POWER IS OFF. FAILURE TO DO SO COULD CAUSE DAMAGE TO THE INSTRUMENT, AND COULD BE HARMFUL OR FATAL TO PERSONNEL. ONLY QUALIFIED PERSONNEL SHOULD INSTALL OR SERVICE ELECTRICAL EQUIPMENT.**

**Physical**

If the front panel has all ready been removed from the enclosure skip to 3.

1. Using a standard slot screwdriver remove the four (4) screws on the front panel.
2. Carefully wiggle the front panel to loosen and pull gently toward you. Do not pull more than about 8 inches/20CM or you could damage the wiring harness.
3. Turn the front panel around so that the back side is facing you.
4. Using a standard slot screwdriver remove the four (4) screws holding the plastic display retainer plate to the front panel. When the screws have been removed, the plastic display retainer plate and the display will be free from the front panel.

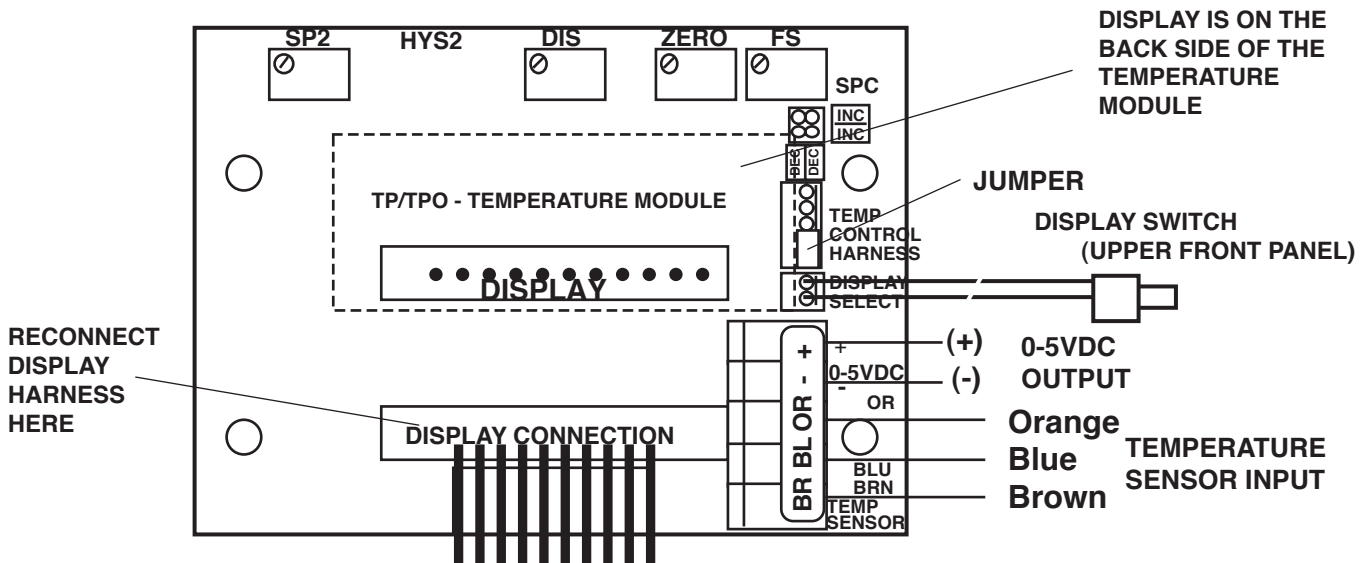
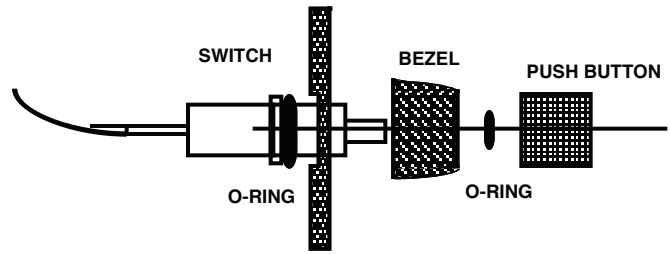


Figure III.C.1

- Set front panel down or carefully allow to hang from the harness. Do not drop as the harness connector will pull out allowing the front panel to fall.
- While holding the display and the plastic display retainer plate, carefully remove the display harness connector. Do not drop the display.
- Remove and discard the plastic display retainer plate.
- Insert display connector pins into the Temperature Module female connector. See figure III.C.1.
- While holding the front panel, align the display to the opening and at the same time, align the Temperature Module mounting holes to the front panel.
- Reconnect display harness with leads down as shown in figures III.C.1 & III.C.2.
- Reinstall the four (4) screws and tighten.



FRONT PANEL  
**SWITCH and O-RING ASSEMBLY**

**Figure III.C.3**

**Display Select Switch installation**

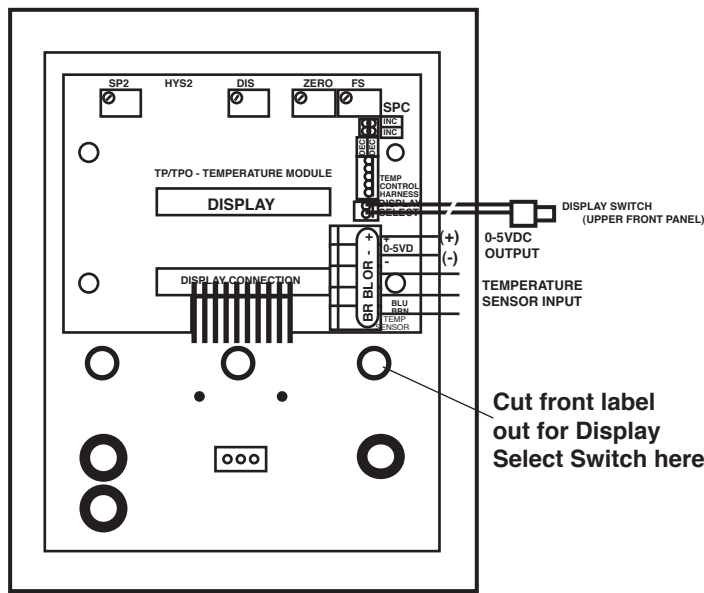
- Using a small sharp knife or 1/4" (6.35mm) drill, carefully cut open the hole on the right side of the front panel, when viewed from the back, just below the Sensor connectors on the Temperature module. See figure III.C.2.
- Install push-button display switch into this hole and tighten bezel. See figures III.C.2 & III.C.4.
- Install push-button/cap on switch.

**WARNING:** There are two (2) O-rings installed on the switch, one (1) on the threaded shank and the other is under the push button. Both of these must be re-installed to maintain IP64/NEMA 3 ratings. See figure III.C.3.

- Place "TEMPERATURE" label next to the switch. See figure III.C.4.

screwdriver or a pen to push on the release levers. The release levers may be broken or damaged if not pushed straight toward the CB. DO NOT push the release levers sideways. Follow the color code as labeled.

- Connect 0-5VDC output, if desired.
- To test, turn power **ON**.
- Press "TEMPERATURE" front panel switch, display will show the temperature of the sensor.
- Turn power **OFF**.
- Continue or reinstall the front panel and tightly secure both retaining screws, see REASSEMBLY below.



**FRONT PANEL**  
 Rear View

**Figure III.C.2**

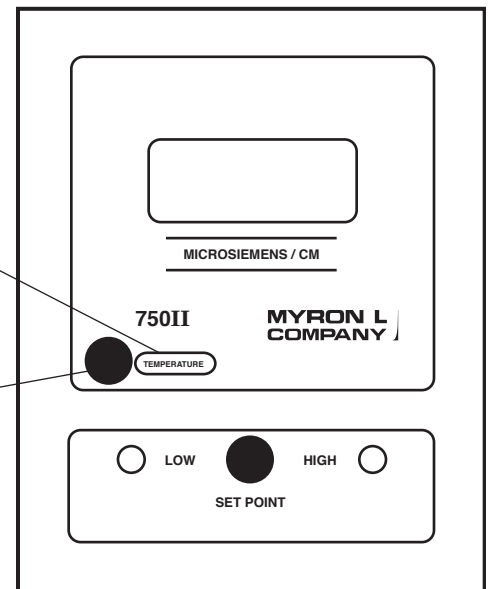
**Electrical**

- Connect the display switch harness to the Temperature Module as shown in figure III.C.1.
- Connect the Temperature Sensor leads to the Temperature Module as labeled in figure III.C.1.

**CAUTION:** The sensor input connectors require only a small

**TEMPERATURE Label Location**

**TEMPERATURE Switch Location**



**FRONT PANEL**

**Figure III.C.4**

**3. RECALIBRATION**

Electronic Calibration Only. For System Calibration, see below. The Temperature Module was calibrated at the factory, however, if you wish to check the calibration the following procedure will help you to accomplish this task. Exercise caution while performing this procedure.

Requirements:

- TP Calibration Module (TPC) or
- Two .1% precision resistors -
  - ZERO - 1000.0Ω (0°C = 0.0V)
  - SPAN - 1758.56Ω (200°C = 5.0V)
- One (1) jumper

A DVM set to DC Volts, a tweaker or small standard slot screwdriver.

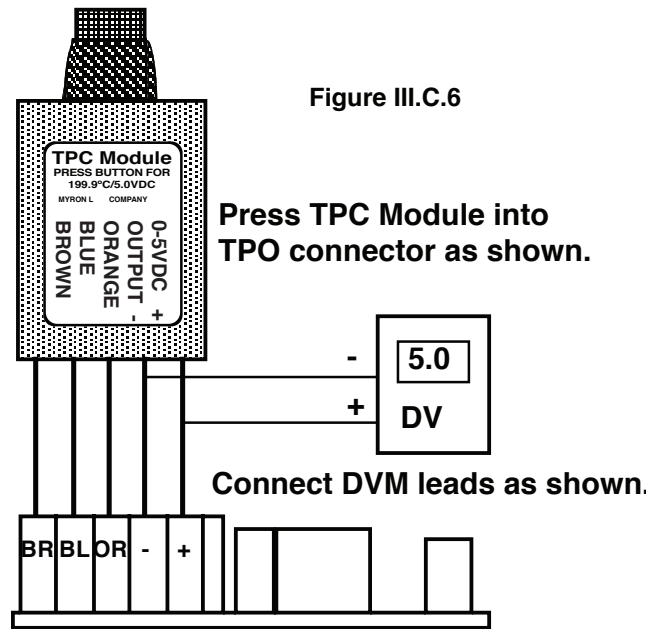
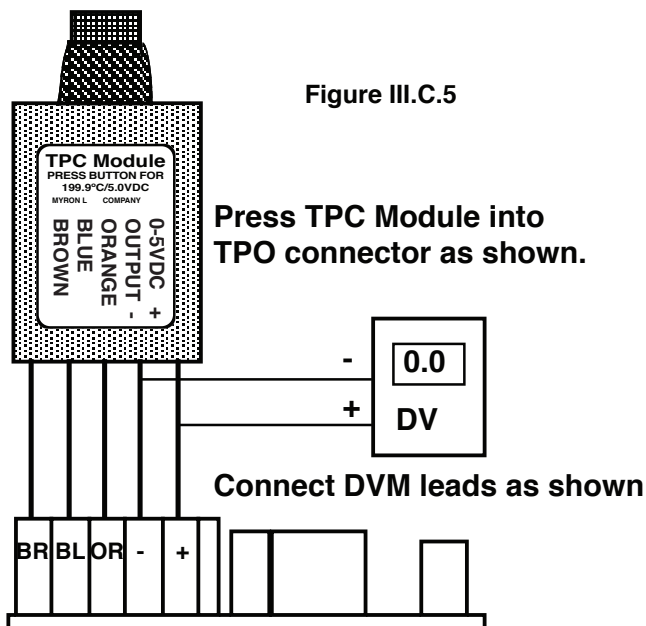


### a. TPC "Calibration" Module Procedure

This procedure assumes the front panel is removed.

1. Ensure power is **OFF**.
2. Remove the sensor leads from the Temperature Module.
3. Remove the 0-5VDC leads from the Temperature Module.
4. Press TP Calibration Module (TPC) **firmly** into sensor input connectors as shown in figure III.C.5.
5. Attach the DVM to the 0-5VDC output on the TPC module. See figure III.C.5.
6. Turn power **ON**. The DVM should indicate **0.0** volts.
7. If not, adjust the calibration control marked "**ZERO**" (see figure III.C.1 for location) until the DVM indicates **0.0** volts as shown in figure III.C.5.
8. Press switch on the TPC. See figure III.C.6.
9. The DVM should indicate **5.0** volts. See figure III.C.6.
10. If not, while pressing the TPC Module switch, adjust the calibration control marked "**FS**" (see figure III.C.1 for location) until the DVM indicates **5.0** volts as shown in figure III.C.6.
11. Press the front panel TEMPERATURE select switch **and** the TPC Module switch, the display should indicate **199.9** as shown in figure III.C.7.
12. If not adjust the calibration control marked "**DIS**" (see figure III.C.1 for location) until the reading is **199.9** as shown in figure III.C.7.
13. Calibration is complete.
14. Turn power **OFF**.
15. Remove TPC Module by pressing on each Phoenix connector release lever\*.
16. Reconnect sensor leads as labeled.
17. Reconnect 0-5VDC output leads as labeled.
18. Continue or reinstall the front panel and tightly secure four (4) retaining screws, see REASSEMBLY below.

**\*CAUTION:** The sensor input and 0-10VDC output connectors require only a small screwdriver or a pen to push on the release levers. The release levers may be broken or damaged if not pushed straight toward the CB. DO NOT push the release levers sideways.



**Figure III.C.7**

### b. Precision Resistor Calibration Procedure

This procedure assumes the front panel is removed.

1. Ensure power is **OFF**.
2. Remove the sensor leads from the Temperature Module.
3. Install ZERO resistor (1000.0Ω) across sensor terminals BL and OR. See figure III.C.8.
4. Install JUMPER between BR & BL as shown in figures III.C.8 & III.C.9.
5. Attach the DVM to the 0-5VDC output. See figures III.C.8 & III.C.9.
6. Turn power **ON**. The DVM should indicate **0.0** volts.
7. If not, adjust the calibration control marked "**ZERO**" (see figure III.C.1 for location).
8. Install SPAN resistor (1758.56Ω) across sensor terminals BL and OR. See figure III.C.9.
9. The DVM should indicate **5.0** volts.
10. If not, adjust the calibration control marked "**FS**" (see figure III.C.1 for location) until the DVM indicates **5.0** volts as shown in figure III.C.9.
11. Press the front panel TEMPERATURE select switch, the display should indicate **199.9** as shown in figure III.C.10.
12. If not adjust the calibration control marked "**DIS**" (see figure III.C.1 for location) until the reading is **199.9**.
13. Calibration is complete.
14. Turn power **OFF**.
15. Remove DVM from 0-5VDC.
16. Remove resistor and jumper by pressing on each Phoenix connector release lever\*.
17. Reconnect sensor leads as labeled.
18. Reconnect 0-5VDC output leads as labeled.

- Continue or reinstall the front panel and tightly secure four (4) retaining screws, see REASSEMBLY below.

**\*CAUTION:** The sensor input and 0-5VDC output connectors require only a small screwdriver or a pen to push on the release levers. The release levers may be broken or damaged if not pushed straight toward the CB. DO NOT push the release levers sideways.

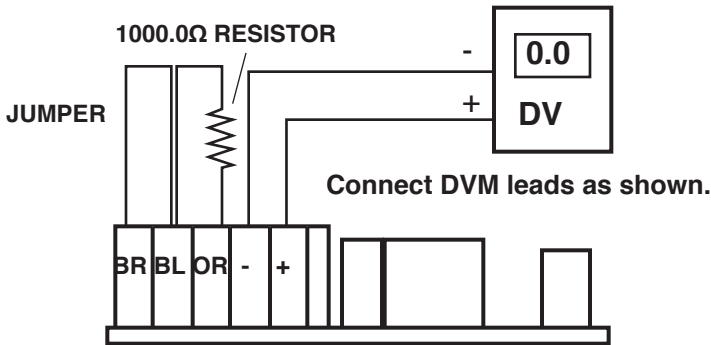


Figure III.C.8

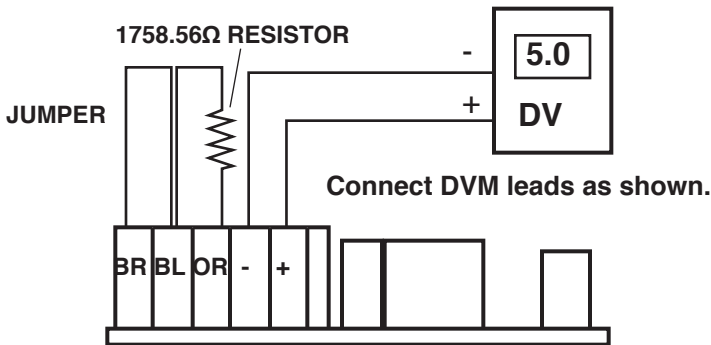


Figure III.C.9



FRONT PANEL DISPLAY

Figure III.C.10

#### c. System Calibration

By following these steps the complete temperature system, module and sensor, may be calibrated to better than  $\pm 0.2^\circ$  Centigrade accuracy. This procedure is similar to the electronic calibration except the sensor is attached and is allowed to equilibrate in "ICE" water before adjusting the ZERO calibration control.

**NOTE:** One of the above electronic calibration procedures, TPC Module or precision resistors, must be performed BEFORE the system calibration is performed. This is required to preset the span between zero and full scale.

- Ice must be crushed in water to form a very thick slurry. A slurry is that condition where the water to ice ratio is such that only sufficient water is present to allow easy stirring. At this point, the temperature of the water will be  $0.000^\circ\text{C}$ .
- Immerse sensor and cable approximately 2in./50mm

into slurry.

- Allow to equilibrate. Slurry must be constantly stirred.
- Continue stirring until no further change in temperature is observed on the display.
- Adjust TP Module ZERO calibration control to 000.0.
- Continue or reinstall the front panel and tightly secure four (4) retaining screws, see REASSEMBLY below.

#### 4. ALARM/CONTROL FUNCTION

You have now completed the installation and set up of your Myron L Temperature Module option. Continue to set up and adjust the control feature of the Temperature Module option (-TH/THO & -SC/SCO), if installed.

The following assumes the TH/THO option has been installed at the same time as the Temperature Module.

##### a. Set Point Conversion (SPC) / Reversing Set Point

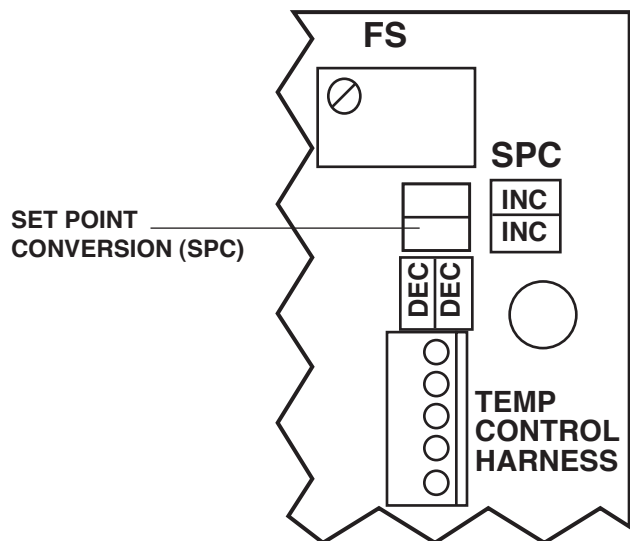
As shipped from the Myron L Company your Temperature controller is configured to ALARM/control when the temperature is to TOO HIGH. As many uses require the temperature to be controlled by the use of a heater or chiller, the TPO Module may be configured to maintain an elevated or lowered temperature as required. If the configuration is correct for your requirements skip to Temperature Set Point Adjust.

To reverse the set point ALARM/control operation:

- Ensure power is OFF.
- Locate the SPC on TP/TPO circuit board. See figures III.C.1 & III.C.11.
- Make a note of the current orientation of the SPC jumpers.
- Remove both jumpers. This is easily done by hand. Take care not to crush the jumpers if using pliers.
- Rotate the jumpers  $1/4$  turn ( $90^\circ$ ) and reinstall them on their posts as shown in figure III.C.12.
- Continue with Set Point adjustment.

##### b. Temperature Set Point Adjust

- Ensure power OFF.
- Ensure the SCO Module Set Point control is set to FULL



DETAIL OF SET POINT CONVERSION (SPC) ON TP/TPO MODULE AS CONFIGURED WHEN SHIPPED FROM THE MFR.

Figure III.C.11

counterclockwise position. If not, turn SCO Set Point control fully CCW - it may be 30 turns - or until it clicks. For location see figure III.C.13.

3. Turn power **ON**.
4. Press BOTH the Temperature Select switch and the Set Point switch on the front panel.
5. Adjust the TP/TPO Module Set Point Two (SP2) to temperature as desired. See figure III.C.1.
6. Turn power **OFF**.

c. **Hysteresis** is fixed at approximately  $\pm 6^{\circ}\text{C}$  unless Special Ordered with adjustable control. Hysteresis with adjustable control is variable from  $\pm 0.6$  to  $6^{\circ}\text{C}$ , see figure III.C.1 for location.

**CAUTION:** Adjusting the hysteresis too narrow may cause the alarm to fluctuate (on-off) due to temperature variations causing the relay to chatter. This condition is to be avoided, it may damage the heater, chiller, etc. and will eventually damage the relay.

#### REASSEMBLY

1. Carefully reinstall the front panel, bottom first. Ensure no wires have been pinched between enclosure and front panel.
2. Reinstall the four (4) screws and tighten.
3. To operate, turn power **ON**.

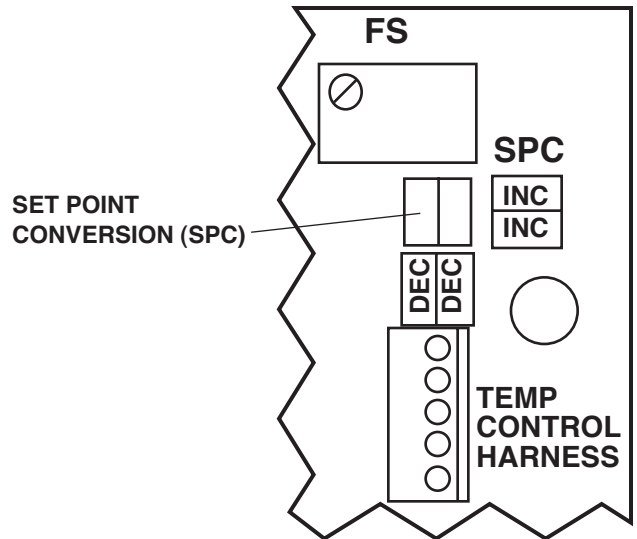


Figure III.C.12

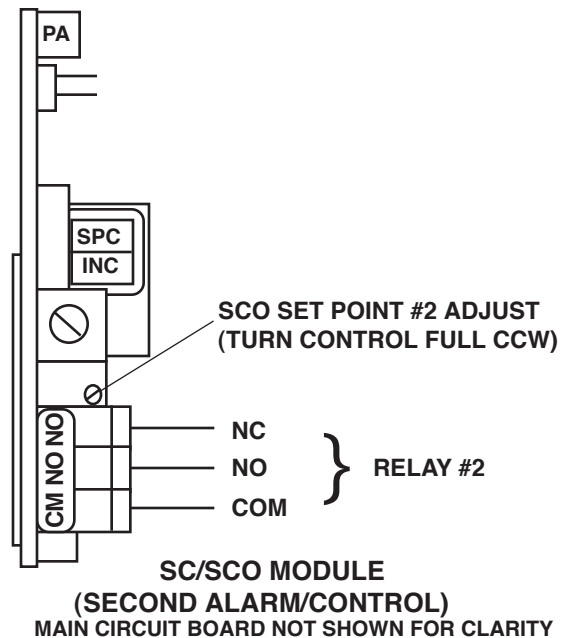


Figure III.C.13

**5. OEM INSTALLATION**

**a. Single Display Models**

An OEM installation requires an additional display harness, part number TPMH. This harness is installed between the Temperature Module and the panel display as shown in figure III.C.14. Both connectors must be installed with the wires down or toward the bottom of the circuit board.

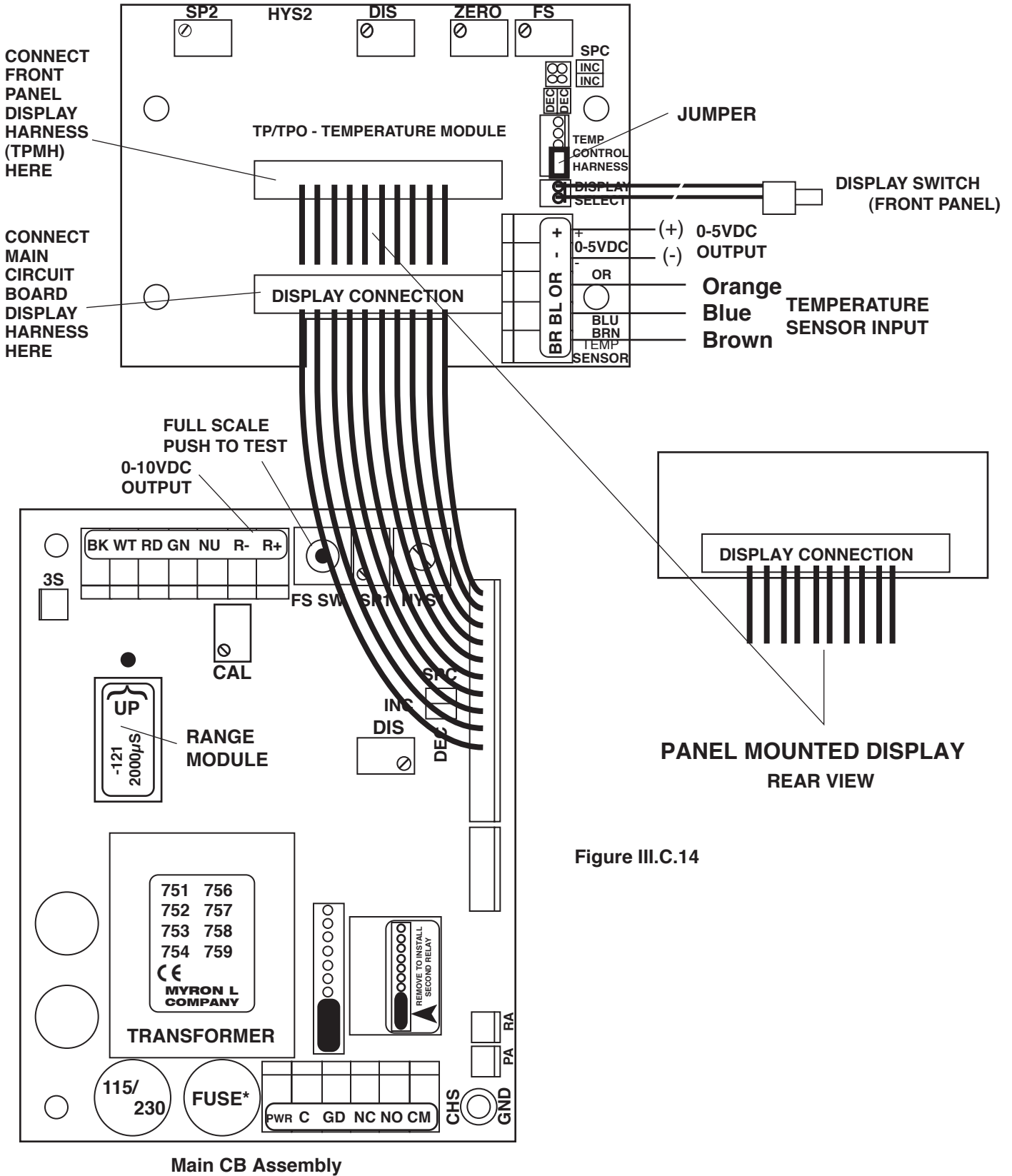
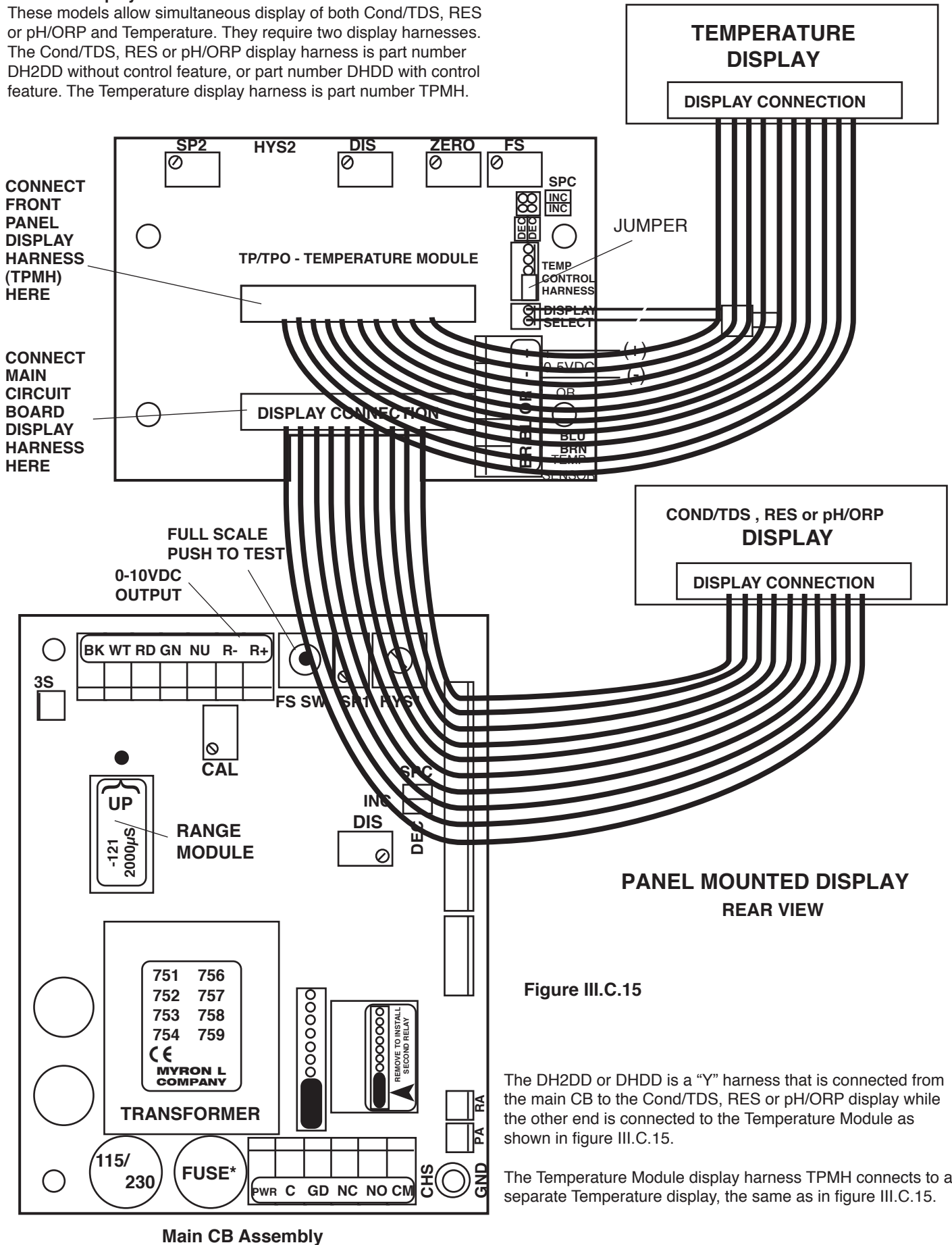


Figure III.C.14

**6. OEM INSTALLATION**

**b. Dual Display Models SPECIAL ORDER**

These models allow simultaneous display of both Cond/TDS, RES or pH/ORP and Temperature. They require two display harnesses. The Cond/TDS, RES or pH/ORP display harness is part number DH2DD without control feature, or part number DHDD with control feature. The Temperature display harness is part number TPMH.



The DH2DD or DHDD is a "Y" harness that is connected from the main CB to the Cond/TDS, RES or pH/ORP display while the other end is connected to the Temperature Module as shown in figure III.C.15.

The Temperature Module display harness TPMH connects to a separate Temperature display, the same as in figure III.C.15.

**D. ALARM/CONTROL KIT**

(Digital & OEM Models only)

- TH Controller wiring Harness (requires second alarm/control module) ordered with Monitor/controller.
- THO Controller wiring Harness (requires second alarm/control module) ordered separately.

**1. DESCRIPTION**

The optional TH/THO Controller Kit adds more flexibility to the Temperature Module by adding the ability to Alarm and/or Control using the 24VDC solid state output to drive a PA - Piezo electric alarm, and/or a 10 amp relay to operate a heater or chiller as required.

**Kit includes**

THO kit comes with all items necessary to install and operate: Alarm/control Harness (replaces second alarm/control relay harness) with switch, bezel, cap and two O-rings (006 & 008); and TEMPERATURE label (# LTEMP).

**Requirements**

- SC/SCO Alarm/Control Module (#2 set point/relay) option
- TP/TPO Temperature Module option

The TH/THO uses SC/SCO Second alarm/control Module on Main circuit board [Conductivity/TDS, Resistivity, pH or mV (ORP)].

**2. INSTALLATION**

Briefly -

The SCH (switch and LED) harness is removed from the SC and front panel, and discarded.

The THO harness is installed to the SC, TPO or other control-able option, and front panel.

A label is installed on the front panel.



**CAUTION - READ FOLLOWING CAREFULLY**

**WARNING: BEFORE STARTING, IF MONITOR/CONTROLLER IS INSTALLED, ENSURE THE POWER IS OFF. FAILURE TO DO SO COULD CAUSE DAMAGE TO THE INSTRUMENT, AND COULD BE HARMFUL OR FATAL TO PERSONNEL. ONLY QUALIFIED PERSONNEL SHOULD INSTALL OR SERVICE ELECTRICAL EQUIPMENT.**

**Physical**

First, you must decide which location to install the THO harness LED and Set Point switch. This is easily determined by how the Primary or the Main CB Alarm/control is used. If the Primary Alarm/control is used as a **HIGH** control, as in Conductivity, than the THO harness is installed in the lower location - see section III.D.2.a below.

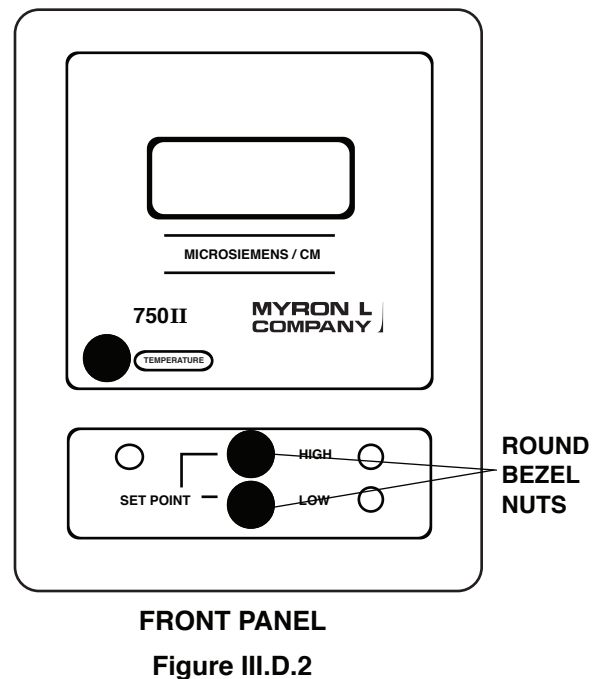
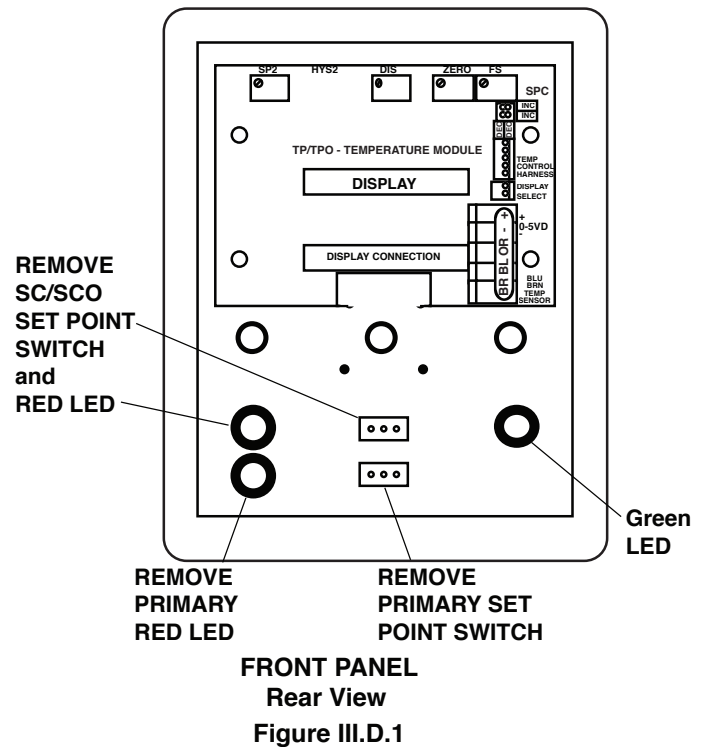
If your Primary or Main circuit board Alarm/control is used as a **LOW** control, as in Resistivity, than the THO harness is installed in the HIGH location — see section III.D.2.b below.

**WARNING:** Before installing switch keep in mind there are two (2) O-rings installed on each switch, one (1) on the threaded shank and the other is under the push button. Both of these must be reinstalled properly to maintain IP64/NEMA 3 ratings, see figure III.D.4.

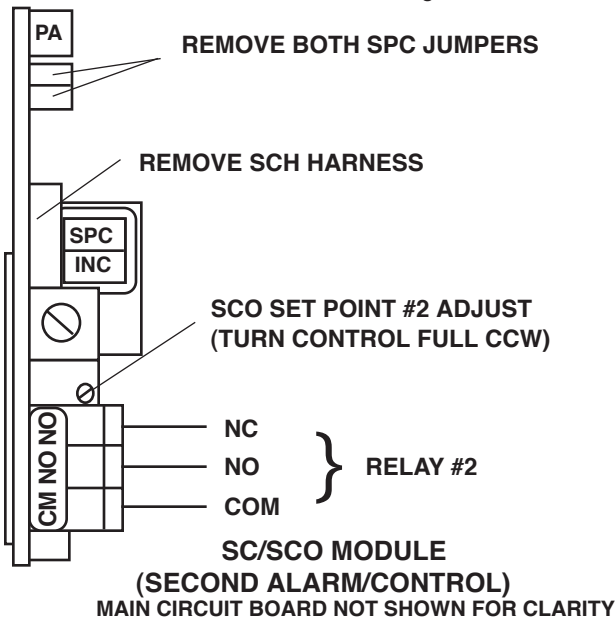
**a. HIGH Primary Control**

If the front panel has all ready been removed from the enclosure skip to step 3.

1. Using a standard slot screwdriver remove the four (4) screws on the front panel.
2. Carefully wiggle the front panel to loosen the and pull gently toward you. Do not pull more than about 8 inches/20CM or you could damage the wiring harness.
3. Remove SCH harness from front panel and SC/SCO Second Alarm/Control Module.
  - a. Carefully remove the RED LED from the front panel



- by pulling lightly on the wires. It may be necessary to use a small flat screwdriver to slightly spread the retaining ring. See figure III.D.1.
- b. Remove Set Point Switch from the front panel, figure III.D.1, by rotating the round bezel nut CCW on the front as shown in figure III.D.2.
  - c. Remove SCH harness from SC Module by on pulling harness.
  - d. Set SCH harness aside, it is no longer used.
4. Remove Primary or Main CB alarm/control LED and Set Point Switch from lower location on front panel.
    - a. Carefully remove the RED LED from the front panel by pulling lightly on the wires. It may be necessary to use a small flat screwdriver to slightly spread the retaining ring. See figure III.D.1.
    - b. Remove Set Point Switch from the front panel, figure III.D.1, by rotating the round bezel nut CCW on the front as shown in figure III.D.2.

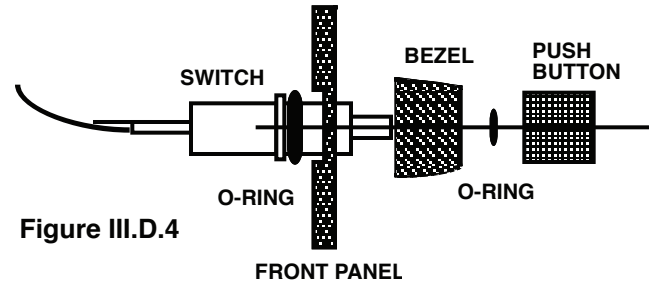


**Figure III.D.3**

5. Re-install Primary or Main CB alarm/control LED and Set Point Switch into UPPER location as shown in figure III.D.6.
6. Install TH/THO harness to front panel. See figure III.D.6.
  - a. Install Set Point Switch into the LOWER CENTER switch location.
  - b. Press RED LED into the LOWER location.
7. Remove SPC jumpers (2) from SC/SCO Second Alarm/Control Module, see figure III.D.3 for SPC jumper location.
8. Install TH/THO harness to SC/SCO Second Alarm/Control Module.
  - a. Attach BLACK 90° connector with four (4) wires to SPC location with the connector 90° to the SC as shown in figures III.D.7 & III.D.8.
  - b. Press WHITE connector with two wires and one jumper into the SC - it is directional, as shown in figures III.D.7 & III.D.8.
9. Turn SCO Set Point control fully counter clockwise - it may be 30 turns - or until it clicks. See figure III.D.7 for location.
10. The GREEN LED stays in the same location.

11. Locate and remove JUMPER from the Temperature (TPO) Module as shown in figure III.D.5.
12. Attach Brown 5 wire connector to the TPO Module as shown in figure III.D.9.
13. Add TEMPERATURE label to LOWER front panel covering the "LOW" as shown in figure III.D.10.
14. Attach control leads to RELAY #2 as shown in figure III.D.3.
15. Continue to Set Point Conversion or skip to "SPECIFIC OPTION" Module Set Point adjust.

**WARNING:** There are two (2) O-rings installed on the switch, one (1) on the threaded shank and the other is under the push button. Both of these must be reinstalled to maintain IP64/NEMA 3 ratings. See figure III.D.4.



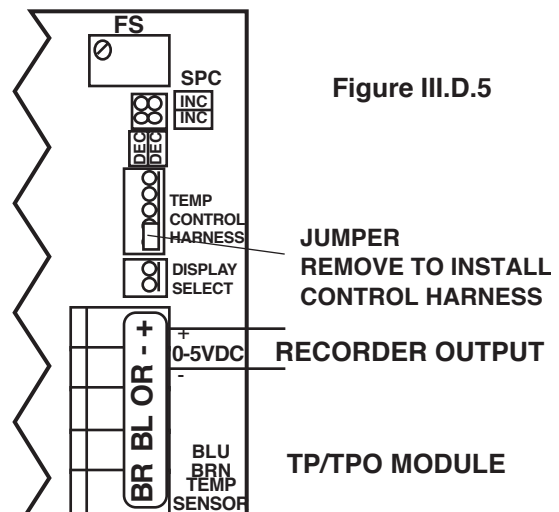
**Figure III.D.4**

**FRONT PANEL  
SWITCH and O-RING ASSEMBLY**

**b. LOW Primary Control**

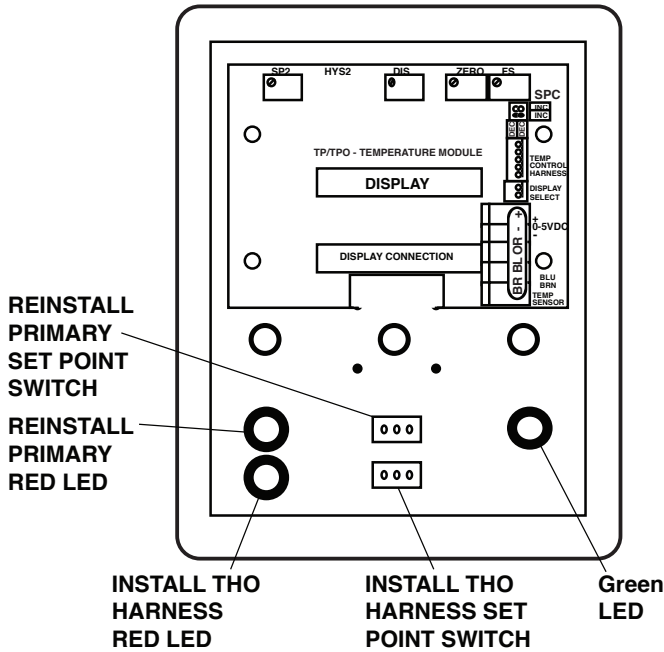
If the front panel has all ready been removed from the enclosure skip to step 3.

1. Using a standard slot screwdriver remove the four (4) screws on the front panel.
2. Carefully wiggle the front panel to loosen and pull gently toward you. Do not pull more than about 8 inches/20CM or you could damage the wiring harness.
3. Remove SCH harness from front panel, figure III.D.11, and SC/SCO Second Alarm/Control Module, figure III.D.3 for locations.
  - a. Carefully remove the UPPER RED LED from the front panel by pulling lightly on the wires. It may be necessary to use a small flat screwdriver to slightly spread the retaining ring. See figure III.D.1.
  - b. Remove UPPER Set Point Switch from the front panel by rotating the round bezel nut CCW on the front as shown in figure III.D.2.



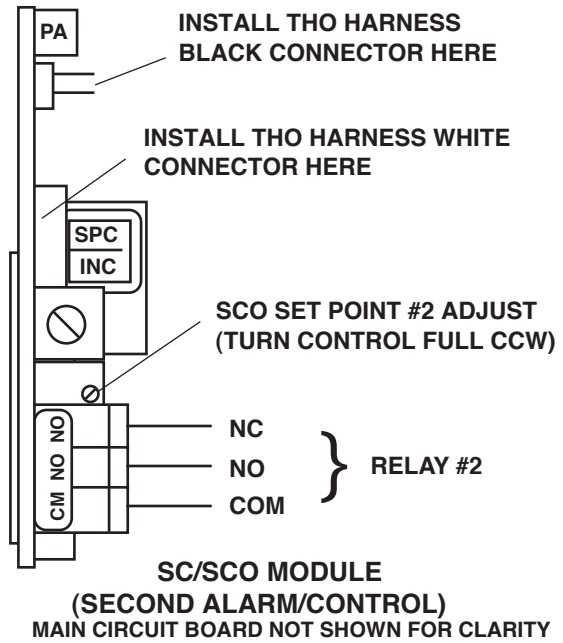
**Figure III.D.5**

- c. Remove harness from SCO Module by pulling on harness, see figure III.D.3.
- d. Set SCH harness aside, it is no longer used.
- 4. Remove SPC jumpers (2) from SC/SCO Second Alarm/Control Module, see figure III.D.3 for SPC jumper location.



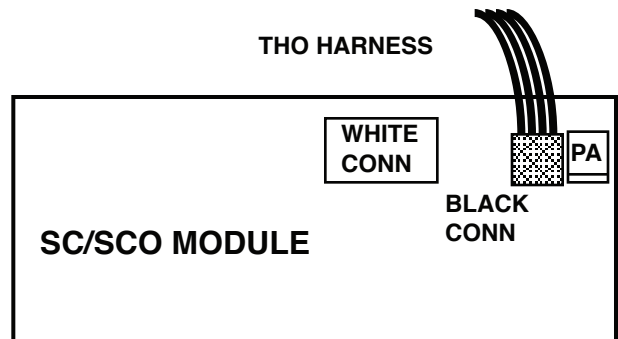
**Figure III.D.6**  
**FRONT PANEL**  
**Rear View**

- 5. Install TH/THO harness to front panel, figures III.D.12 & III.D.13.
  - a. Install THO Set Point Switch to the UPPER CENTER switch location, figure III.D.12, keeping in mind the "O-ring" warning above. See figure III.D.4 for switch reassembly.
  - b. Press RED LED into the UPPER location, as shown in figure III.D.12.
- 6. Install TH/THO harness to SC/SCO, figures III.D.7 & III.D.8.

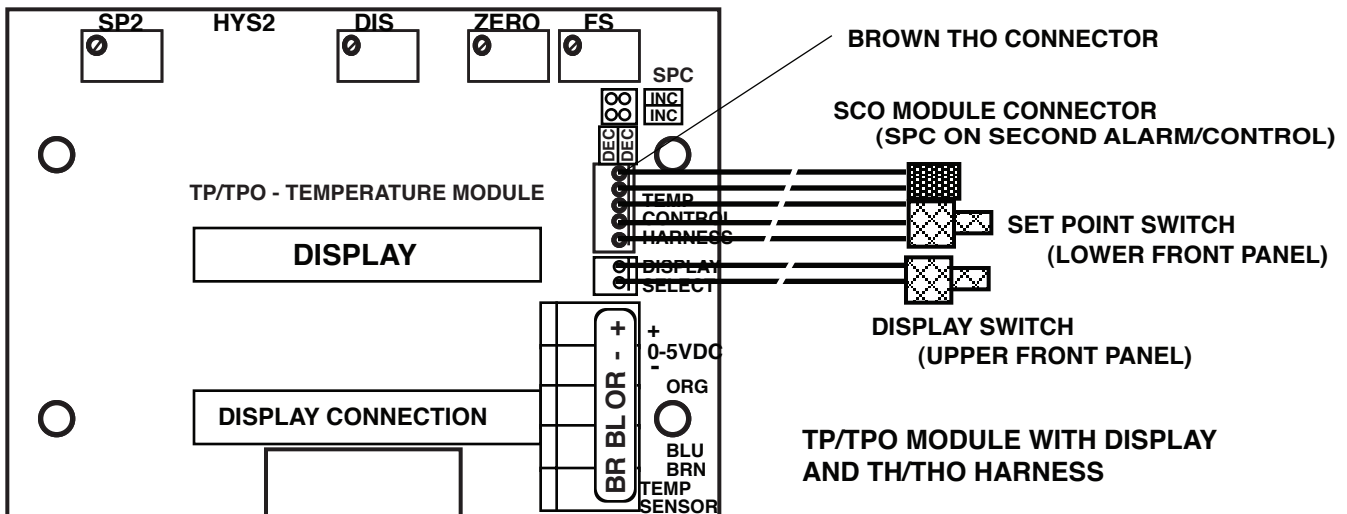


**Figure III.D.7**

- a. Attach BLACK 90° connector with four (4) wires to SPC location with the connector 90° to the SCO as shown in figures III.D.7 & III.D.8.
- b. Press WHITE connector with two wires and one jumper into the SCO - it is directional, as shown in figures III.D.7 & III.D.8.
- 7. The GREEN LED stays in the same location.

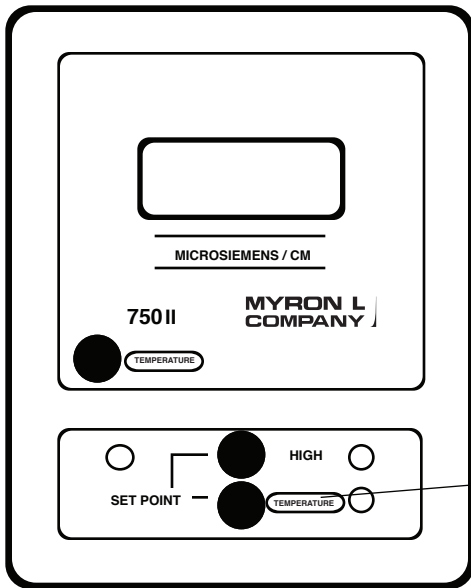


**Figure III.D.8**



**Figure III.D.9**

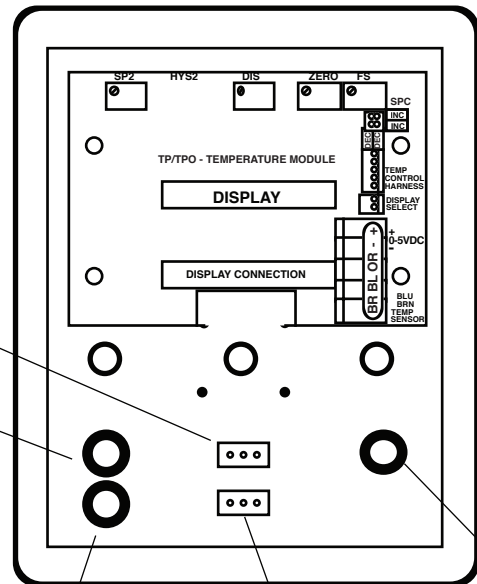




**FRONT PANEL**

**Figure III.D.10**

**TEMPERATURE LABEL LOCATION**



**PRIMARY RED LED**

**PRIMARY SET POINT SWITCH**

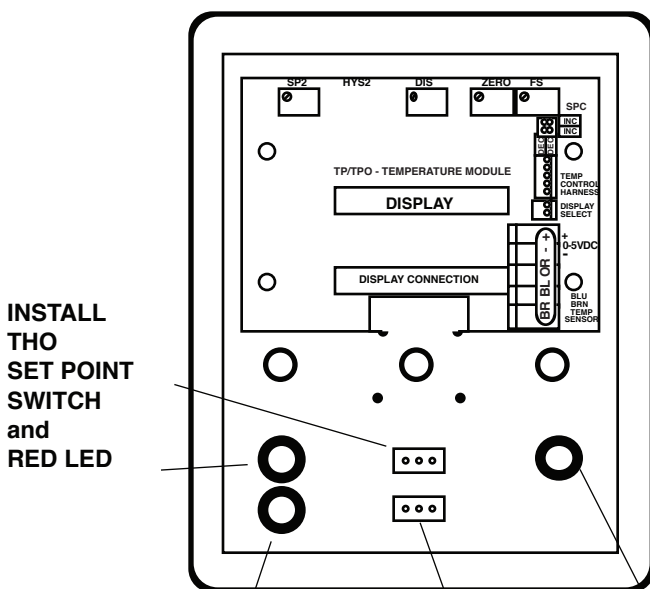
**Green LED**

**FRONT PANEL  
Rear View**

**Figure III.D.11**

8. Turn SCO Set Point control fully counter clockwise — it may be 30 turns - until it clicks. See figure III.D.7 for location.
9. Locate and remove JUMPER from option to the TPO Module as shown in figure III.D.5.
10. Attach Brown 5 wire connector to option to be controlled, i.e. TPO Module as shown in figure III.D.9.

11. Add TEMPERATURE label to UPPER front panel covering the "HIGH" as shown in figure III.D.13.
12. Attach control leads to RELAY #2 as shown in figure III.D.7.
13. Continue to Set Point Conversion or skip to "SPECIFIC OPTION" Module Set Point adjust.



**INSTALL THO SET POINT SWITCH and RED LED**

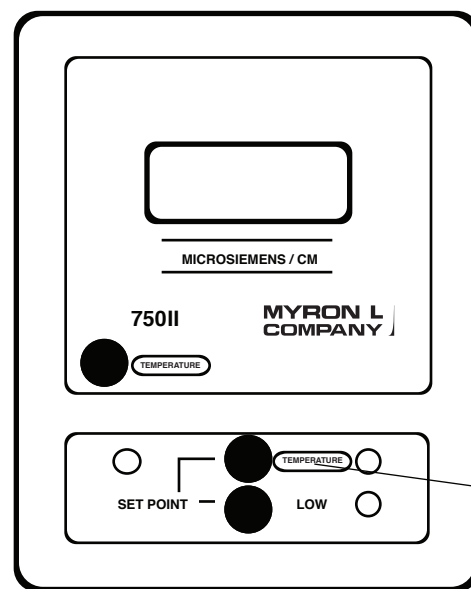
**Primary/Main CB Red LED**

**Primary/Main CB Set Point Switch**

**Green LED**

**FRONT PANEL  
Rear View**

**Figure III.D.12**



**TEMPERATURE LABEL LOCATION**

**FRONT PANEL**

**Figure III.D.13**

### Set Point Conversion (SPC) / Reversing Set Point

The Myron L Company ships the Temperature controller configured to Alarm/control when the temperature is TOO HIGH. If the configuration is correct for your requirements skip to Temperature Set Point Adjust.

As many uses require the temperature to be controlled by the use of a heater or chiller, the TPO Module may be configured to maintain an elevated or lowered temperature as required.

To reverse the set point/relay operation:

1. Locate the SPC on TP/TPO circuit board. See figures III.D.8 & III.D.14.
2. Remove Jumpers.
3. Reinstall Jumpers 90° as shown in figure III.D.15.

### FOR TEMPERATURE MODULE

#### Temperature Set Point Adjust

1. Ensure the SCO Module Set Point control is set to FULL CCW position. For location see figure III.D.6.
2. Press BOTH the Temperature Select switch and the Set Point switch on the front panel.
3. Adjust the TP/TPO Module Set Point Two (SP2) to temperature as desired. See figure III.D.8.

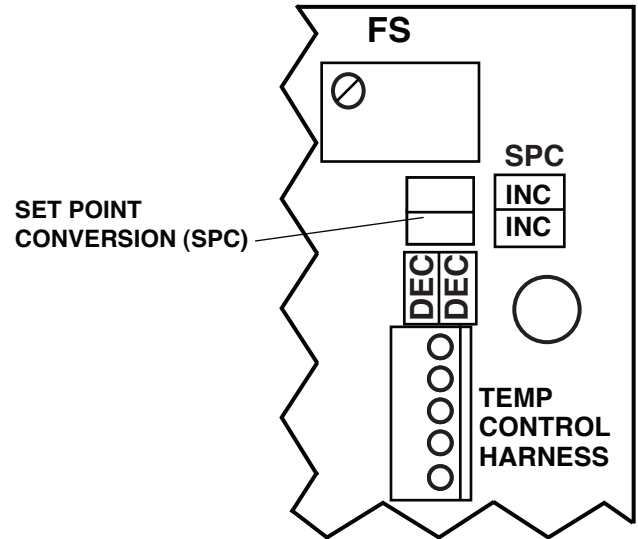
**Hysteresis** is fixed at  $\sim\pm 6^{\circ}\text{C}$  unless Special Ordered with adjustable control.

Hysteresis with adjustable control is variable from  $\pm 0.6$  to  $6^{\circ}\text{C}$ .

**CAUTION:** Adjusting the hysteresis too narrow may cause the alarm to fluctuate (on-off) due to temperature variations causing the relay to chatter. This condition is to be avoided, it may damage the heater, chiller, etc. and will eventually damage the relay.

### REASSEMBLY

1. Carefully reinstall the front panel, bottom first. Ensure no wires have been pinched between enclosure and front panel.
2. Reinstall the four (4) screws and tighten.
3. To operate, turn power **ON**.



DETAIL OF SET POINT CONVERSION (SPC) ON TP/TPO MODULE AS CONFIGURED WHEN SHIPPED FROM THE MFR.

Figure III.D.14

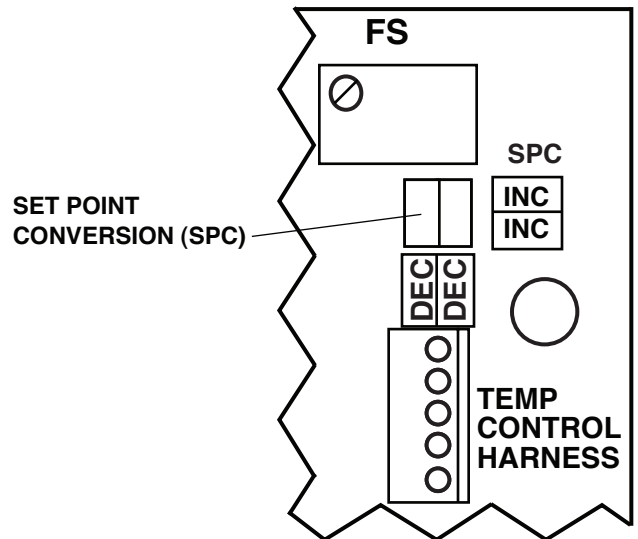


Figure III.D.15

**E. INSTALLATION OF BOTH TEMPERATURE MODULE & 4-20mA OUTPUT MODULE**  
(Digital and OEM Models ONLY)

-TP/TPO Temperature Module.  
-4A/4AO4-20mA Self/Remote-powered Isolated output module.

**1. DESCRIPTION**

The following instructions describe how to install BOTH the 4A/4AO and the TP/TPO Modules to a Digital model Monitor/controller.

**Specifications**

See individual Data Sheets and installation instructions.

Requires Plastic Spacers P# SP4819.

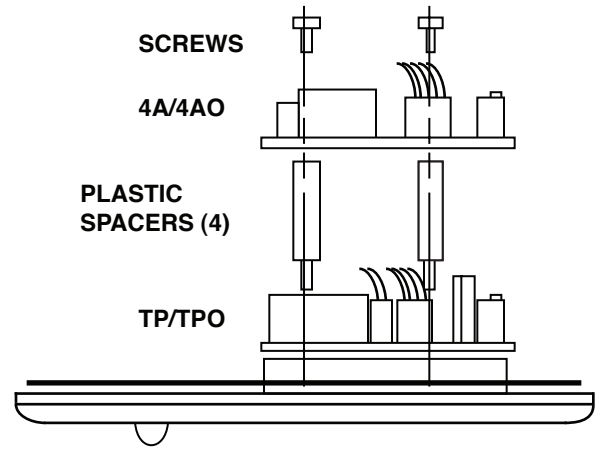
**2. INSTALLATION**

Briefly -

The Temperature Module replaces the plastic display retainer plate attached to the front panel as described in Temperature Module Installation Instructions except threaded plastic spacers are utilized in place of the screws.

The 4AO Module is STACKED on top of the TPO Module utilizing above spacers as shown in figure III.E.1.

Setup and operation for both modules is the same as described in their respective Data Sheet/Installation Instructions.



**FRONT PANEL  
LEFT SIDE VIEW**

**Figure III.E.1**



**CAUTION - READ FOLLOWING CAREFULLY**

**WARNING: BEFORE STARTING, IF MONITOR/CONTROLLER IS INSTALLED, ENSURE THE POWER IS OFF. FAILURE TO DO SO COULD CAUSE DAMAGE TO THE INSTRUMENT, AND COULD BE HARMFUL OR FATAL TO PERSONNEL. ONLY QUALIFIED PERSONNEL SHOULD INSTALL OR SERVICE ELECTRICAL EQUIPMENT.**

This procedure assumes the front panel is removed, and the TP/TPO has already been installed.

1. Install spacers as shown in figure III.E.1.
2. Attach 4AO Module five (5) wire harness, and signal and power wires as required as described in 4AO Data Sheet/Installation Instructions.
3. Carefully reinstall the front panel, bottom first. Ensure no wires have been pinched between enclosure and front panel.
4. Reinstall the four (4) screws and tighten.
5. To operate, turn power **ON**.

**F. 3 SENSOR INPUT MODULE**

- 3SO 3 Sensor Input Module with 3 foot / 1 meter cable ordered separately (customer installed and mounted).
- 3SE 3 Sensor Input Module with 3 foot / 1 meter cable AND separate Enclosure (as an accessory). Enclosure is the same size as the Monitor/controller - 4.8"W x 6"H x 3.9"D.

**1. DESCRIPTION**

3 Sensor Input Module is a circuit board (CB) with a 4 pole 3 position rotary switch, and 3 groups of 5 connectors where up to three sensors may be connected. This option allows the user to view 3 separate sensor locations and to set the alarm/control function using only one Monitor/controller. The setpoints will not change nor are they separately adjustable for each sensor.

As shipped from the factory, the number "1" sensor position is set to be the primary or the controlling sensor while the other sensor positions are monitoring ONLY. This feature disables or stops the alarm/control function from operating when changing sensors. In other words, while in the #2 or #3 position the alarm/controller is disabled. However, any of the sensor positions may be selected to control by resetting the SELECT SWITCHES as shown on the CB and described below. The 3S will function with all Conductivity/TDS and Resistivity models, analog or digital.

**Specifications**

NONE

**2. INSTALLATION**

Briefly -

The 3SO must be installed/mounted by user outside of the Monitor/controller housing by drilling a hole in user panel. For the 3SE, a cutout the size of the enclosure is required.

A five conductor cable is connected to the 3S Module CB. This cable is connected to the main Monitor/controller circuit board

(CB) at the sensor input connectors.

A separate small connector & harness is for the alarm/control disable or kill, and attaches to the small 2 pin male connector located to the left of the large sensor input connectors on the main CB. **NOT INSTALLED ON MONITOR ONLY MODELS.**



**CAUTION - READ FOLLOWING CAREFULLY**

**WARNING: BEFORE STARTING, IF MONITOR/CONTROLLER IS INSTALLED, ENSURE THE POWER IS OFF. FAILURE TO DO SO COULD CAUSE DAMAGE TO THE INSTRUMENT, AND COULD BE HARMFUL OR FATAL TO PERSONNEL. ONLY QUALIFIED PERSONNEL SHOULD INSTALL OR SERVICE ELECTRICAL EQUIPMENT.**

**Physical**

3SO Module only - A suitable location must be found that is both convenient to the user and allow sufficient clearance for the 3 Sensor Switch Module to clear obstructions. 3SE - 3 Sensor Switch Module with enclosure, a cutout the size of the enclosure is required. Install enclosure per Operation Manual, and skip to #4 below.

1. A 3/8" (9.5mm) hole must be drilled in the "user" panel. This hole must be situated in a location that allows the 3 Sensor Input Module to be mounted.
2. Install label, aligning on the drilled hole.

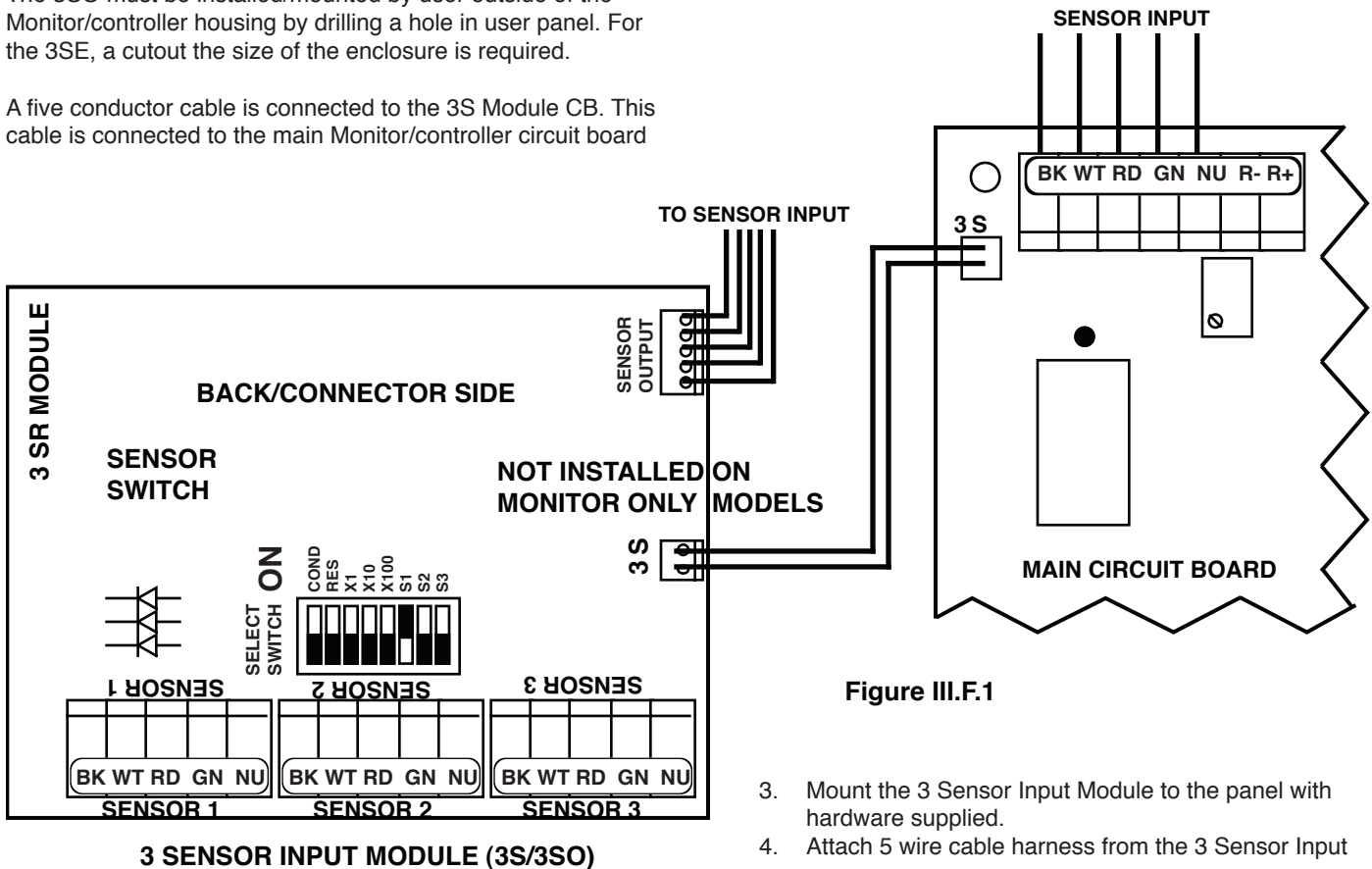


Figure III.F.1

3. Mount the 3 Sensor Input Module to the panel with hardware supplied.
4. Attach 5 wire cable harness from the 3 Sensor Input

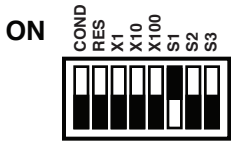


Figure III.F.2

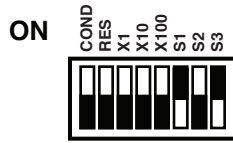


Figure III.F.3

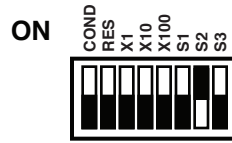


Figure III.F.4

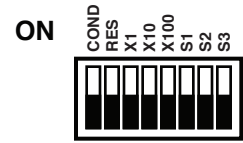


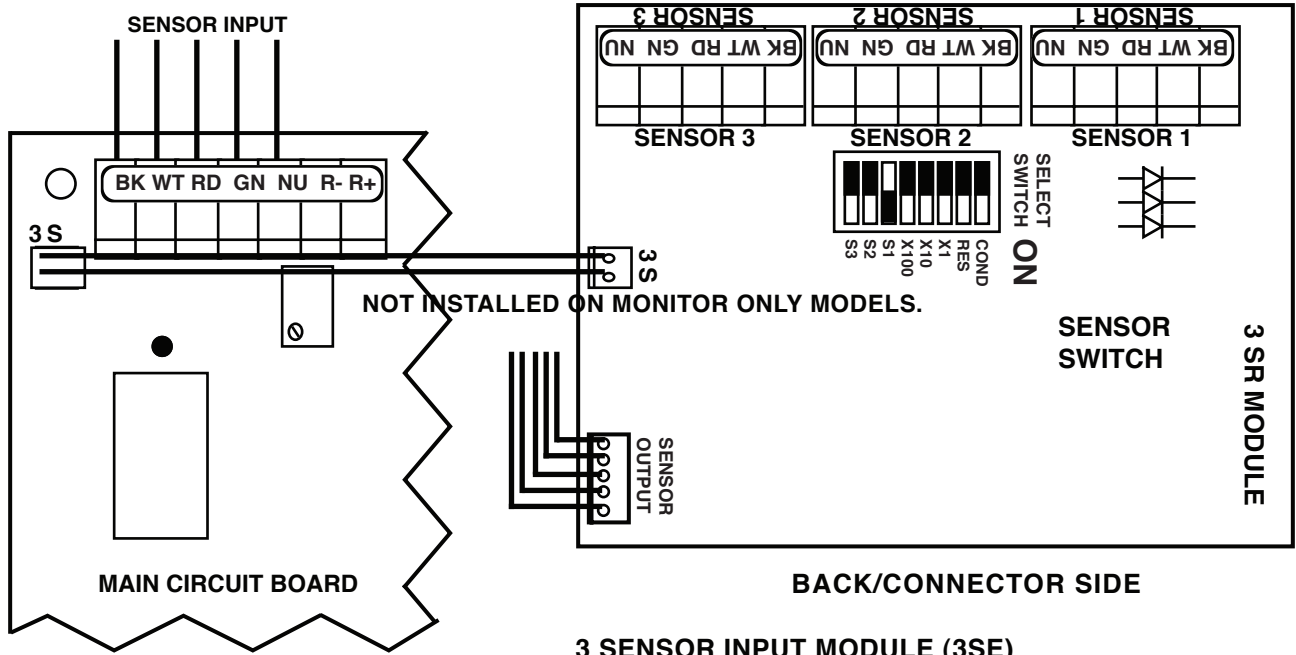
Figure III.F.5

### Factory Default

Module to the main Monitor/controller CB at the sensor input location as shown on label.

- Attach the separate small cable harness from the 3 Sensor Input Module to the small 2 pin male connector located to the left of the sensor input connectors on the main CB. **NOT INSTALLED ON MONITOR ONLY MODELS.**

only the Primary or First switch position SENSOR 1 is set to alarm/control as shown in figure 2, or figure 7 for 3SE. If your particular application requirements are different, the following will help you to reconfigure the alarm/control function to another sensor or add a controlling sensor. Pick the appropriate scenario below.



3 SENSOR INPUT MODULE (3SE)

Figure III.F.6

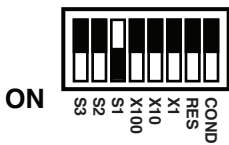


Figure III.F.7

Factory default



Figure III.F.8



Figure III.F.9

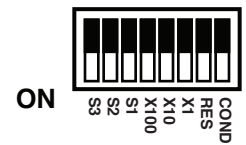


Figure III.F.10

### Sensor Connections

For convenience, it is recommended you connect the Primary or controlling sensor to SENSOR 1 position. See figures 1 or 6 for 3SE.

**CAUTION:** The sensor input connectors require only a small screwdriver or a pen to push on the release levers. Follow the color code as marked. The release levers may be broken or damaged if not pushed straight toward the CB. DO NOT push the release levers sideways.

### 3. ALARM/CONTROL CONFIGURATION

As shipped from the factory, the 3S Module is configured so that

**NOTE:** the setpoints will not change nor are they separately adjustable for each sensor.

### 3SO MODULE

If adding an alarm/control sensor.

- Locate the 8 position select switch on the 3S Module.
- Set appropriate select switch UP or ON, i.e. to add S3 sensor, set switch marked **S3** ON, see figure III.F.3.

If changing alarm/control from one sensor to another, i.e. S1 to S2 sensor.

- Locate the 8 position select switch on the 3S Module.
- Set the **S1** select switch in the DOWN or OFF position.
- Set the **S2** select switch in the UP or ON position, see

figure III.F.4.

To disable the Sensor alarm/control function completely.

1. Locate the 8 position select switch on the 3S Module.
2. Set all **S** prefixed select switches in the OFF position, see figure III.F.5.

### **3SE MODULE with ENCLOSURE**

If adding an alarm/control sensor.

1. Locate the 8 position select switch on the 3S Module.
2. Set appropriate select switch DOWN or ON, i.e. to add S3 sensor, set switch marked **S3** ON, see figure III.F.8.

If changing alarm/control from one sensor to another, i.e. S1 to S2 sensor.

1. Locate the 8 position select switch on the 3S Module.
2. Set the **S1** select switch in the UP or OFF position.
3. Set the **S2** select switch in the DOWN or ON position, see figure III.F.9.

To disable the Sensor alarm/control function completely.

1. Locate the 8 position select switch on the 3S Module.
2. Set all **S** prefixed select switches in the UP or OFF position, see figure III.F.10.

### **3SE REASSEMBLY**

1. Carefully reinstall the front panel, bottom first. Ensure no wires have been pinched between enclosure and front panel.
2. Reinstall the four (4) screws and tighten.
3. To operate, turn power **ON**.

## G. 3 RANGE SWITCH MODULE

- 3RO 3 Range Switch Module with 3 foot / 1 meter cable ordered separately (customer installed and mounted).
- 3RE3 Range Switch Module with 3 foot / 1 meter cable AND separate Enclosure (as an accessory). Enclosure is the same size as the Monitor/controller - 4.8"W x 6" H x 3.9"D.

### 1. DESCRIPTION

The 3 Range Switch Module (3RO or 3RE) is a circuit board (CB) with a 3 position rotary switch. This option allows the user to select which range to view, and to set for alarm/control function. The 3R may be configured - via select switches - to disable or stop the alarm/control function from operating when changing ranges. The 3R will function with all Conductivity/TDS and Resistivity models, analog or digital.

NOTE: the setpoint(s) are NOT separately adjustable for each range.

It is available in multipliers of "10" only.

Example #1 - Conductivity/TDS: 758II-117-3R = 500 $\mu$ S (X1) w/ 5000 $\mu$ S (X10) & (X100) 50mS additional ranges.

Example #2 - Resistivity: 753II-11-3R = 20M $\Omega$  (X1) w/ 2M $\Omega$  (X.1) & 200K $\Omega$  (X.01) additional ranges.

As shipped from the factory, the number "1" Range position is the primary or the alarm/control position while the other positions are monitoring ONLY. In other words, while in the #2 (X.1) or #3 (X.01) position the alarm/controller is disabled. In the above example #2 the 20M $\Omega$  (X1) is the primary or alarm/control range.

### Specifications

NONE

### 2. INSTALLATION

Briefly -

The 3RO must be installed/mounted by user outside of the Monitor/controller housing by drilling a hole in user panel. For the 3RE, a cutout the size of the enclosure is required.

On a Conductivity Monitor/controller the Range Module is removed from Monitor/controller CB and re-installed on the 3R Switch Module. On a Resistivity Monitor/controller the Range Module is removed from Monitor/controller CB and a special 3 Range-Range Module is installed on the 3R Switch Module.

A cable harness from the 3R Module is connected to the main Monitor/controller circuit board in place of the Range Module. A separate small connector & harness is for the alarm/control disable or kill, and attaches to the small 2 pin male connector located to the left of the sensor input connectors on the main CB. **NOT INSTALLED ON MONITOR ONLY MODELS.**



### CAUTION - READ FOLLOWING CAREFULLY

**WARNING: BEFORE STARTING, IF MONITOR/CONTROLLER IS INSTALLED, ENSURE THE POWER IS OFF. FAILURE TO DO SO COULD CAUSE DAMAGE TO THE INSTRUMENT, AND COULD BE HARMFUL OR FATAL TO PERSONNEL. ONLY QUALIFIED PERSONNEL SHOULD INSTALL OR SERVICE**

## ELECTRICAL EQUIPMENT.

### Physical

3RO Module only - A suitable location must be found that is both convenient to the user and allow sufficient clearance for the 3 Range Switch Module to clear obstructions.

3RE - 3 Range Switch Module with enclosure, a cutout the size of the enclosure is required. Install enclosure per Operation Manual and skip to #4 below.

1. A 3/8" (9.5mm) hole must be drilled in the "user" panel. This hole must be situated in a location that allows the 3 Range Switch Module to be mounted.
2. Install label, aligning on the drilled hole.
3. Mount the 3 Range Switch Module to the panel with hardware supplied.
4. Remove the Range Module from the Main Monitor/controller CB.
5. For Conductivity models, re-install Range Module on to the 3 Range Switch Module in the LEFT location. For Resistivity models, install replacement SPECIAL 3 Range-Range Module, part number RM3R, on to the 3 Range Switch Module in the LEFT location. In both cases the arrow must be pointing toward the spot.
6. Attach cable harness from the 3 Range Switch Module to the main Monitor/controller CB in the place of the Range Module removed in step 4, as shown in figure III.G.1.
7. Attach the separate 2 wire cable harness from the 3 Range Switch Module to the 2 pin male connector S3 located to the left of the sensor input connectors on the main CB, as shown in figure III.G.1. **NOT INSTALLED ON MONITOR ONLY MODELS.**

### 3. ALARM/CONTROL CONFIGURATION

As shipped from the factory, the 3R Module is configured so that only the Primary or First switch position X1 is set to alarm/control, as shown in figure III.G.2. If your particular application requirements are different, the following will help you to reconfigure the alarm/control function to another range or add a controlling range. Pick the appropriate scenario below.

**NOTE: the setpoints will not change nor are they separately adjustable for each range.**

If adding an alarm/control range.

1. Locate the 8 position select switch on the 3SR Module.
2. Set appropriate select switch UP or ON, i.e. to add X100, set switch marked X100 UP or ON, see figure III.G.3.

If changing alarm/control from one range to another, i.e. X1 to X10 Range.

1. Locate the 8 position select switch on the 3SR Module.
2. Set the **X1** select switch in the DOWN or OFF position.
3. Set the **X10** select switch in the UP or ON position, see figure III.G.4.

To disable either COND/TDS or Resistivity alarm/control function completely.

1. Locate the 8 position select switch on the 3SR Module.
2. Set all **X** prefixed type select switches in the DOWN or OFF position, see figure III.G.5.

To reconfigure Conductivity to Resistivity or vice versa. If you have a Resistivity Monitor/controller and ordered a

3RO Module as an accessory you may need to reconfigure the select switch for it to Range properly.

1. Locate the 8 position select switch on the 3R Module.
2. Set the **COND** select switch in the DOWN or OFF position, see figure III.G.6.
3. Set the **RES** select switch in the UP or ON position, see figure III.G.6.

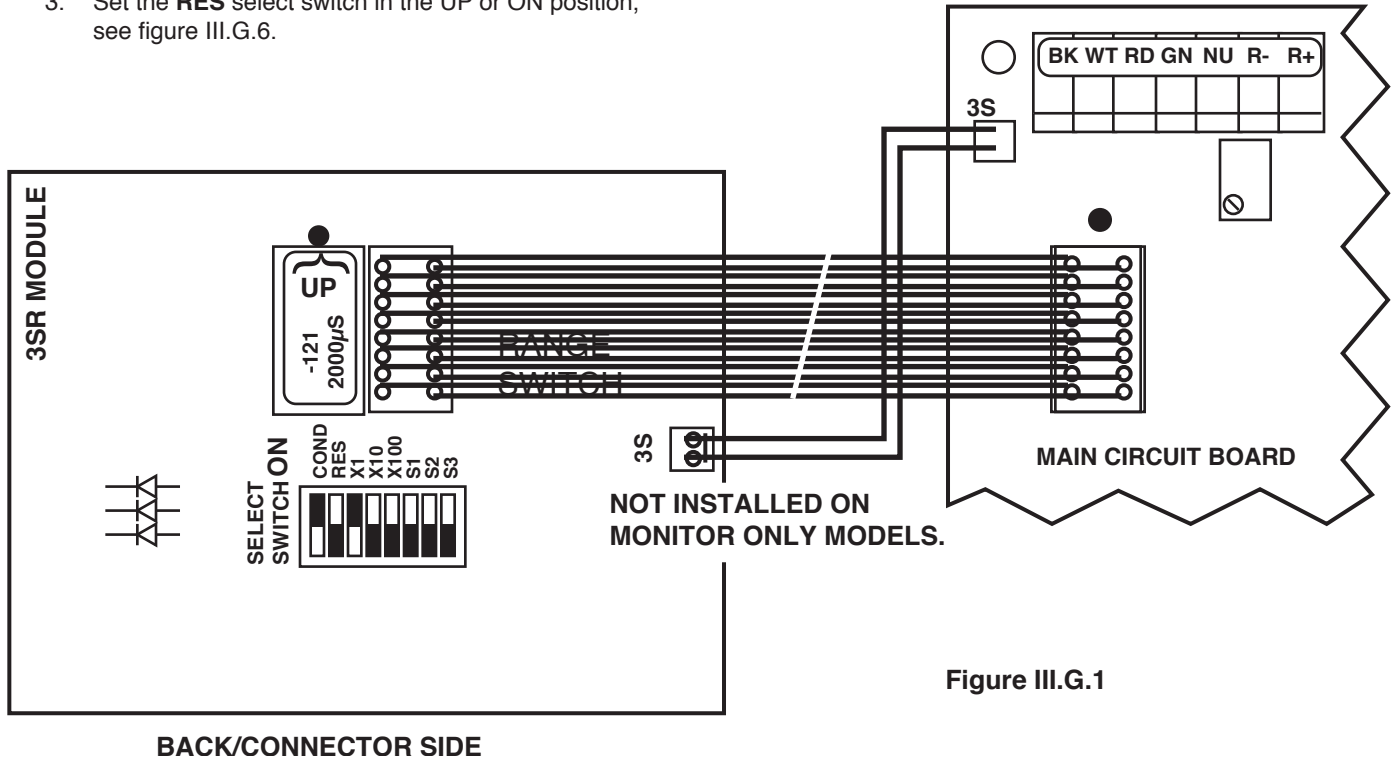


Figure III.G.1



Figure III.G.2  
Factory Default



Figure III.G.3

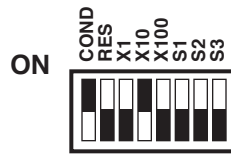


Figure III.G.4

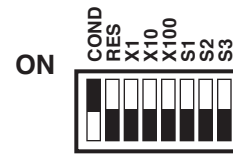


Figure III.G.5

Naturally, if you have a 3R Module configured for a Resistivity Monitor/controller and desire it to be for a Conductivity Monitor/controller reverse #2 & 3 above.

**REASSEMBLY**

1. Carefully reinstall the front panel, bottom first. Ensure no wires have been pinched between enclosure and front panel.
2. Reinstall the four (4) screws and tighten.
3. To operate, turn power **ON**.



Figure III.G.6



## H. 3 SENSOR / 3 RANGE MODULE

3SRO 3 Sensor / 3 Range Switch Module with 3 foot / 1 meter cable ordered separately (customer installed and mounted).

3SRE 3 Sensor / 3 Range Switch Module with 3 foot / 1 meter cable AND separate Enclosure (as an accessory). Enclosure is the same size as the Monitor/controller - 4.8"W x 6"H x 3.9"D.

### 1. DESCRIPTION

3 Sensor / 3 Range Switch Module is a circuit board (CB) with 2 rotary switches, and 3 groups of 5 sensor connectors where up to three sensors may be connected.

The 3SR will function with all Conductivity/TDS and Resistivity models, analog or digital. For ease of description, 3SR will be used throughout, and in the following description each switch function will be described separately.

The **3 Sensor Switch** allows the user to view 3 separate sensor locations and to set the alarm/control function using only one Monitor/controller.

As shipped from the factory, the number "1" **Sensor** position is set to be the primary or the controlling sensor while the other sensor positions are monitoring ONLY. This feature disables or stops the alarm/control function from operating when changing sensors. In other words, while in the #2 or #3 position the alarm/controller is disabled NO ALARM or CONTROL. However, any of the sensor positions may be selected to control by resetting the select switches as shown on the CB and described below.

The **3 Range Switch** allows the user to select which "range" (Cond/TDS = X1, X10 or X100 / RES X1, X.1 or X.01) to view, and to set for alarm/control function. The 3R may be configured - via select switches - to disable or stop the alarm/control function from operating when changing ranges.

It is available in multipliers of "10" only.

Example #1 - Conductivity/TDS: 758II-117-3R = 500 $\mu$ S (X1) w/ 5000 $\mu$ S (X10) & 50mS (X100) additional ranges.

Example #2 - Resistivity: 753II-11-3R = 20M $\Omega$  (X1) w/ 2M $\Omega$  (X10/X.1) & 200K $\Omega$  (X100/X.01) additional ranges.

As shipped from the factory, the number "1" **Range** position is the primary or the alarm/control position while the other positions are monitoring ONLY. In other words, while in the #2 (X.1) or #3 (X.01) position the alarm/controller is disabled. In the above example #2 the 20M $\Omega$  (X1) is the primary or alarm/control range.

NOTE: It is NOT possible to have different alarm/control settings for each sensor and range combination. The alarm/control function will always be the same as a percentage of full scale.

### Specifications

NONE

### 2. INSTALLATION

Briefly -

The 3SR & 3SRO must be installed/mounted by the user outside of the Monitor/controller enclosure by drilling two (2) holes in user panel. For the 3SRE, a cutout the size of the enclosure

is required.

A five conductor cable is connected to the 3SR Switch Module. This cable is connected to the main Monitor/controller circuit board (CB) at the sensor input connectors.

On a Conductivity Monitor/controller, the Range Module is removed from Monitor/controller CB and re-installed on the 3SR Switch Module as marked.

On a Resistivity Monitor/controller the Range Module is removed from Monitor/controller CB and a special 3 Range-Range Module is installed on the 3SR Switch Module as marked.

A cable harness from the 3SR Switch Module is connected to the main Monitor/controller circuit board in place of the Range Module.

A separate 2 wire connector & harness is for the alarm/control disable or kill, and attaches to the small 2 pin male connector S3 located to the left of the large input sensor connectors on the main control CB. **NOT INSTALLED ON MONITOR ONLY MODELS.**



### CAUTION - READ FOLLOWING CAREFULLY

**WARNING: BEFORE STARTING, IF MONITOR/CONTROLLER IS INSTALLED, ENSURE THE POWER IS OFF. FAILURE TO DO SO COULD CAUSE DAMAGE TO THE INSTRUMENT, AND COULD BE HARMFUL OR FATAL TO PERSONNEL. ONLY QUALIFIED PERSONNEL SHOULD INSTALL OR SERVICE ELECTRICAL EQUIPMENT.**

### Physical

3SRO Switch Module only - A suitable location must be found that is both convenient to the user plus allows sufficient clearance for both switches and the CB to clear any obstructions. 3SRE - 3 Sensor / 3 Range Module with enclosure, a cutout the size of the enclosure is required. Install enclosure per Operation Manual and skip to #4 below.

1. Two 3/8" (9.5mm) holes must be drilled on 2" (26mm) centers in the "user" panel. These holes must be situated in a location that allows the 3SR Switch Module to be mounted.
2. Install label, aligning on the drilled holes.
3. Mount the 3SR Switch Module to the panel with hardware supplied.
4. Attach 5 wire cable harness from the 3SR Switch Module to the main Monitor/controller CB at the sensor input location as shown on connector label.
5. Remove the Range Module from the Main Monitor/controller CB.
6. For Conductivity models, re-install Range Module onto the 3SR Switch Module in the LEFT location as marked.  
For Resistivity models install replacement SPECIAL 3 Range-Range Module, part number RM-18 onto the 3SR Switch Module in the LEFT location.
7. Attach cable harness from the 3SR Switch Module to the main Monitor/controller CB in the place of the removed Range Module, as shown in figure III.H.1.
8. Attach the separate small cable harness from the 3SR Switch Module to the small 2 pin male connector located to the left of the sensor input connectors on the main CB, as shown in figure III.H.1. **NOT INSTALLED ON MONITOR ONLY MODELS.**

### Sensor Connections

For convenience, it is recommended you connect the Primary or controlling sensor to SENSOR 1 position as shown in figure III.H.1.

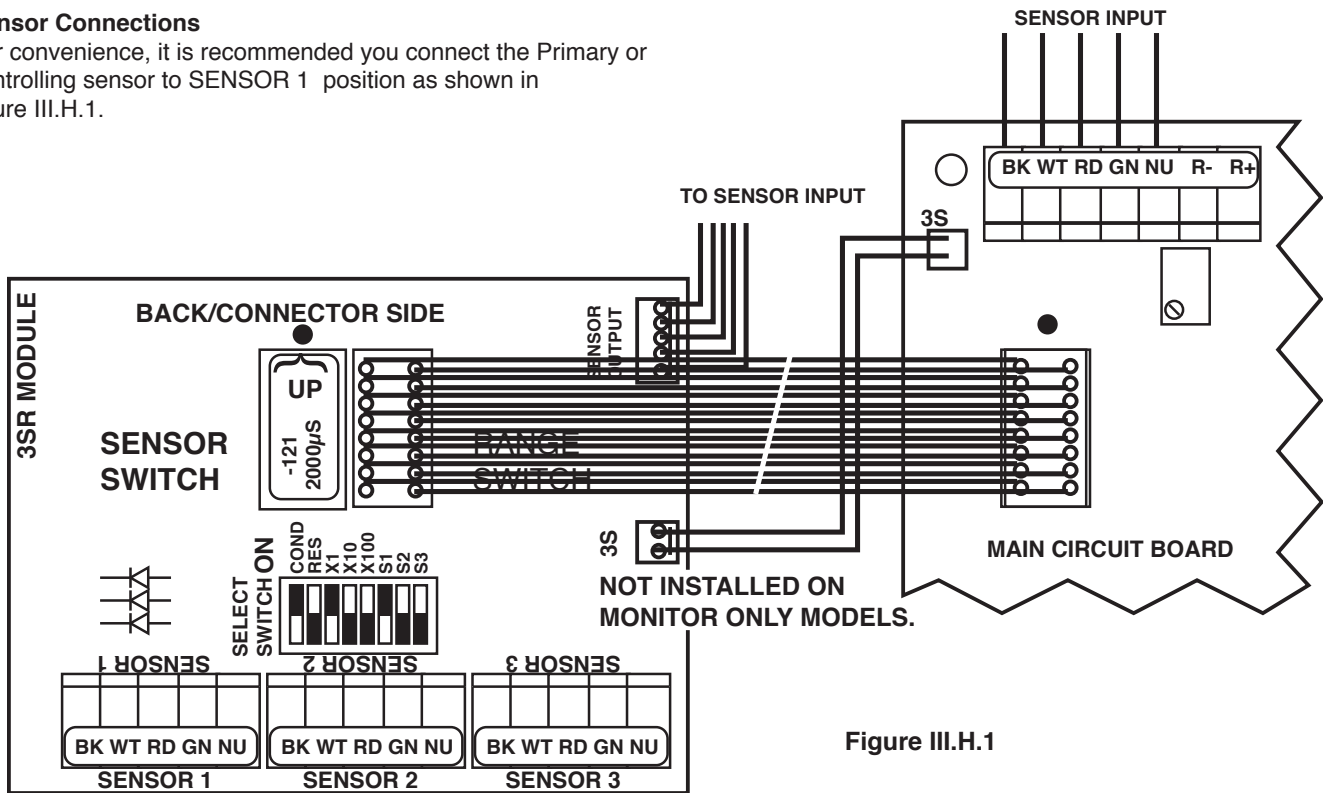


Figure III.H.1

### 3 SENSOR/3 RANGE INPUT MODULE 3SR



Figure III.H.2  
Factory Default



Figure III.H.3



Figure III.H.4



Figure III.H.5

**CAUTION:** The sensor connectors require only a small screwdriver or a pen to push on the release lever. Follow the color code as marked. The release levers may be broken or damaged if not pushed straight toward the CB. DO NOT push the release levers sideways.

### 3. ALARM/CONTROL CONFIGURATION

#### Sensor Switch

As shipped from the factory, the 3SR Module is configured so that only the Primary or First switch position “S1” is set to alarm/control, figure III.H.2. If your particular application requirements are different, the following will help you to reconfigure the alarm/control function to another sensor or add a controlling sensor. Pick the appropriate scenario below.

**NOTE:** the setpoints will not change nor are they separately adjustable for each sensor.

If adding an alarm/control sensor.

1. Locate the 8 position select switch on the 3SR Module.
2. Set appropriate select switch UP or ON, i.e. to add S3 sensor, set switch marked S3 UP or ON, see figure III.H.3.

If changing alarm/control from one sensor to another, i.e. S1 to S2 sensor.

1. Locate the 8 position select switch on the 3SR Module.
2. Set the S1 select switch in the DOWN or OFF position.
3. Set the S2 select switch in the UP or ON position, see figure III.H.4.

To disable the Sensor alarm/control function completely.

1. Locate the 8 position select switch on the 3SR Module.
2. Set all X prefixed and S prefixed select switches in the DOWN or OFF position, see figure III.H.5.

#### Range Switch

As shipped from the factory, the 3SR Module is configured so that only the Primary or First switch position X1 is set to alarm/control, figure III.H.6. If your particular application requirements are different, the following will help you to reconfigure the alarm/control function to another range or add a controlling range. Pick the appropriate scenario below. The setpoints will not change nor are they separately adjustable for each range.

**NOTE:** The Range Switch is labeled:

**For Conductivity/TDS - X1, X10 and X100.  
For Resistivity - X1, 0.1, and 0.01.**

If adding an alarm/control range.

1. Locate the 8 position select switch on the 3SR Module.
2. Set appropriate select switch UP or ON, i.e. to add X100, set switch marked X100 UP or ON, see figure III.H.7.



**Figure III.H.6**

**Factory Default**



**Figure III.H.7**



**Figure III.H.8**



**Figure III.H.9**

If changing alarm/control from one range to another, i.e. X1 to X10 Range.

1. Locate the 8 position select switch on the 3SR Module.
2. Set the **X1** select switch in the DOWN or OFF position.
3. Set the **X10** select switch in the UP or ON position, see figure III.H.8.

To disable either COND/TDS or Resistivity alarm/control function completely.

1. Locate the 8 position select switch on the 3SR Module.
2. Set all **X** prefixed and **S** prefixed select switches in the DOWN or OFF position, see figure III.H.9.

To reconfigure Conductivity to Resistivity or vice versa.

If you have a Resistivity Monitor/controller and ordered a 3SRO Module as an accessory you may need to reconfigure the select switch for it to Range properly.

1. Locate the 8 position select switch on the 3SR Module.
2. Set the **COND** select switch in the DOWN or OFF position, see figure III.H.10.
3. Set the **RES** select switch in the UP or ON position, see figure III.H.10.

Naturally, if you have a 3SR Module configured for a Resistivity Monitor/controller and desire it to be for a Conductivity Monitor/controller, reverse #2 & 3 above.



**Figure III.H.10**

**REASSEMBLY:**

1. Carefully reinstall the front panel, bottom first. Ensure no wires have been pinched between enclosure and front panel.
2. Reinstall the four (4) screws and tighten.
3. To operate, turn power **ON**.

## I. PIEZO ELECTRIC ALARM

- PA Piezo Electric Alarm ordered with Digital Monitor/controller.
- PAO Piezo Electric Alarm ordered separately for Digital or remotely mounted Analog Monitor/controller or OEM models.

### 1. DESCRIPTION

The PA/PAO is an electronic sound device capable of emitting a 80dB or more @ 30cm, high pitched squeal. See figure III.I.1.

### Specifications

- Oscillating Frequency — 3.0±0.5KHz
- Operating Voltage (750II) — 24VDC Nom. (1.5-30VDC Max.)
- Sound Pressure Level (Min) 30cm/12VDC — 80dB
- Current consumption (Max) @ 12VDC — 12mA
- Tone — Constant
- Operating Temperature — -20 - +60°C
- Size — 24 x 9.5 mm

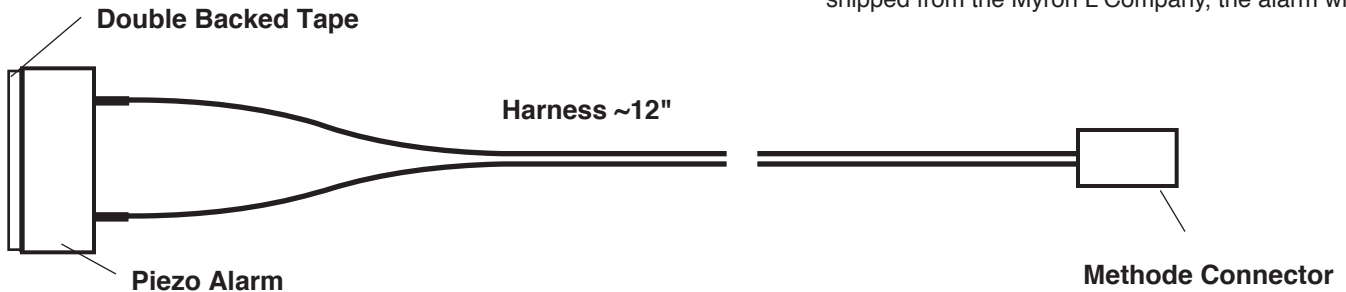


Figure III.I.1

### 2. INSTALLATION

Briefly -

The PA/PAO Piezo Alarm attaches to the front panel with the tape supplied, see figure III.I.3.

The wire harness plugs into a methode connector on the main CB\*, see figure III.I.4.

\* May also be connected to the SC Module as shown in figure III.I.5, if desired or so equipped.



### CAUTION - READ FOLLOWING CAREFULLY

**WARNING:** BEFORE STARTING, IF MONITOR/CONTROLLER IS INSTALLED, ENSURE THE POWER IS OFF. FAILURE TO DO SO COULD CAUSE DAMAGE TO THE INSTRUMENT, AND COULD BE HARMFUL OR FATAL TO PERSONNEL. ONLY QUALIFIED PERSONNEL SHOULD INSTALL OR SERVICE ELECTRICAL EQUIPMENT.

### Physical

**NOTE:** Remote mounting will require a .25" (6.35mm) hole, and extending the harness. Use #22 gauge speaker wire. Observe polarity.

If the front panel has all ready been removed from the enclosure skip to #4.

1. Using a standard slot screwdriver remove the four (4) screws on the front panel.

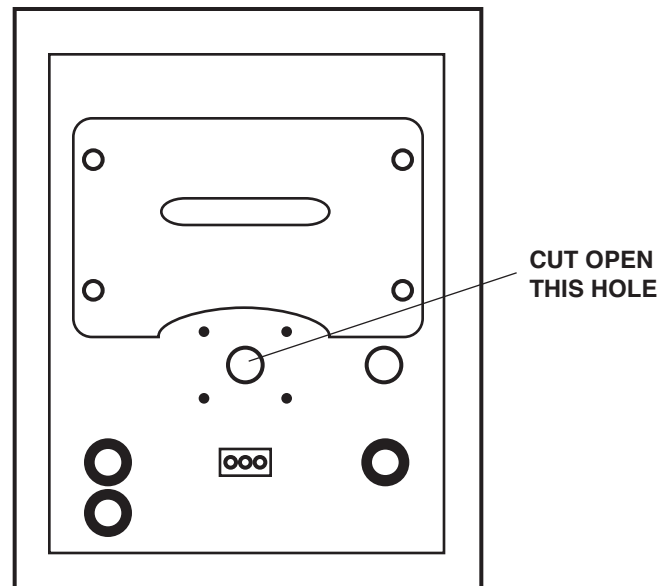
2. Carefully wiggle the front panel to loosen. Pull gently toward you. Do not pull more than about 8 inches/20CM or you could damage the wiring harness.
3. Turn the front panel around so that the back side is facing you.
4. Using a 1/4" drill or a sharp knife, carefully open the CENTER front hole in the front panel as shown in figure III.I.2.
5. Peel off tape backing from PA, and install between guides as shown in figure III.I.3.
6. Set front panel aside.
7. Connect wire harness to Main CB as shown in figure III.I.4, or to SC as shown in figure III.I.5.

### Test

1. Turn power **ON**. Depending on configuration, the Piezo will sound off when —.

**NOTE:** If the sensor is connected, the solution value, set point value and Set Point Conversion (SPC) jumpers may affect the test.

- a. For a Conductivity/TDS Monitor/controller, as shipped from the Myron L Company, the alarm will



FRONT PANEL  
Rear View

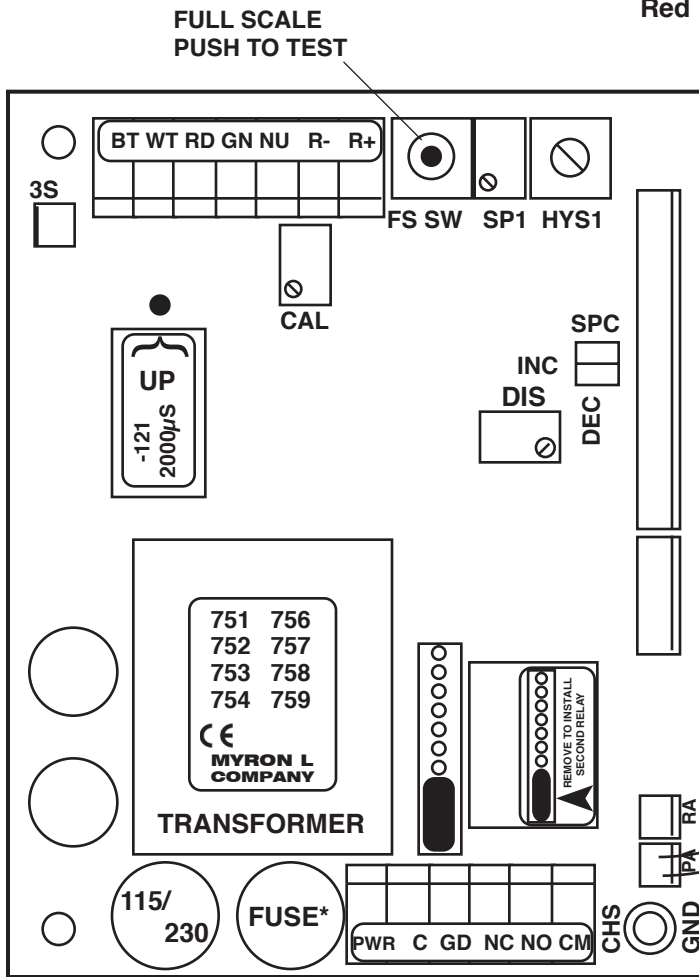
Figure III.I.2

- a. For a Conductivity/TDS Monitor/controller, as shipped from the Myron L Company, the alarm will sound off when the Full Scale Test Switch is pressed.
  - b. For a Resistivity Monitor/controller, as shipped from the Myron L Company, the alarm will sound off when the power is applied and stop when the Full Scale Test Switch is pressed.
  - c. If the Set Point Conversion (SPC) jumpers have been reversed, the opposite will be true in the above descriptions.
2. Turn power **OFF**.

**REASSEMBLY**

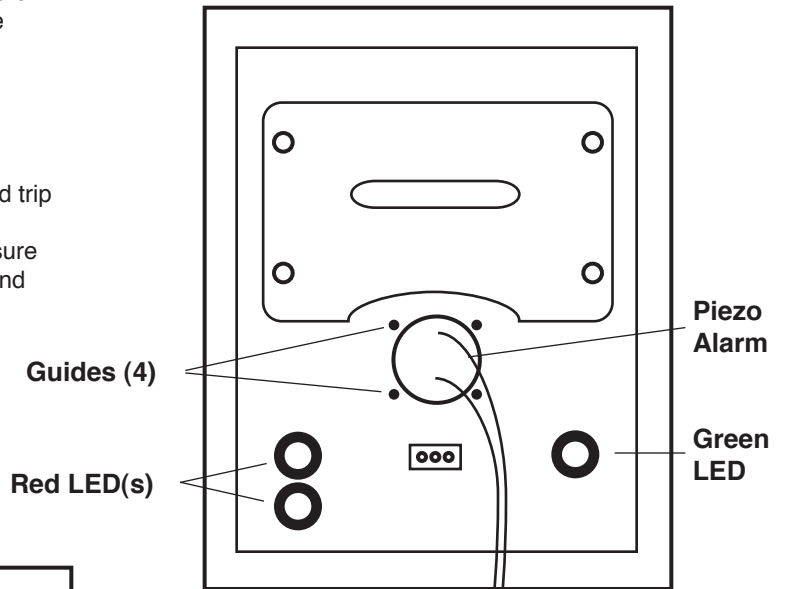
Before reassembly, ensure set point control is set to desired trip point.

1. Carefully reinstall the front panel, bottom first. Ensure no wires have been pinched between enclosure and front panel.
2. Reinstall the four (4) screws and tighten.
3. To operate, turn power **ON**.

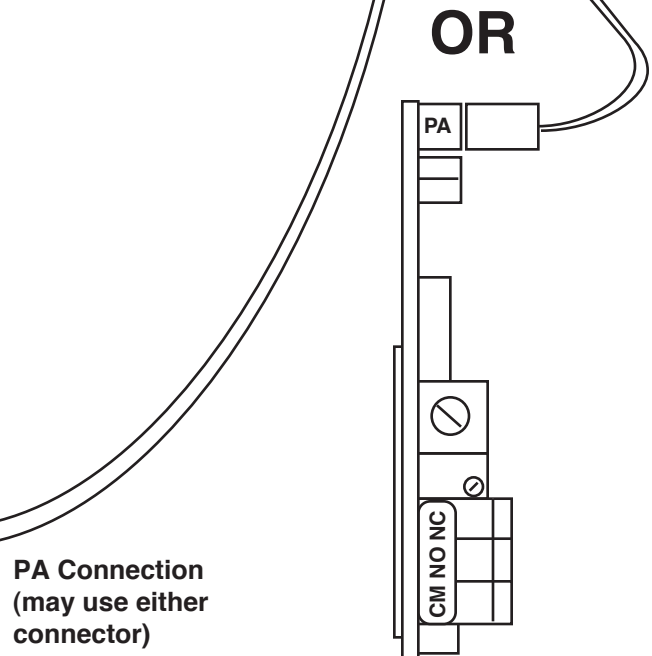


**MAIN CB ASSEMBLY**

Figure III.I.4



**FRONT PANEL  
Rear View  
Figure III.I.3**



**SC MODULE**

Main CB NOT shown for clarity

Figure III.I.5

## J. REMOTE ALARM - RA™

RA Ordered as an accessory, includes 8" harness with connector, and two (2) wire nuts.

### 1. DESCRIPTION

This remotely mounted AUDIBLE and VISUAL alarm connects to any Myron L Company Monitor/controller, or brand "X" controller with dry contacts. When activated by the controller the Remote Alarm will provide both an audible and a visual alert at a location other than at the controller.

A mute button will silence the piezo alarm for up to 10 minutes while the LED remains illuminated. After the preset time the piezo alarm will again sound, this will repeat until the water quality is corrected. Thus allowing servicing of the system under control, while still acting as a reminder if the problem has not been corrected.

The Remote Alarm - RA™ is an inexpensive way to alert personnel of a trouble situation. For example; the Monitor/controller may be located with an RO system while the service technicians are on another floor or even in another building - great for hospitals. The AUDIBLE alarm may be silenced, but stays in alarm (RED LED is still illuminated) until the trouble is corrected. The timer may be set from 15 seconds up to 10 minutes, thereby, giving personnel the time to correct the problem while not being able to ignore the trouble because of the reoccurring AUDIBLE and VISUAL alerts.

### Specifications

Audible Alert — Piezo Electric

Oscillating Frequency —  $3.0 \pm 0.5$  KHz

Operating Voltage (750II) — 24VDC Nom.  
(1.5-30VDC Max.)

Sound Pressure Level (Min) 30cm/12VDC — 80dB

Current consumption (Max) @ 12VDC — 12mA

Tone — Constant

Operating Temperature — -20 - +60°C

Size — 24 x 9.5 mm

Visual Alert — Bright RED LED

Time Delay — 15 seconds to 10 minutes (USER adjustable)

Power — 24VDC (supplied from Monitor/controller)

Case Material — ABS plastic

Dimensions — 4.75L x 2.56W x 1.56H (121L x 65W x 40H)

Mounting — Customer supplied screws

Operational Distance — Wire lengths of 500 feet (152 meters)  
have been tested with no adverse effects

Additional Wire available, order RAW-200. — 200 feet (61 meters)

### 2. INSTALLATION

Briefly —

Only 2 wires to connect from the controller to the RA.

Set the time.

Mount on the wall or on the bench.



### CAUTION - READ FOLLOWING CAREFULLY

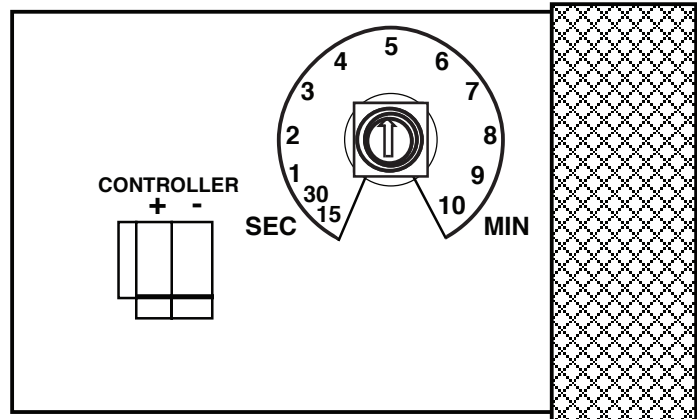
**WARNING: BEFORE STARTING, IF MONITOR/CONTROLLER IS INSTALLED, ENSURE THE POWER IS OFF. FAILURE TO DO SO COULD CAUSE DAMAGE TO THE INSTRUMENT, AND COULD BE HARMFUL OR FATAL TO PERSONNEL. ONLY QUALIFIED PERSONNEL SHOULD INSTALL ELECTRICAL EQUIPMENT.**

The Remote Alarm - RA connector is labeled **24VDC INPUT** and has a 8" 2 conductor wires attached — Black is Positive (+) and White is Negative (-).

When extending the wires you may use any two color wire you wish just remember the polarity — Black is Positive (+) and White is Negative (-). Wire lengths of 500 feet/152 meters have been tested and have no adverse effect on performance although a length of 500 feet/152 meters would be unusually long.

Ensure the unit is completely wired, tested and adjusted before installing RA to mounting surface.

For OEM models skip steps referencing enclosure or front panel.



RA CB ASSEMBLY

Figure III.J.1

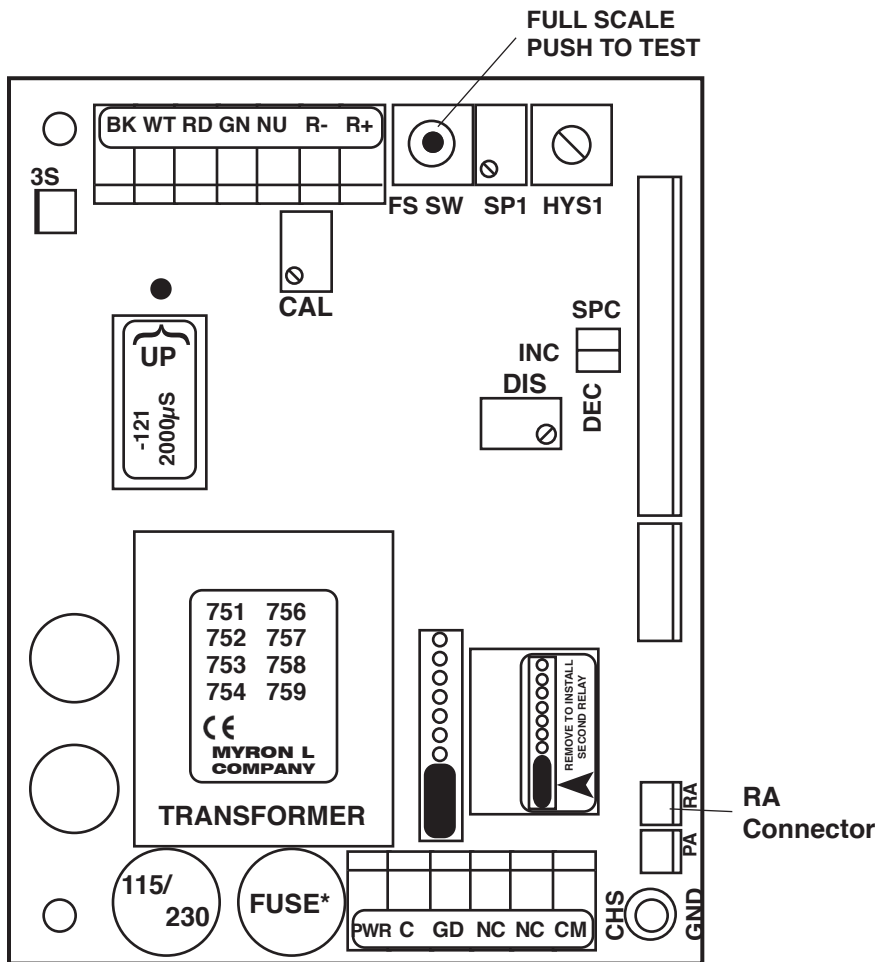
1. Run #22, 2 conductor speaker type wire, NOT supplied, from Monitor/controller to RA location as necessary. Wire may be ordered from the Myron L Company, part #RAW-200.
2. Open the RA by removing the four (4) screws.
3. Locate and remove the 8" 2 conductor wire with the reddish brown connector attached to the RA. See figure III.J.1.
4. At the RA, connect the extension wires to the connector on the RA circuit board — Black to Positive (+) and White to Negative (-) as shown in figure III.J.1.
5. Using a standard slot screwdriver remove the two (2) screws on the Myron L Monitor/controller front panel.
6. Carefully wiggle the front panel to loosen and pull gently toward you. Do not pull more than about 8 inches/20CM or you could damage the wiring harness.
7. Connect the extension wires to the 8" 2 conductor wire with the wire nuts provided — Black to Positive (+) and White to Negative (-). Be sure to first pass the wire through the user supplied waterproof strain relief in the enclosure.
8. Plug the reddish brown connector into the male connector on the controller circuit board marked RA (see inside case label or figure III.J.2 for location). It will only go on the connector one way.
9. To test, simply turn **ON** the controller and adjust controller set point until the alarm sounds off\*. If controller is not yet connected to water, on conductivity/TDS controllers it will be necessary to press and hold the Full Scale Test Switch. See figure III.J.2. The black button on the front of the RA will mute the piezo

alarm for approximately three minutes or until you improve the water quality (readjust controller set point). If three minutes muting is fine for your application, skip to #10.

10. If three minutes is too long or too short, adjust control inside RA until desired mute time is achieved (adjustable from approximately 15 seconds to 10 minutes). See figure III.J.1.
11. Replace the bottom of the RA, and secure to surface you have selected for its installation.
12. Carefully reinstall the controller front panel, bottom first. Ensure no wires have been pinched between enclosure and front panel.
13. Reinstall the four (4) screws and tighten.
14. To operate, turn power **ON**.

**\*NOTE:** If the RA does not sound off;

1. Check the polarity of the extension wire connections.
2. Be sure the controller is actually switching (relay will click).



**MAIN CB ASSEMBLY**

**Figure III.J.2**

# IV. OPERATING PROCEDURES

## A. FRONT PANEL INDICATORS & CONTROLS

The front panel illustrations to the right, switch and indicator operational descriptions have been provided to assist the user in identifying and operating the 750 Series II Monitor/controllers. For OEM models see Section B.

Refer to Section IV.C for Setup procedures and Section IV.D for Check-Out procedures.

### 1. RED "HIGH SET POINT" LED INDICATOR

The red LED indicator light is ON only when the water's conductivity/TDS reading is HIGH or ABOVE the set point adjustment (LOW or BELOW on Resistivity). May be reversed if desired.

### 2. GREEN "LOW SET POINT" LED INDICATOR

The green LED indicator light is ON only when the water's conductivity/TDS reading is LOW or BELOW the set point adjustment (HIGH or ABOVE on Resistivity). May be reversed if desired.

### 3. "SET POINT" SWITCH(ES)

When the "SET POINT" switch is depressed, the internal set point reading is immediately displayed on the front panel display. See figures IV.A.1 thru 4.

### 4. ANALOG METER OR DIGITAL LCD

Front panel analog meter or digital display provide a continuous readout of the water being monitored.

Conductivity/TDS Models 756II & 757II and Resistivity Models 751II & 752II are equipped with analog meter only. See figure IV.A.4.

Conductivity/TDS Models 758II & 759II and Resistivity Models 753II & 754II are equipped with a 3 1/2 digit, 1/2" Liquid Crystal Digital Display, as shown in figures IV.A.1 thru 3 & 5, with a 4 1/2 digit backlit LCD as an option.

### 5. OPTIONAL FRONT PANEL ITEMS

TP/TPO Module Switch

A digital Monitor controller with the optional TP/TPO Temperature Module, see picture at right, has an additional switch on the front panel. This push-button momentary switch when pushed gives the user a direct reading of the temperature of the solution from 0-200°C. Additional option TH/THO includes a control function capability. Mounts in the lower left corner of the upper panel, see figure IV.A.1.

Full Scale Test Switch (PTS/FST)

This optional feature allows the user to see the Full Scale TEST value without opening the enclosure to push the internal switch. Mounts in the lower left corner of the upper panel, see figure IV.A.3. unless ordered with TP Module than FST mounts in the lower center of the upper panel, see figure IV.A.1.

Piezo Alarm

Audible alarm sounds off automatically when the set point is reached. Figure IV.A.3. shows the location of this option.



Figure IV.A.1

Digital Conductivity Monitor/controller with optional Dual Alarm/controls, and Temperature with control function, and Front Panel Test Switch.

758II-121-SC-TP-THH-PTS

Digital Conductivity Monitor/controller with optional Dual Alarm/controls

758II-121-SC



Figure IV.A.2



Figure IV.A.3

Digital Conductivity Monitor/controller with optional Front Panel Test Switch, Single Alarm/control, and Piezo Alarm.

758II-121-PTS-PA

Analog Conductivity Monitor/controller (Single Alarm/control)

757II-112

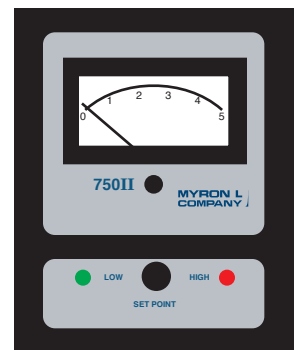


Figure IV.A.4



Figure IV.A.5

Digital Resistivity Monitor

754II-11



**B. OEM FRONT PANEL INDICATORS & CONTROLS**

The simulated OEM front panel illustrations to the right, and switch and indicator operational descriptions have been provided to assist the OEM user in identifying and operating the 750 Series II Monitor/controllers.

Refer to Section V.C. for Setup procedures, and Section V.D. for Check-Out procedures.

**1. RED “HIGH SET POINT” LED INDICATOR**

The red LED indicator light is ON only when the water’s conductivity/TDS reading is HIGH or ABOVE the set point adjustment (LOW or BELOW on Resistivity). May be reversed if desired.

**2. GREEN “LOW SET POINT” LED INDICATOR**

The green LED indicator light is ON only when the water’s conductivity/TDS reading is LOW or BELOW the set point adjustment (HIGH or ABOVE on Resistivity). May be reversed if desired.

**3. “SET POINT” SWITCH(ES)**

When the “SET POINT” switch is depressed, the internal set point reading is immediately displayed on the front panel display. See figures IV.B.1 thru 4.

**4. ANALOG METER OR DIGITAL DISPLAY**

Panel mounted analog meter or digital display provide a continuous readout of the water being monitored.

Conductivity/TDS Models 756II & 757II and Resistivity Models 751II & 752II are equipped with analog meter only as shown in figure IV.B.4.

Conductivity/TDS Models 758II & 759II and Resistivity Models 753II & 754II are equipped with a 3 1/2 digit, 1/2” Liquid Crystal Digital Display, as shown in figures IV.B.1 thru 3 & 5., with a 4 1/2 digit backlit LCD as an option.

**5. OPTIONAL PANEL MOUNTED ITEMS**

**TP/TPO Module Switch**

A digital Monitor/controller with the optional TP/TPO Temperature Module has an additional switch on the front panel as shown in figure IV.B.1. This push-button momentary switch when pushed gives the user a direct reading of the temperature of the solution from 0-200°C. Additional option TH/THO includes a control function capability. See figure IV.B.1.

**Full Scale Test Switch (PTS/FST)**

This optional feature allows the user to see the Full Scale TEST value without opening the panel to push the internal switch. See figures IV.B.1 and IV.B.3 for typical examples.

**Piezo Alarm**

Audible alarm sounds off automatically when the set point is reached. Mounted by OEM in any convenient location as shown in figure IV.B.3.

**WARNING: THE DISPLAY WILL BE IRREPARABLY DAMAGED IF THE HARNESS IS INSTALLED UPSIDE-DOWN. THE HARNESS MUST BE INSTALLED AS SHOWN IN FIGURE II.E.6.**

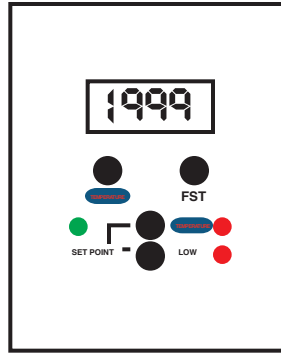


Figure IV.B.1

**Digital Conductivity Monitor/controller with optional Dual Alarm/controls**

758II-121-SC

**Digital Conductivity Monitor/controller with optional Dual Alarm/controls, and Temperature with control function, and Front Panel Test Switch.**

758II-121-SC-TP-THH-PTS

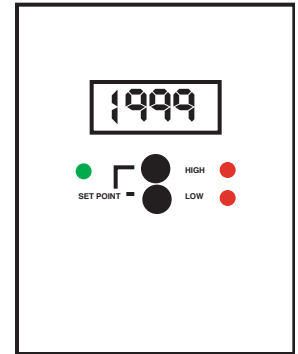


Figure IV.B.2

**Digital Conductivity Monitor/controller with optional Front Panel Test Switch, Single Alarm/control, and Piezo Alarm.**

758II-121-PTS-PA

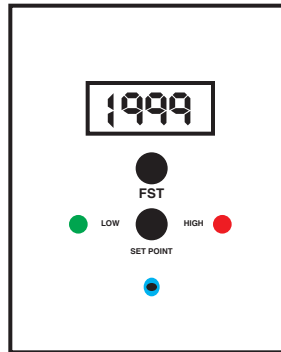


Figure IV.B.3

**Analog Conductivity Monitor/controller (Single Alarm/control)**

757II-112

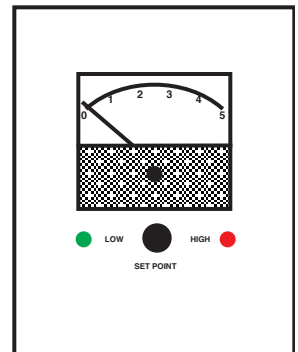


Figure IV.B.4

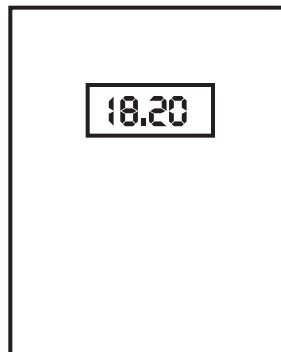


Figure IV.B.5

**Digital Resistivity Monitor**

754II-11

**NOTE: Boxes around displays to simulate OEM panels.**



## CAUTION - READ FOLLOWING CAREFULLY

### C. SETUP PROCEDURES

These Setup procedures cover (1) converting the alarm circuit to trigger on a decreasing (conductivity) or increasing (Resistivity) reading, (2) checking out your new Monitor/controller, (3) setting the alarm circuit setpoint(s), and (4) adjusting the hysteresis.

The following require that the front panel be removed. While doing so be careful not to strain the cable(s).

**NOTE:** A small screwdriver or tweaker will be required for several of the following operations.

#### 1. SET POINT CONVERSION (SPC) / REVERSING SET POINT

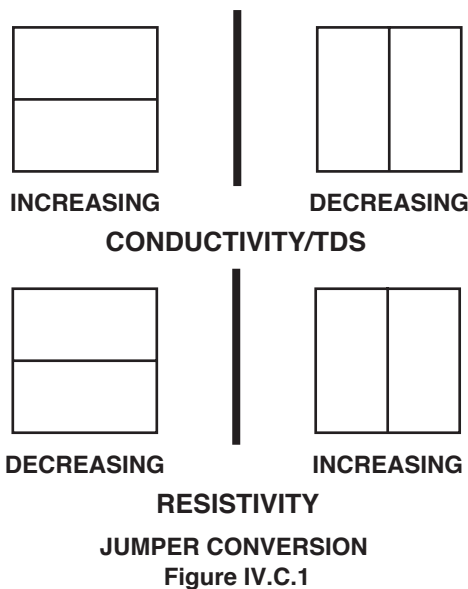
The alarm/control circuit(s) on all 750 Series II Conductivity/TDS Monitor/controllers are configured to trigger the alarm relay as the conductivity/TDS reading increases.

**NOTE:** The reverse is true for Resistivity Monitor/controllers which are configured to trigger on decreasing.

If the user's application requires it, the alarm circuit may be easily reconfigured to trigger the alarm relay as the conductivity (or ppm) reading decreases or increases for Resistivity. Refer to figure V.A.1. for the locations of the jumpers referred to in this section.

**NOTE:** These instructions describe the general procedures for converting the Monitor/controller without reference to jumper numbers or orientation.

1. Ensure power is **OFF**.
2. Locate the jumper block for the alarm to be configured.
3. Make a note of the current orientation of the jumpers.
4. Remove both jumpers. This is easily done by hand. Take care not to crush the jumpers if using pliers.
5. Rotate the jumpers 1/4 turn and reinstall them on their posts as shown in figure IV.C.1.



### 2. CHECK-OUT PROCEDURES

The following check-out procedures are used to verify that the 750 Series II Monitor/controller is operating properly. It is assumed that the Monitor/controller power is ON, that it is connected to a CS51 or appropriate Sensor, and that the Sensor is immersed in water within the range that the Monitor/controller will be required to read. Refer to figure V.A.1. for the locations of the components referred to in this section.

1. Make a note of the reading on the display.
2. Being careful not to strain the connecting cable(s), unfasten and remove the front panel.
3. While pressing the Calibration/Full Scale Test Switch (FS SW), verify that the front panel display is indicating a full scale reading. If not, see Calibration, section V.C.
4. Press and hold the "SET POINT" switch on the front panel. Using a tweaker or a small screwdriver, adjust the Set Point trimmer adjustment screw on the circuit board to sweep the display from zero to full scale. (A digital display may be blank at the full scale end. This is normal.) Listen for the alarm relay to click 'ON and OFF' as the alarm set point moves past the water reading.
5. Adjust the alarm to the desired set point value. Release the "SET POINT" switch.

**NOTE:** For Models with SC/SCO module, repeat STEPS 4 & 5 to check out Set Point #2.

### 3. SET POINT ADJUSTMENT

The set point setting is based upon the user's particular water purity specifications or requirements.

**NOTE:** The optional **second** relay/alarm is "stacked" on the first relay/alarm, therefore, when setting the optional **second** relay/alarm Set Point, the #1 Set Point must be 'set' first.

1. Being careful not to strain the cable, unfasten and remove the Monitor's front panel.
2. While depressing the "SET POINT" switch, turn the Set Point #1 adjustment screw (See figure V.A.1) until the desired set point value is indicated on the display.
3. If Hysteresis adjustment is required see below. If not, reinstall the front panel and tightly secure both retaining screws.

### 4. HYSTERESIS (DEAD BAND) ADJUSTMENT

The hysteresis or dead band is approximately  $\pm 3\%$  of the set point at full scale as it leaves the factory. Under normal (most) conditions it will not be necessary to adjust.

However, if you desire to make an adjustment please keep the following in mind.

The adjustment is very simple and is based on set point location. If the set point\* is in the upper 75-100% of the scale, the hysteresis control pot should be turned fully to the right.

If the set point is in the lower portion of the scale, i.e. 5-25% of scale, the control pot may be turned fully to the left.

If you are operating in the center, 25-75% of scale, the control pot may be adjusted in the center.

Or the hysteresis or dead band may be adjusted to tighten the control of a particular process.

**CAUTION:** adjusting the hysteresis too tight may cause the alarm to fluctuate (on-off) due to flow, chemical mixing or bubbles causing the relay to chatter. This condition is to be avoided, it could damage your valves, pumps, etc. and will eventually damage the relay.

\* Applies to both set points if so installed.

The following is assuming the front panel is already removed and the set points have been set, if not see above,

1. Locate the hysteresis control adjustment located next to the Set Point #1 (SP1) adjustment - it is a single turn pot. See figure V.A.1.
2. Adjust as described above or as desired.

#### **REASSEMBLY**

1. Carefully reinstall the front panel, bottom first. Ensure no wires have been pinched between enclosure and front panel.
2. Reinstall the four (4) screws and tighten.
3. To operate, turn power **ON**.

# V. COMPONENT IDENTIFICATION, CALIBRATION AND PREVENTIVE CARE

## A. PRIMARY COMPONENT IDENTIFICATION

As identified in Section III, the Monitors/controllers switch(es) and indicator components are mounted directly to the front panel.

The Monitor/controllers main circuit board is contained within and mounted to the back of the enclosure. Some models with options have an additional circuit board mounted behind the front panel, i.e. Model 758II-4A (4-20 Module).

Review figure V.A.1 below to familiarize yourself with the Main circuit board assembly. The following diagram has the second alarm/control module option installed.

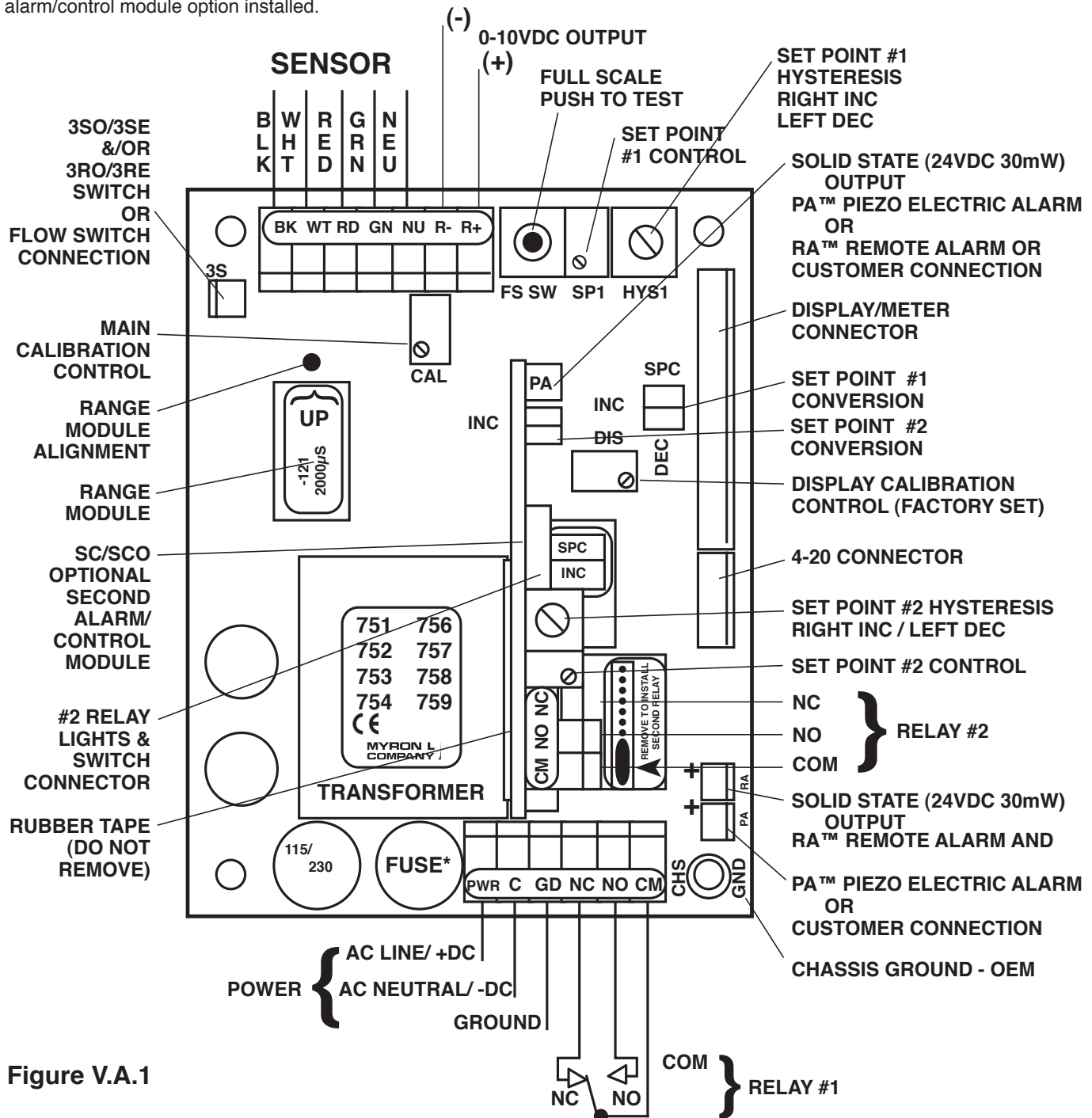


Figure V.A.1



## CAUTION - READ FOLLOWING CAREFULLY

### B. METER MECHANICAL ZERO PROCEDURES

#### ANALOG METERS ONLY

1. Ensure power is **OFF**.
2. Note the position of the meter needle. If it has come to rest pointing at the zero mark on the scale, turn the Monitor back ON and continue on to Section V.C.
3. Locate the small (approx. 1/4"), black plastic button directly below the center of the meter. Use a small screwdriver or a fingernail to gently pry it loose and remove it from the access hole. See figure II.G.9.
4. Insert a small standard screwdriver into the access hole and carefully locate the slot in the mechanical adjustment plug.
5. Turn the adjustment plug slightly until the needle rests on zero.
6. Insert the small plastic button into the access hole.
7. Turn power **ON**.

### C. CALIBRATION PROCEDURES

All Myron L Monitor/controllers are factory calibrated prior to shipping and are ready to install without further calibration. Calibration should be checked occasionally with the internal Calibration/Full Scale Test switch (FS SW) to ensure continued accuracy. The following procedures are provided in the event that recalibration becomes necessary. The only equipment required are a tweaker or small screwdriver, and standard solution. Refer to Figure V.A.1. to locate the components described in this section.

**NOTE:** When opening instrument, remove front cover with care; a ribbon cable connects the front panel and main board.

**When performing calibration procedures, the technician must take extreme care to avoid contacting the circuitry other than the CALibration control. Failure to do so could result in damage to the equipment, property and/or personal injury.**

#### 1. ELECTRONIC CALIBRATION (CIRCUIT ONLY)

This method is faster than the following method using standard solution, but it does not include the sensor. Therefore, it should be used only in applications where the chance of sensor contamination or damage are slight.

**NOTE:** The DISplay calibration control has been **set** and **sealed** prior to leaving the factory, and under normal conditions will not require readjustment. This allows the customer to use the panel meter/display to easily set the electronic Full Scale value. If the DISplay calibration control has been adjusted it will be necessary to, first, verify or adjust the Full Scale using a DVM as described in "Full Scale Calibration" below, followed by adjusting the DISplay calibration control to Full Scale on panel meter/display.

##### a. Full Scale Calibration

1. Ensure power is **OFF**.
2. Using a standard slot screwdriver remove the four (4) screws on the front panel.
3. Carefully wiggle the front panel to loosen and pull gently toward you. Do not pull more than about

8 inches/20CM or you could damage the wiring harness.

4. Turn the front panel around so that the back side is facing you and set aside.
5. Turn power **ON**.
6. Press and hold the Full Scale Test switch. The display should indicate Full Scale for the particular range selected, i.e. 0-500 ppm should indicate 500. If not, set to Full Scale with the CALibration control.

**NOTE:** When setting digital models with a full scale of 2000 (1999), it is advisable to adjust Full Scale to 1990, otherwise an overrange condition may occur.

7. Turn power **OFF**.
8. Re-install front panel as described below in "REASSEMBLY" or continue.
9. To operate, turn power **ON**.

##### b. 0-10VDC Recorder Output Calibration

For output voltages other than 10VDC, substitute as required, i.e. 5.00VDC or 2.00VDC per Section II.F.2.

Requires a DVM set to DC Volts.

1. Ensure power is **OFF**.
2. Attach DVM to RECORDER output connection.
3. Turn power **ON**.
4. Press and hold the Full Scale Test switch (FS SW).
5. The DVM should indicate 10.00VDC.
6. If not, adjust CALibration control until DVM indicates 10.00VDC.
7. Verify the panel meter/display, it should indicate Full Scale reading as shown on Range Module.
8. If not, adjust DISplay control until a full scale reading is displayed. When setting digital models with a full scale of 2000 (1999), it is advisable to adjust Full Scale to 1990, otherwise an overrange condition may occur.
9. Turn power **OFF**.
10. Re-install front panel as described below in "REASSEMBLY" or continue.
11. To operate, turn power **ON**.

#### 2. CALIBRATION USING STANDARD SOLUTION

The best method of recalibrating your conductivity/TDS Monitor/controller is with NIST traceable Standard Solution (available from the Myron L Company). Because it includes the sensor, the entire system is recalibrated.

**NOTE:** Since standard solution calibrations are NOT practicable with resistivity models, another means of verification or calibration of resistivity models is to use the transfer standard method, using a hand-held or portable instrument capable of resistivity measurements, i.e. the Myron L Ultrameter II™. See section V.C.4 description.

The following procedure describes the easiest method for standard solution calibration of your Conductivity/TDS Monitor/controller.

1. Using a standard solution which is 60-90% of full scale of the instrument, i.e. for 0-2000  $\mu$ S range use KCl-1800, rinse thoroughly and fill a clean glass beaker with the standard solution.
2. Place sensor in the beaker of standard solution. The level of standard solution must be high enough to cover at least 1/2" above cross hole.

3. Slowly shake the sensor to remove air bubbles from inside the sensor bore hole.
4. Allow 5-10 minutes for temperature to equilibrate. For the quickest and the best results, both the sensor and solution should be at the same temperature.
5. Turn power **ON**.
6. Read the display of the instrument. The display should match the value and units of measure located on the bottle of standard solution. If the reading is different, adjust **CAL**ibration control on the main circuit board until the reading matches the solution value. This will require removal of the front panel. For removal, see section V.C.1.a. 1-4.
7. After adjustment, turn power **OFF**.
8. Re-install front panel as described below in "REASSEMBLY".
9. To operate, turn power **ON**.

### 3. SENSOR SUBSTITUTE CALIBRATION

NIST traceable Sensor Substitutes are commonly use to verify and calibrate Resistivity Monitor/controllers. Normally they are not needed due to the "built-in " electronic calibration or "Full Scale Test". However, your requirements may be such that a crosscheck or verification is required. Sensor Substitutes are available from the Myron L Company, see accompanying chart, figure V.C.1, for part number.

If the proper Resistivity Sensor Substitute is not readily available and you can not wait for one to be delivered, one may be constructed using the equivalent resister values listed on the accompanying chart, figure V.C.1 and schematic, figure V.C.2.

RESISTIVITY MONITOR/CONTROLLER		
RANGE	PART NUMBER	RESISTER VALUE - X*
0-20 MΩ	CS-11	1 MΩ
0-10 MΩ	CS-12	500 KΩ
0-5 MΩ	CS-13	249 KΩ
0-2 MΩ	CS-14	100 KΩ
0-1 MΩ	CS-15	50 KΩ
0-500 KΩ	CS-16	24.9 KΩ
0-200 KΩ	CS-17	10 KΩ

Figure V.C.1

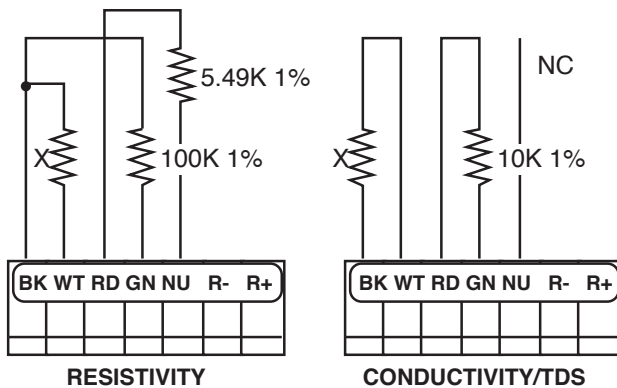
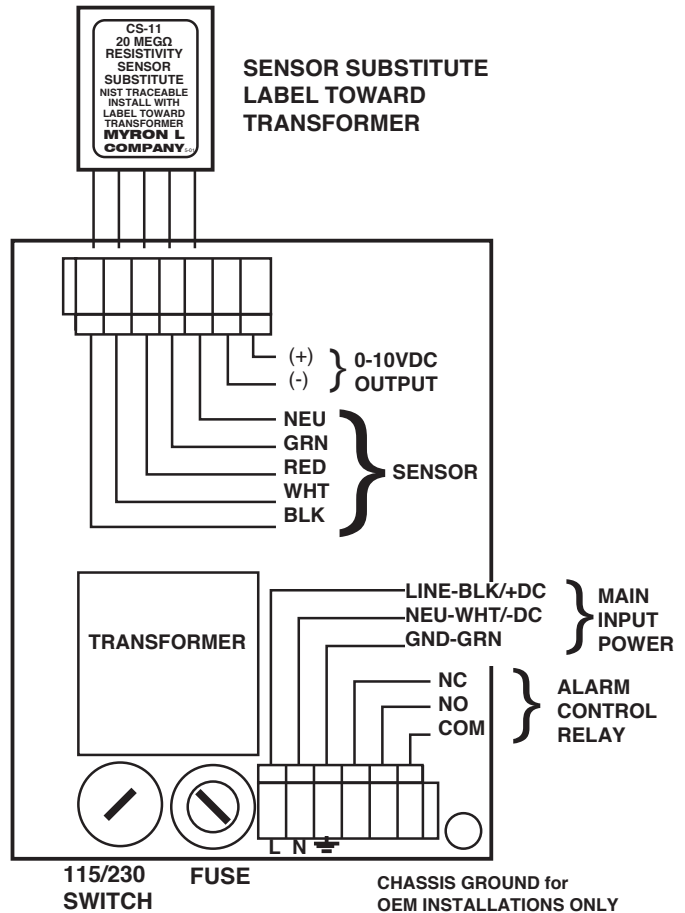


Figure V.C.2

**NOTE:** If you have previously performed a system calibration with either a NIST Standard Solution, or using the transfer standard method, using this procedure will make that calibra-

tion invalid. You must decide which is more important, a system calibration, or an electronic calibration.

1. Ensure power is **OFF**.
2. Using a standard slot screwdriver remove the four (4) screws on the front panel.
3. Carefully wiggle the front panel to loosen and pull gently toward you. Do not pull more than about 8 inches/ 20CM or you could damage the wiring harness.
4. Turn the front panel around so that the back side is facing you and set aside.
5. Locate and remove the sensor leads from the sensor connector as shown in figure V.C.3.
6. Install Sensor Substitute with label toward transformer as shown in figure V.C.3.
7. Turn power **ON**.
8. Display reading should be full scale of range. If not, adjust **CAL**ibration control to read full scale, i.e. 0-500 KΩ range should indicate 500, 0-10.00 MΩ = 10.00, and 0-20.00 MΩ = 20.00 at full scale. When setting digital models with a full scale of 2000 (1999), it is advisable to adjust Full Scale to 1990, otherwise an overrange condition may occur.
9. After adjustment, turn power **OFF**.
10. Re-install front panel as described below in "REASSEMBLY".
11. To operate, turn power **ON**.



ELECTRICAL CONNECT DIAGRAM

Figure V.C.3

#### 4. TRANSFER STANDARD METHOD

For maximum accuracy of any Monitor/controller, the transfer standard method should be utilized. Instead of removing the entire Monitor/controller and sensor, and either returning it to the manufacture or sending it to a third party laboratory for recertification, the transfer standard allows quick recertification and return to service — less down time. While being the most accurate method it is also very easy to perform, and may be used to calibrate ANY manufacture Monitor/controller — resistivity or conductivity/TDS. This method still has the benefit of third party verification, if so desired.

1. A high quality hand-held instrument, one capable of accurate conductivity/TDS and/or “resistivity” readings such as the Myron L Ultrameter II™, is calibrated using a standard solution, or if so desired, sent to a third party laboratory for calibration & certification. Preferably the standard solution should be as close as practicable to the area of the Monitor/controller operation, i.e. for a conductivity Monitor/controller that is operating between 1500 and 2000 $\mu$ S, the recommended Myron L standard solution is KCI-1800.

**NOTE:** For resistivity values, the Myron L Company can supply NaCl standards as low as ~25 $\mu$ S on special order. Extremely low values are available from other sources. Calibrated at 25 $\mu$ S the Ultrameter II is capable of very accurate resistivity measurements.

2. Once the Ultrameter II is calibrated, the process water is measured. (For resistivity measurements, follow the recommended procedure described in the Ultrameter II Operation Manual, section IV.B, Measuring Resistivity.)
3. Finally, the Monitor/controller is calibrated/adjusted to match the value measured by the Ultrameter II by adjusting the Main **CAL**ibration control shown in figure V.A.1.
4. Turn power **OFF**.
5. Re-install front panel as described below in “REASSEMBLY”.

#### REASSEMBLY

1. Carefully reinstall the front panel, bottom first. Ensure no wires have been pinched between enclosure and front panel.
2. Reinstall the four (4) screws and tighten.
3. To operate, turn power **ON**.

#### D. PREVENTIVE CARE

The Myron L Company recommends that the following Preventive Care procedures be observed.

1. Try to prevent exposure to excessive heat and moisture.
2. The Monitor’s main AC power source should be protected against excessive voltage “spikes.”
3. Take care not to damage the Monitor during handling.

**NOTE:** Daily, weekly or monthly maintenance schedules are based upon the frequency of use and the severity of the Monitor’s environment and operating conditions.

4. Repeat the Monitor’s Check-Out procedures to verify satisfactory operation and/or isolate possible troubleshooting symptoms.
5. Check all cable connections to ensure that they are

free of moisture and contamination.

6. Inspect and replace damaged component boards and cable assemblies.
7. Periodically remove, clean and inspect the Sensor.

CLEANING - clean front panel with soap and water, and soft non-abrasive cloth.

## VI. OPTIONS & ACCESSORIES

### A. OPTIONS ORDERED WITH MONITOR/CONTROLLER

<u>PART #</u>	<u>DESCRIPTION</u>
-SC	Second Alarm/control Module (Monitor/controllers only)
-4A	4-20mA Self-Powered Isolated Output Module (digital models only)
-PA	70 db Piezo Electric Alarm (mounted on front panel) (digital Monitor/controller models only)
-PAT	Piezo Alarm and Timer Module (digital Monitor/controller models only)
-35BL	3 1/2 Digit Backlit Liquid Crystal Display (LCD)
-45BL	4 1/2 Digit Backlit Liquid Crystal Display (LCD)
-TP	Temperature Module 0-200°C, Requires -TP Sensor (digital Monitor/controllers only)
-TH	TP/TPO Alarm/control Harness (requires SC & TP above) (digital models only)
-PC	Power cord <b>115VAC</b> (8 ft./2,44 meters with USA plug and strain relief)

### SPECIAL ORDER OPTIONS

-24VA	24 VAC Isolated Power Supply
-24VD	24 VDC Isolated Power Supply
-PTS	Panel mounted full scale test switch
-SFP	Panel mounted set point adjustment (digital Monitor/controllers only)
-TPA	Temperature Module 0-200°C, above -TP with adjustable hysteresis, (digital models only)
-HT	High Temperature modification for -HT sensors, range limited (contact Myron L technical sales)

### B. OPTIONS & ACCESSORIES ORDERED SEPARATELY

<u>PART #</u>	<u>DESCRIPTION</u>
ASI	AQUASWITCH I™, fully automatic RO/DI switching system (requires Monitor/controller)
SCO	Second Alarm/control Module only (Monitor/controllers only)
4AO	4-20mA Self-Powered Isolated Output Module (digital models only)
3SE	3 Sensor Input Module with Enclosure
3SO	3 Sensor Input Module with 1 meter/3 ft. Cable*
3RE	3 Range Switch with Enclosure (Add C=Cond or R=Res)
3RO	3 Range Switch with 1 meter/3 ft. cable (Add C=Cond or R=Res)*
3SRE	Above 3SO and 3RO combined with Enclosure (Add C=Cond or R=Res)
3SRO	Above 3SO and 3RO combined (Add C=Cond or R=Res)*
PAO	Piezo Electric Alarm only (digital Monitor/controllers only)
PATO	Piezo Alarm and Timer Module (digital Monitor/controllers only)
35BLO	3 1/2 Digit Backlit Liquid Crystal Display (LCD)
45BLO	4 1/2 Digit Backlit Liquid Crystal Display (LCD)
TPO	Temperature Module 0-200°C, Requires -TP Sensor (digital models only)
THO	TP/TPO Alarm/control Harness only (requires SCO and TPO above)
TPC	Calibration Module (temperature module)
PCO	Power Cord 115VAC (8 ft./2,44 meters with plug and strain relief) - NOT for 230VAC use
SMP50	Surface Mounting Plate
RA	Remote Alarm™ (Monitor/controllers only)
VR	Power Supply, 115 VAC to 24 VAC, 20VA. (indoor use only)
024-1	1in. NPT 24 VAC Solenoid Valve
CS-11	20 Megohms Resistivity Calibration Module (sensor substitute) NIST Traceable
CS-14	2 Megohms Resistivity Calibration Module (sensor substitute) NIST Traceable
CS-17	200 Kilohms Resistivity Calibration Module (sensor substitute) NIST Traceable
CC or RC	NIST Certificate without sensor (C = Cond or R = Res)
CCATF or RCATF	NIST Certificate without sensor, ordered after instrument has shipped (C=Cond or R=Res)
CCS	NIST Certificate with sensor, using standard solution (Conductivity/TDS only)

\* Does not fit into enclosure, must be mounted separately (Customer Installed).



## C. STANDARD SOLUTIONS & BUFFERS

### 1. CONDUCTIVITY/TDS STANDARD SOLUTIONS

Your Conductivity/TDS Monitor/controller has been factory certified to meet certain specifications based on the appropriate Myron L Company NIST traceable standard solutions. These same solutions are available to you.

#### DESCRIPTION

The Myron L Company manufactures three basic types of conductivity/TDS standard solutions — KCl, NaCl and 442™. See below.

Most Myron L standard solution bottles show three values referenced at 25°C:

Conductivity in microsiemens/micromhos, while the ppm/TDS equivalents are based on our 442 Natural Water™, and NaCl standards. All standards are within ±1.0% of reference solutions.

These same buffers may be used for calibration and recertification of your Myron L or other handheld instrument.

#### a. Potassium Chloride (KCl)

The concentrations of these reference solutions are calculated from data in the International Critical Tables, Vol. 6.

#### b. 442 Natural Water™

442 Natural Water Standard Solutions are based on the following salt proportions: 40% sodium sulfate, 40% sodium bicarbonate, and 20% sodium chloride which represent the three predominant components “anions” in freshwater. This salt ratio has conductivity characteristics approximating fresh natural waters and was developed by the Myron L Company over three decades ago. It is used around the world for measuring both conductivity and TDS in drinking water, ground water, lakes, streams, etc.

#### c. Sodium Chloride (NaCl)

This is especially useful in sea water mix applications, as sodium chloride is its major salt component. Most Myron L standard solution labels show the ppm NaCl equivalent to the conductivity and to ppm 442 values.

### 2. pH and ORP BUFFER SOLUTIONS

For your pH and/or ORP Monitor/controller. Your pH and ORP Monitor/controller requires the same care and calibration as your Conductivity/TDS Monitor/controller. With the following Myron L Company NIST traceable buffer solutions it is possible for you to maintain the accuracy required in your process.

**NOTE:** pH and/or ORP Monitor/controllers ORP ZERO is calibrated using 7pH buffer. SPAN may be calibrated using any high quality ORP mV solution.

These same buffers may be used for calibration and recertification of your Myron L or other handheld instrument.

#### a. pH Buffer Solutions

pH buffers are available in pH values of 4, 7 and 10. Myron L Company buffer solutions are traceable to NIST certified pH references and are color-coded for instant identification. They are also mold inhibited and accurate to within ±0.01 pH units @ 25°C. Order 4, 7 or 10 Buffer.

#### b. pH Sensor Storage Solution

Myron L Storage Solution prolongs the life of the pH sensor. It is available in quarts and gallons. Order SSQ, SSG or SS2OZ.

Order example: 442-3000QT  
KCl-7000GAL  
PH10-2OZ

#### C.1.a. Potassium Chloride Standards

KCl-18  
KCl-180  
KCl-1800  
KCl-18,000

KCl-70  
KCl-700  
KCl-7000  
KCl-70,000

#### C.1.b. 442 Natural Water Standards

442-15  
442-150  
442-1500  
442-15,000

442-30  
442-300  
442-3000  
442-30,000

442-500  
442-1000

#### C.1.c. Sodium Chloride Standards

NaCl-12.5  
NaCl-13.4  
NaCl-14.0  
NaCl-7500

#### C.2.a. pH Buffer Solutions

pH4.0  
pH7.0  
pH10.0

#### C.2.b. pH/ORP Storage Solution

SSQ - Quart/liter  
SSG - Gallon  
SS2OZ - 2 oz.

Customer-specific Standard Solutions available by special order. Contact us with your request.

# VII. REPLACEMENT PARTS

## MODEL                      DESCRIPTION

### ELECTRONIC MODULE

#### CONDUCTIVITY

756CB.....	756II Circuit Board Analog Monitor only
757CB.....	757II Circuit Board Analog Monitor/controller
758CB.....	758II Circuit Board Digital Monitor/controller
759CB.....	759II Circuit Board Digital Monitor only

#### RESISTIVITY

751RB.....	751II Circuit Board Analog Monitor only
752RB.....	752II Circuit Board Analog Monitor/controller
753RB.....	753II Circuit Board Digital Monitor/controller
754RB.....	754II Circuit Board Digital Monitor only

(Must select Range Module, see 750II Range Selection Guide)

Add to above model number as shown in example: 751RB-11

#### SPECIAL ORDER OPTIONS

-24VA.....	24 VAC Isolated Power Supply, add to above prices*
-24VD.....	24 VDC Isolated Power Supply, add to above prices*
-HT.....	High Temperature modification for -HT sensors, range limited (contact Myron L tech sales)

**If voltage is not specified, 115/230 VAC will be supplied.**

#### RANGE MODULE - Select from 750II Range Selection Guide

RMXXX.....	Range Module only
RMXXXD.....	With overlay labels for digital models
RMXXXA.....	With overlay labels and meter scale (Dial) for analog models

#### DIGITAL DISPLAY

35.....	31/2 Digit without Bezel
35B.....	31/2 Digit with Bezel (OEM style)*
35BL.....	31/2 Digit Backlit without Bezel
35BLB.....	31/2 Digit Backlit with Bezel (OEM style)*
45BL.....	41/2 Digit Backlit without Bezel
45BLB.....	41/2 Digit Backlit with Bezel (OEM style)*

\* With mounting hardware for ease of panel mounting.

#### ANALOG DISPLAY (Meter Movement) - Specify range, i.e. 0-5000 ppm

50AM (0-XXXX).....	For all panel mounted models, with gasket**
50AMOEM (0-XXXX).....	For all OEM models, with gasket***

\*\* Meter comes with proper scale (Dial) decided by range selected.

\*\*\* Meter comes with proper scale (Dial) decided by range selected and panel insert.

#### HARNESS (Standard 12 in./305 mm)

AH2.....	For 751II & 756II Analog Monitor only
AH.....	For 752II & 757II Analog Monitor/controller
DH.....	For 753II & 758II Digital Monitor/controller
DH2.....	For 754II & 759II Digital Monitor

## VII. REPLACEMENT PARTS Continued

### **ENCLOSURE**

700II ECP ..... 750II Rear Housing (Box) for Picture Frame Front Panel  
 700II ECR ..... 750II Rear Housing (Box) for Roll-off Front Panel

### **FRONT PANEL** with UPPER and LOWER LABELS **Only** (Must select Resistivity or Conductivity type)

**Add "P" for Picture Frame Front Panel style or "R" for Roll-off Front Panel Style, i.e. 751FPR**

751/756FP ..... Analog Front Panel  
 751/756FP-PTS ..... Analog Front Panel with Panel Test Switch label  
 752/757FP ..... Analog Front Panel  
 752/757FP-PTS ..... Analog Front Panel with Panel Test Switch label  
 752/757FP-SC ..... Analog Front Panel with Second Alarm/control label  
 753/758FP ..... Digital Front Panel  
 753/758FP-PTS ..... Digital Front Panel with Panel Test Switch label  
 753/758FP-PA ..... Digital Front Panel with Piezo Alarm  
 753/758FP-SC ..... Digital Front Panel with Second Alarm/control label  
 754/759FP ..... Digital Front Panel  
 754/759FP-PTS ..... Digital Front Panel with Panel Mounted Test Switch label  
 754/758FP-SC-PA ..... Digital Front Panel with Second Alarm label and Piezo Alarm  
 754/758FP-SC-PTS ..... Digital Front Panel with Second Alarm label and Panel Test Switch label  
 754/758FP-SC-PTS-PA ..... Digital Front Panel with Second Alarm label, Panel Test Switch label and Piezo Alarm

### **OPTIONS & ACCESSORIES**

#### **MODEL**

#### **DESCRIPTION**

SCMO ..... Second Alarm/control Module (Monitor/controllers only)  
 SCH ..... Harness, Second Alarm/control  
 4AMO ..... 4-20 mA Self-Powered Isolated Output Module (OEM and digital Monitor/controllers only)  
 4AH ..... Harness, 4A (4-20 mA)  
 PAO ..... 70 db Piezo Electric Alarm only (OEM and digital Monitor/controllers only)  
 PATO ..... Piezo Alarm and Timer Module (OEM and digital Monitor/controllers only)  
 TPMO ..... Temperature Module 0-200°C (OEM and digital Monitor/controllers only)  
 TPAMO ..... Above TP with adjustable hysteresis (special order)  
 TDH ..... Harness, TP and TPA (Temperature Module)  
 TPMH ..... 18 in./457 mm Harness, OEM Temperature Module  
 JM4P ..... Jumper, in place of SC module  
 TPC ..... Calibration Module (Temperature Module)  
 3SMO ..... Module only, 3SO 3 SENSOR Input  
 3RMO ..... Module only, 3RO 3 Range  
 3SRMO ..... Module only, 3SRO 3 SENSOR Input/3 Range  
 3SH ..... Harness, 3SO/3SRO 3 ft./1 meter 5-Wire Sensor Cable  
 3RH ..... Harness, 3RO/3SRO 3 ft./1 meter Multi-Wire Ribbon Cable  
 3SRH ..... Harness, 3SO/3RO/3SRO 3 ft./1 meter 2-Wire Disable Cable  
 RM3R ..... Range Module, 3RMO/3SRMO Resistivity only  
 F100 ..... Fuse, 115/230 VAC control board, 100 mA (T.10A) 5 X 20 slow blow/time delay  
 F250 ..... Fuse, 24 VAC control board, 250 mA (T.25A) 5 X 20 slow blow/time delay  
 024-1 ..... 1 in. NPT 24 VAC Solenoid Valve  
 MCRD-(length) ..... Cable, 5-Wire Sensor Cable (~ \$2.50/meter)  
 RAH ..... Harness, female Methode connector with 8 in./203 mm 2 conductor wire.  
 For use with RA, PA, 3S (Flow Switch), etc.

## VIII. WARRANTY

All Myron L Company Conductivity/TDS and Resistivity Monitor/controllers have a **TWO** Year Limited Warranty. If any Monitor/controller or sensor fails to function normally, return the faulty unit to the factory prepaid. If, in the opinion of the factory, failure was due to materials or workmanship, repair or replacement will be made without charge.

A reasonable service charge will be made for diagnosis or repairs due to normal wear, abuse or tampering. Warranty is limited to the repair or replacement of Monitor/controller or sensor only. The Myron L Company assumes no other responsibility or liability.

**MYRON L COMPANY**  
**2450 Impala Drive**  
**Carlsbad, CA 92010-7226**  
**USA**  
**Tel: +1-760-438-2021**  
**Fax: +1-760-931-9189**

**E-Mail: [info@myronl.com](mailto:info@myronl.com)**  
**[techquestions@myronl.com](mailto:techquestions@myronl.com)**

**[www.myronl.com](http://www.myronl.com)**

## ADDITIONAL INFORMATION

Custom Monitors/controllers available, contact us with your special needs. Price and delivery upon request.

**ALL SPECIAL ORDER ITEMS ARE NON-RETURNABLE AND NON-REFUNDABLE.**

Because of our policy of continuous product improvement, the Myron L Company reserves the right to make changes in design, specifications, and prices without notice.

Minimum order \$25.00. All prices are US dollars and are F.O.B. Carlsbad, CA. USA.

Terms: 1% 10 days, net 30 days upon approved credit.

Credit Cards accepted: Visa, MasterCard, and American Express.

## IX. GLOSSARY

<b>442™</b>	An Internationally recognized “natural water” standard developed by the Myron L Company in 1964.
<b>Algorithm</b>	A procedure for solving a mathematical problem. See Addendum, Temperature Compensation and TDS Derivation.
<b>Anions</b>	Negatively charged ions
<b>DVM</b>	Digital Volt Meter
<b>Hysteresis</b>	Dead Band — related to alarm setpoint. The amount of delay or overlap between change from high to low or low to high.
<b>LCD</b>	Liquid Crystal Display
<b>KCl</b>	Potassium Chloride — used as a standard for many applications. Normally, micromhos or microsiemens are the units of measure.
<b>NaCl</b>	Sodium Chloride — used as a standard for sea water and other applications.
<b>NIST</b>	National Institute Standards & Testing
<b>PLC</b>	Programmable Logic Controller
<b>PPM</b>	Parts Per Million — common units of measure for TDS.
<b>PPT</b>	Parts Per Thousand — common units of measure for TDS.
<b>SCADA</b>	Supervisory Control And Data Acquisition
<b>Tempco (TC)</b>	Temperature Compensation — See Addendum, Temperature Compensation.
<b>TDS</b>	Total Dissolved Solids or the Total Conductive Ions in a solution — normally displayed as ppm or ppt. See Addendum, Conductivity Conversion to TDS.
<b>Tweaker</b>	A screwdriver specially designed for adjusting electrical calibration controls.
<b>μM or μS</b>	Micromho or microsiemen — common unit of measure for conductivity.
<b>MegΩ</b>	Megohm — common unit of measurement for resistivity.
<b>USP25</b>	United States Pharmaceutical regulation, revision number 25. In part, requires Conductivity/TDS, resistivity or pH measurements be taken, recorded and/or systems controlled using equipment without temperature compensation. Requires a separate temperature measuring device (temperature measurements may be part of Cond/TDS, Resistivity or pH device but must not correct measurements for temperature errors).

## X.NOTES

# XI. ADDENDUM

## A. CONDUCTIVITY, TDS AND TEMPERATURE RELATIONSHIPS

### 1. TEMPERATURE COMPENSATION (Tempco) of Aqueous Solutions

Electrical conductivity indicates solution concentration and ionization of the dissolved material. Since temperature greatly affects ionization, conductivity measurements are temperature dependent and are normally corrected to read what they would be at 25°C.

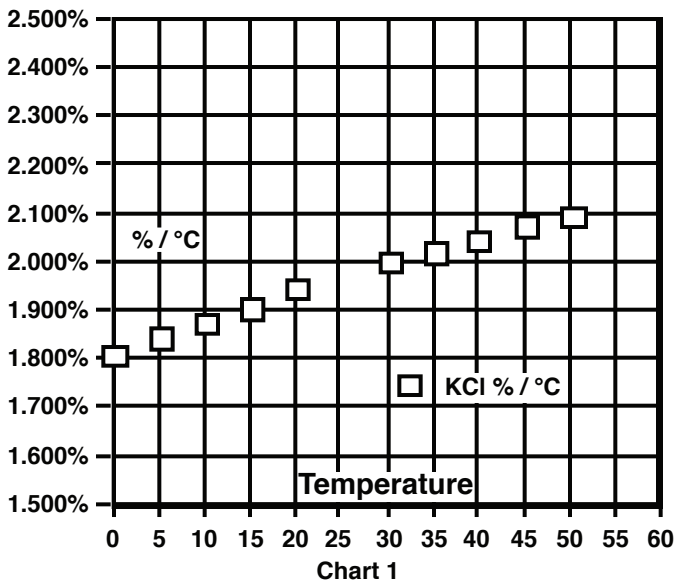
#### a. Standardized to 25°C

Conductivity is accurately measured in the 750II by a method that ignores electrolysis, electrode characteristics, etc., and uses a unique circuit to perform temperature compensation. In simpler instruments, conductivity values are usually assigned an average correction similar to KCl solutions for correction to 25°C. The correction to an equivalent KCl solution is a standard set by chemists. It standardizes the measurements and allows calibration with precise KCl solutions recognized for stability.

#### b. Tempco Variation

Most conductivity instruments use an approximation of the temperature characteristics of solutions, perhaps even assuming a constant value. The value for KCl is often quoted simply as 2%/°C. In fact, KCl tempco varies with concentration and temperature in a non-linear fashion. Other solutions have more variation still. The 750II uses corrections that change with concentration and temperature instead of single average values.

#### c. An Example of 2 different solution selections and the resulting compensation:



The 750II will provide the repeatability of data needed for relative values for process control.

### 2. CONDUCTIVITY CONVERSION to TOTAL DISSOLVED SOLIDS (TDS)

Electrical conductivity indicates solution concentration and ionization of the dissolved material. Since temperature greatly affects ionization, conductivity measurements are temperature dependent and are normally corrected to read what they would

be at 25°C (ref. Temperature Compensation).

#### a. How it's Done

Once the effect of temperature is removed, the compensated conductivity is a function of the concentration (TDS). Temperature compensation of the conductivity of a solution is performed automatically by the electronic circuit, using data derived from chemical tables. Any dissolved salt at a known temperature has a known ratio of conductivity to concentration. Tables of conversion ratios referenced to 25°C have been published by chemists for decades.

#### b. Solution Characteristics

Real world applications have to measure a wide range of materials and mixtures of electrolyte solutions. To solve this problem, industrial users commonly use the characteristics of a standard material as a model for their solution, like the KCl favored by chemists for its stability.

Users dealing with sea water, etc., commonly use NaCl as the model for their concentration calculations. Users dealing with freshwater work with mixtures including sulfates, carbonates and chlorides, the three predominant components (anions) in freshwater that Myron L Company calls "natural water". These are modeled in a mixture called "442™" which the Myron L Company developed and markets for use as a calibration standard, as it does standard KCl and NaCl solutions.

#### c. When does it make a lot of difference?

First, the accuracy of temperature compensation to 25°C determines the accuracy of any TDS conversion. Assume we have industrial process water to be pretreated by RO. Assume it is 45°C and reads 1500 μS uncompensated.

1. If NaCl compensation is used, an instrument would report 1035 μS compensated, which corresponds to 510 ppm NaCl.

2. If 442 compensation is used, an instrument would report 1024 μS compensated, which corresponds to 713 ppm 442.

The difference in values is 40%.

In spite of such large error, some users will continue to take data in the NaCl mode because their previous data gathering and process monitoring was done with an older NaCl referenced device.

Those who want true TDS readings that will correspond to evaporated weight will select the correct Solution Type.

### 3. TEMPERATURE COMPENSATION (Tempco) and TDS DERIVATION

When making conductivity measurements, the Solution Selection determines the characteristic assumed as the instrument reports what a measured conductivity would be if it were at 25°C. The characteristic is represented by the tempco, expressed in %/°C. If a solution of 100 μS at 25°C increases to 122 μS at 35°C, then a 22% increase has happened over this change of 10°C. The solution is said to have a tempco of 2.2 %/°C.

Another solution would have a different tempco because of its ionization activity. And, that tempco may be a little different at a different concentration or temperature.

**XI. ADDENDUM Continued**



## **XI. ADDENDUM Continued**

**XI. ADDENDUM Continued**

**MYRON L COMPANY**  
2450 Impala Drive  
Carlsbad, CA 92010-7226  
USA  
Tel: +1-760-438-2021  
Fax: +1-760-931-9189

**E-Mail: [info@myronl.com](mailto:info@myronl.com)  
[techquestions@myronl.com](mailto:techquestions@myronl.com)**

**[www.myronl.com](http://www.myronl.com)**

**Made in USA**

**ACCURACY • RELIABILITY • SIMPLICITY**

**MYRON L  
COMPANY**  
Water Quality Instrumentation  
*Accuracy • Reliability • Simplicity*