

Magnetic Drive Gear Pump

SERIES 200

Series 200 Micropump's Series 200 magnetic

drive gear pump features a patented suction shoe design that delivers the high performance needed to keep your operations flowing smoothly. The unique design self compensates for wear, ensuring near zero slip and a longer pump life. Available in standard or custom configurations, Series 200 pumps offer the flexibility to meet a wide range of applications with a compact size, options like two standard gear sizes, an internal bypass, and variety of materials.



Small Size

The miniature package size of the Series 200 delivers performance that is usually found only in much larger pumps.

Leak-Free

The magnetic drive and a single O-ring seal keep the fluid securely inside the pump and potential contaminants out.

Smooth Pulseless Delivery

Positive displacement, helical gears provide smooth, accurate fluid delivery that is proportional to motor speed.

Chemically Resistant

An extensive range of wetted material options ensure compatibility with a wide range of chemicals.

Easy to Service

Series 200 pumps are easy to service using a Micropump service kit and simple hand tools.

Wide Range of Options

Product design offers the flexibility to configure the product to your specific needs. Some options include:

- Two standard gear sizes
- Two and three gear versions
- Multiple gear, body, and O-ring materials
- Optional internal bypass
- Two standard port sizes
- Optional high torque magnets
- NEMA, IEC, and Micropump drive mounts

Advanced Pump Technology

Micropump uses the latest engineering tools and manufacturing equipment to produce the most advanced pumping solutions available. Products are developed using state-of-the-art CAD, Finite Element Analysis (FEA), and rapid prototyping tools.

Precision CMM and CNC manufacturing equipment ensure the highest level of product quality.

Proven Reliability

Over 40 years of experience solving the most difficult pumping problems go into the design and manufacture of every Micropump pump, ensuring the most reliable pumping solution available.

OEM Configurations

Series 200 pumps can be customized to meet your individual requirements.



SERIES 200

Magnetic Drive Gear Pump

Performance Summary

Flow Rate			
at 3450 rpm			
4.0 L/min		1.1 gpm	
Displacement (ml/rev)			
Gear Set	P23	P25	P35
ml/rev	0.26	0.58	1.17
Maximum Differential Pressure			
8.7 Bar		125 psi	
Maximum System Pressure			
21 Bar		300 psi	
Temperature Range			
-46 to 177° C		-50 to 350° F	
Viscosity Range		Maximum Speed	
0.2 to 1500 cps		10,000 rpm	

Dimensions

"A" Mount

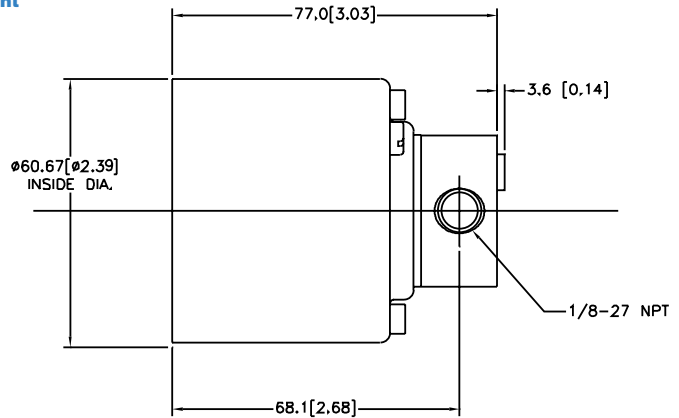

Units: mm[in]. Nominal dimensions shown.

Pump Construction

- Magnetic drive gear pump
- Suction shoe style
- Two or three helical gears
- Stationary shafts
- O-ring seal

Wetted Materials

- Base material
 - 316 stainless steel
 - Alloy 20
 - Titanium
 - Hastelloy C-276®
 - Hastelloy B-2®
- Gear material
 - PEEK
 - Ryton® (PPS)
- Static seals
 - Viton®
 - Ethylene propylene
 - Buna N
 - Kalrez®

Magnets

- Driven and driving
 - Ferrite
 - Rare earth

Product Enhancements

- Internal bypass
- 1/4-18 NPT ports
- Tri-clamp fittings

Pump Performance

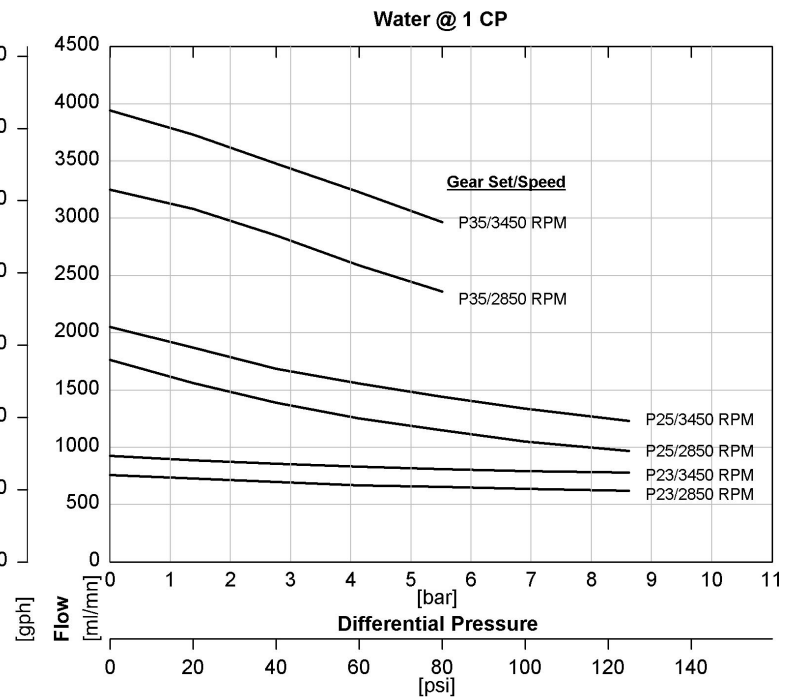

Order Code

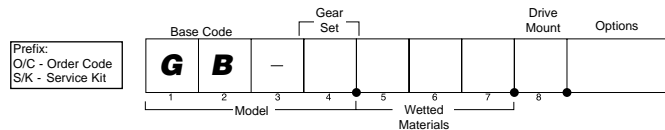

ACTUAL PERFORMANCE MAY VARY

Specifications are subject to change without notice.

©2001 Micropump, Inc., A Unit of IDEX Corporation
Micropump and the Micropump logo are registered trademarks of Micropump, Inc. All other trademarks belong to their respective owners.

TT2753MPV-05/2001

MICROPUMP, INC.

A Unit of IDEX Corporation

Phone: (360) 253-2008 • (800) 671-6269
Fax: (360) 253-2401 • (800) 222-9565

MICROPUMP LIMITED

A Subsidiary of Micropump, Inc.

Phone: + 44 (0) 1480 356900
Fax: + 44 (0) 1480 356920

info@micropump.com
www.micropump.com

