

## WARRANTY

*Use only MASTERFLEX precision tubing with MASTERFLEX pumps to ensure optimum performance. Use of other tubing may void applicable warranties.*

The Manufacturer warrants this product to be free from significant deviations from published specifications. If repair or adjustment is necessary within the warranty period, the problem will be corrected at no charge if it is not due to misuse or abuse on your part, as determined by the Manufacturer. Repair costs outside the warranty period, or those resulting from product misuse or abuse, may be invoiced to you.

*The warranty period for this product is noted on the warranty card.*

## RETURN OF ITEMS

To limit charges and delays, contact the seller or Manufacturer for authorization and shipping instructions before returning the product, either within or outside of the warranty period. When returning the product, please state the reason for the return. For your protection, pack the product carefully and insure it against possible damage or loss. Any damages resulting from improper packaging are your responsibility.

## TECHNICAL ASSISTANCE

If you have any questions about the use of this product, contact the Manufacturer or authorized seller.



### Cole-Parmer Instrument Co.

625 East Bunker Court  
Vernon Hills, Illinois U.S.A. 60061-1844  
1-800-MASTERFLEX (627-8373) (U.S. and Canada only)  
11 (847) 549-7600 (outside U.S.)  
(847) 549-7600 (Local)  
FAX (847) 247-2929 (U.S. and Canada only)  
11 (847) 549-1700 (Fax outside U.S.)  
www.masterflex.com  
e-mail: techinfo@coleparmer.com



### Barnant Company

28W092 Commercial Ave.  
Barrington, Illinois U.S.A. 60010-2392  
1-800-637-3739 (U.S. and Canada only)  
11 (847) 381-7050 (outside U.S.)  
(847) 381-7050 (Local)  
11 (847) 381-7053 (Fax outside U.S.)  
(847) 381-7053 (Local Fax)  
www.barnant.com  
e-mail: barnant@barnant.com



## OPERATING MANUAL

# MASTERFLEX® I/P®

## HIGH PERFORMANCE PUMP HEAD

### Model 77600-62

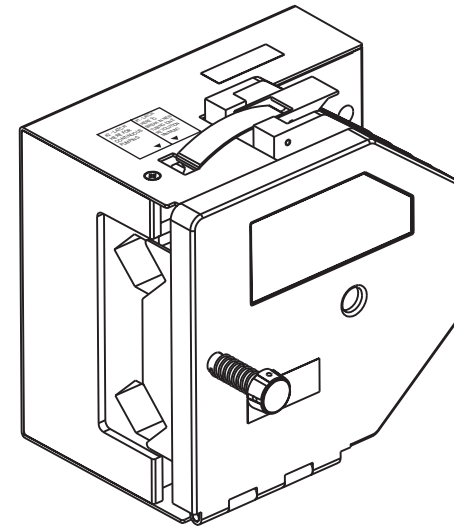

### Cole-Parmer Instrument Co.

1-800-MASTERFLEX (627-8373) (U.S. and Canada only)  
11 (847) 549-7600 (outside U.S.)  
(847) 549-7600 (Local)  
www.masterflex.com

### Barnant Company

1-800-637-3739 (U.S. and Canada only)  
11 (847) 381-7050 (outside U.S.)  
(847) 381-7050 (Local)  
www.barnant.com

## SAFETY PRECAUTIONS

**WARNING:** Turn drive off before removing or installing tubing. Fingers or loose clothing could be caught in the rollers.



### **WARNING: PRODUCT USE LIMITATION**

This product is not designed for, nor intended for use in patient connected applications; including, but not limited to medical and dental use and accordingly, has not been submitted for FDA approval.

**NOTE:** Use only MASTERFLEX® precision tubing with MASTERFLEX® pumps to ensure optimum performance. Use of other tubing may void applicable warranties.

## EXPLANATION OF SYMBOLS



**CAUTION: Risk of danger.** Consult the Operator's Manual for nature of hazard and corrective actions.



**CAUTION: Risk of crushing.** Keep fingers away from rotor while pump is in operation. Stop pump before loading or unloading tubing.

## MAINTENANCE

Maintenance is limited to replacement of the parts listed in the replacement parts list and cleaning the pump head.

### Replacement Parts

REF	DESCRIPTION	ORDER NUMBER
A	Rotor/Body Kit	77600-69
B	Tubing Retainer Kit	77600-66
C	Occlusion Bed Assembly Kit	77600-67
D	Tang Boot	77600-02
E	Mounting Screws (not shown)	77600-01

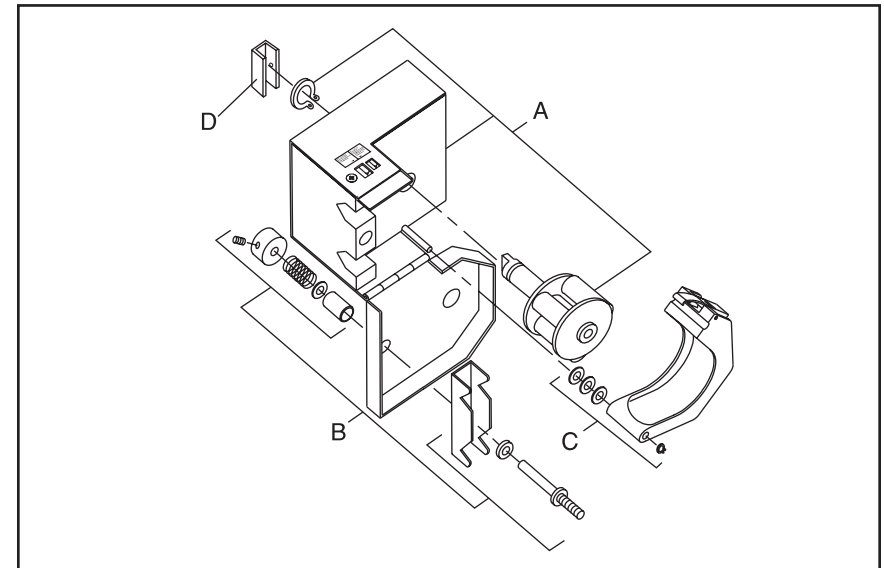

**Figure 4. Exploded View Pump**

**NOTE:** Inspect the tang boot after 2000 hours of operation and replace if necessary.

### Cleaning Pump Head

Use mild detergent with water to clean the pump and rotor assembly. Do not immerse nor use excessive fluid.

## INTRODUCTION

The MASTERFLEX® I/P® High Performance Pump Head delivers in excess of 17 L/min flow at normal MASTERFLEX operating speeds and pressures. It is designed for optimal pumping in the clockwise direction. There are two mounting positions. Tubing entry and exit are either on the left side or on top of the pump when mounted on a MASTERFLEX® I/P® drive. The pump will operate with any MASTERFLEX® I/P® drive that accepts two or more Pump Heads. However, maximum operating pressure depends on the drive and tubing material selected, as shown below.

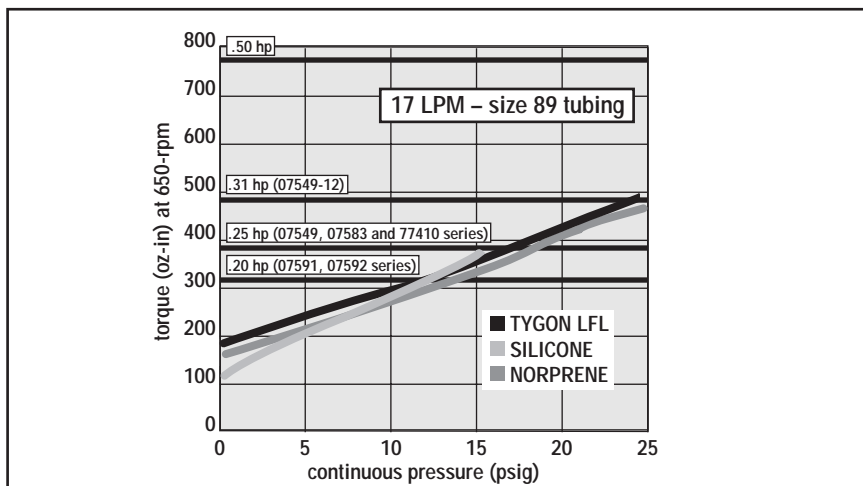

## SETUP AND OPERATION

### Pump Drive Compatibility

The High Performance Pump Head has a standard shaft interface to accommodate MASTERFLEX® I/P® Pump Drives.

### Mounting Pump Head to Drive

1. Check that pump drive is turned OFF.
2. Make sure the plastic tang boot (see Figure 4) is installed on the pump shaft tang. (Operation without the boot could cause damage to the pump shaft.)
3. Align pump shaft tang with slot in motor shaft.
4. Secure pump to pump drive with the four mounting screws (furnished).
  - a. For left side tubing entry and exit, use round mounting holes.
  - b. For top tubing entry and exit, use hexagonal mounting holes.
  - c. When using MASTERFLEX console drives, 07549 series, mount the pump according to Figure 1. Use the holes labeled "A" for left tubing entry/exit orientation; use holes labeled "B" for top entry/exit orientation.

### Selecting Tubing

Pumps accept only I/P® 70, I/P® 88 and I/P® 89 tubing. Use only MASTERFLEX tubing which is surface printed with the tubing designation.

Figure 1. Mounting Holes for Console Drive, 07549 Series

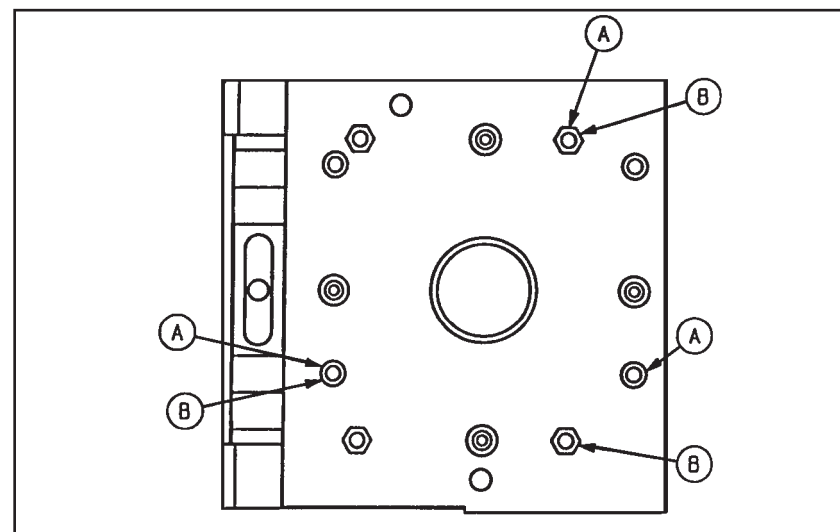

### Loading Tubing

**WARNING: Turn drive off before removing or installing tubing. Fingers or loose clothing could be caught in the rollers.**



1. Rotate tubing retainer knob, Figure 2, counterclockwise to release retainer, then pull to open cover.
2. Lift latch to open occlusion bed.

Figure 2. High Performance Pump Head

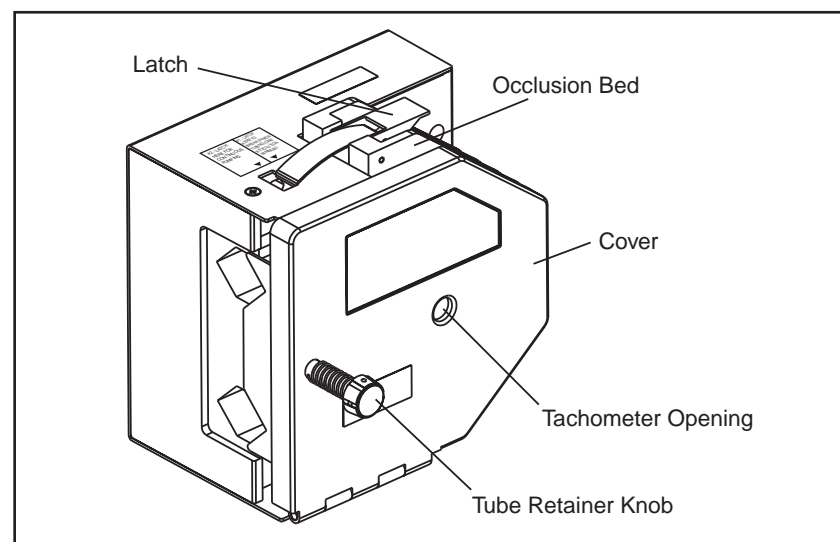

3. Insert the MASTERFLEX tubing inside tubing guide and around rotor with the ends of the tubing extending out the tubing entrance and tubing exit as shown in Figure 3. Position tubing on center of roller.
4. Press the occlusion bed against the tubing and snap the latch closed, using latch slot 1 as shown in Figure 3.
5. Close the cover, and then pull the tubing snug (do not stretch) around the rotor assembly.
6. Tighten the tubing retainer by rotating the tubing retainer knob clockwise sufficiently to prevent the tube from moving.
7. Start the drive. Let the pump rotor turn at least one revolution to break in the tubing, before turning off the drive.
8. Unlatch the bed from slot 1, and relatch using slot 2. Pump is now ready for operation.

**Figure 3. Loading Tubing**

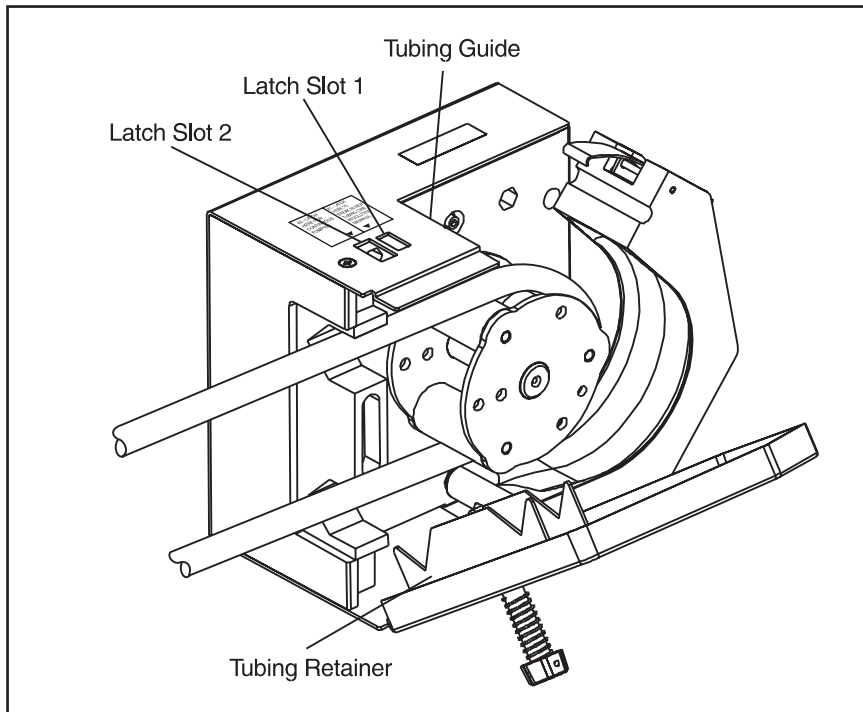

### Operation

1. Connect pump tubing to desired source and destination.
2. Start pump drive and set desired speed.

## SPECIFICATIONS

Pump Head number	Pump Material	Occlusion	Shaft Length	I/P* Tubing
77600-62	PE/SS	Fixed	Short	I/P * 70,88,89

### Typical Flow, Pressure and Vacuum Data, (CW Direction):

I/P * Tubing	Flow rate		Discharge Pressure*		Vacuum* @ 650 rpm in (mm) Hg	Suction Lift* @ 650 rpm ft (m) H <sub>2</sub> O
	@20 rpm L/min	@ 650 rpm L/min	Continuous psig (bar)	Intermittent psig (bar)		
I/P * 70	.26	8	25 (1.7)	40 (2.7)	26 (660)	29 (8.8)
I/P * 88	.40	13	20 (1.4)	35 (2.4)	26 (660)	29 (8.8)
I/P * 89	.52	17	15 (1.0)	20 (1.4)	24 (610)	27 (8.3)

<b>Number of rollers:</b>	3
<b>Occlusion:</b>	Fixed
<b>Maximum pump speed (rpm):</b>	650
<b>Nominal torque load-running:</b>	up to 600 oz-in (43 kg-cm)
<b>Housing materials:</b>	Stainless steel (SS), polyester (PE) body and tubing bed, polypropylene (PP) knob
<b>Roller/bearing materials:</b>	Stainless Steel (SS)/Sealed Stainless Steel
<b>Rotor materials:</b>	Stainless Steel (SS)
<b>Operating Temperature<sup>‡</sup>:</b>	32°F to 104°F (0°C to 40°C)
<b>Storage Temperature:</b>	-40°F to 149°F (-40°C to 65°C)
<b>Humidity:</b>	5% to 95% (non-condensing)
<b>Dimensions (W x H x D):</b>	
Operating:	7.5 in x 7.0 in x 6.0 in (191 mm x 178 mm x 152 mm)
Open:	8.7 in x 7.0 in x 10.0 in (221 mm x 178 mm x 254 mm)
<b>Weight:</b>	8 lb (3.63 kg)

\* As tested with NORPRENE®, PHARMED®, and TYGON® tubing. Values will be less with silicone and C-FLEX®.

‡ Use in this temperature range for continuous duty operation with no decrease in performance or product life. Pump heads will work outside this range with some possible reductions in performance or product life.