

V.A.R. MODEL NUMBERS

975-2500
975-2800

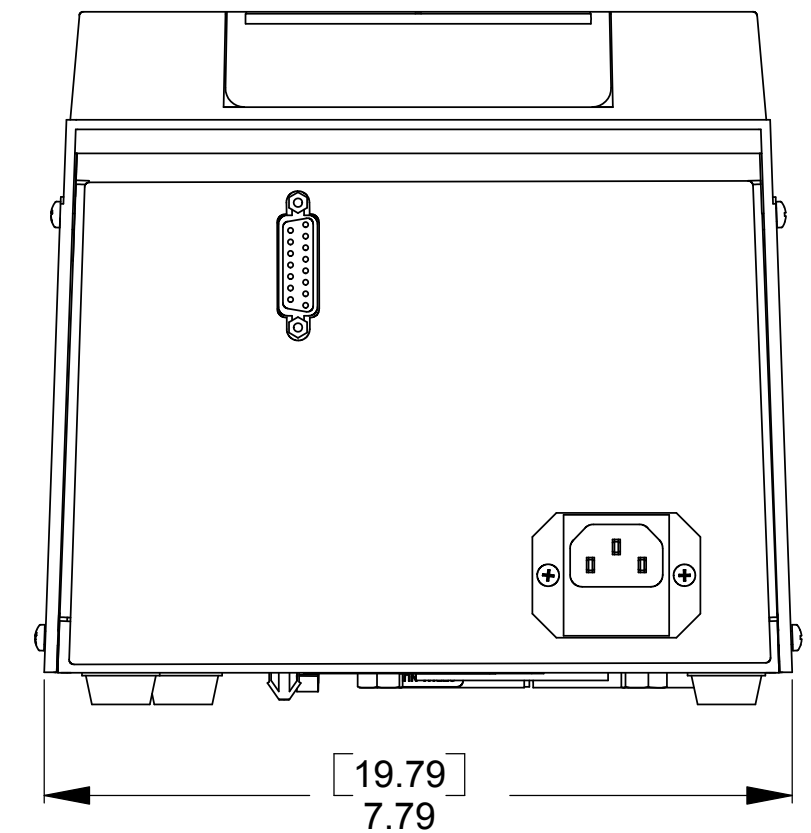
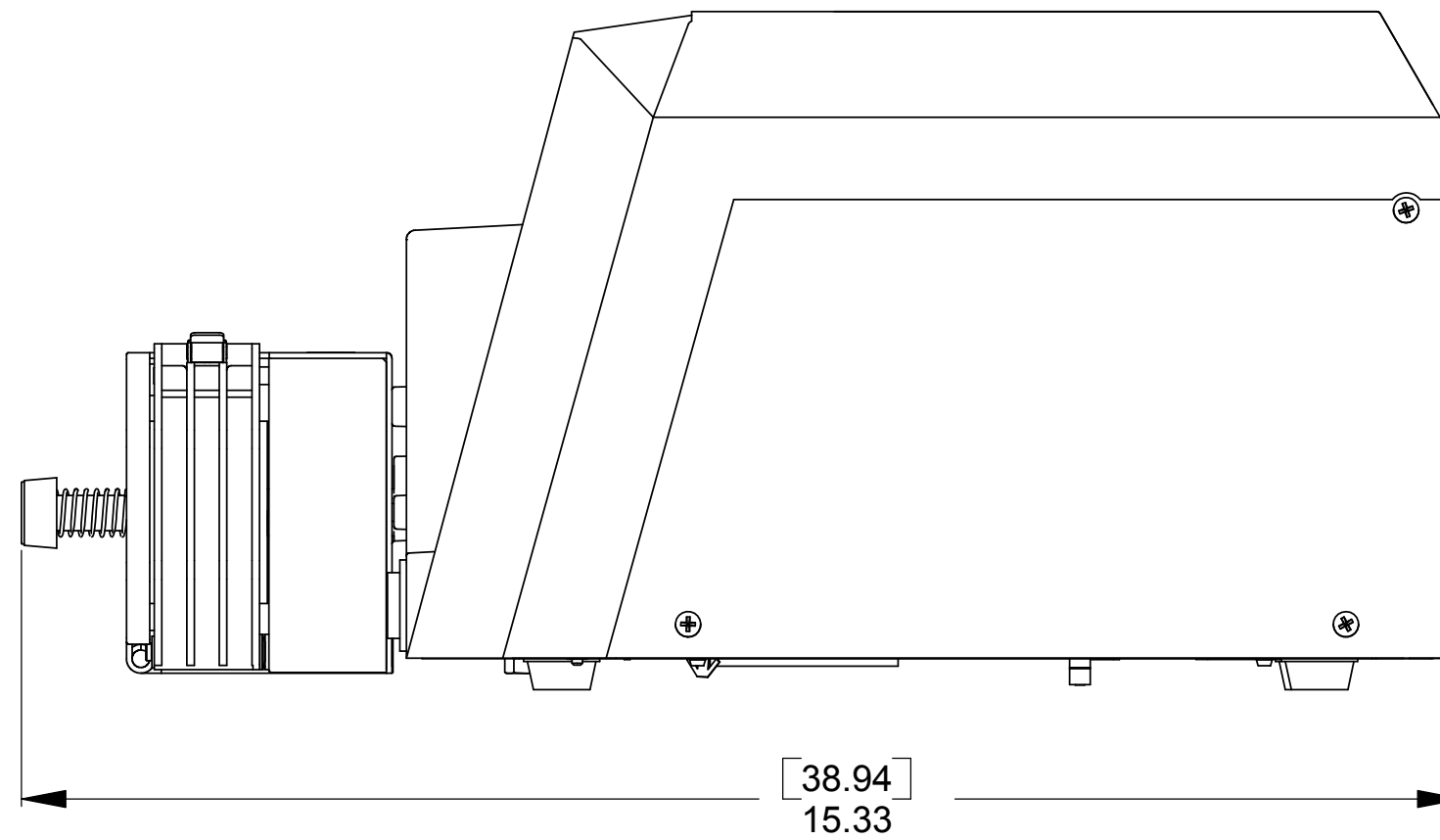
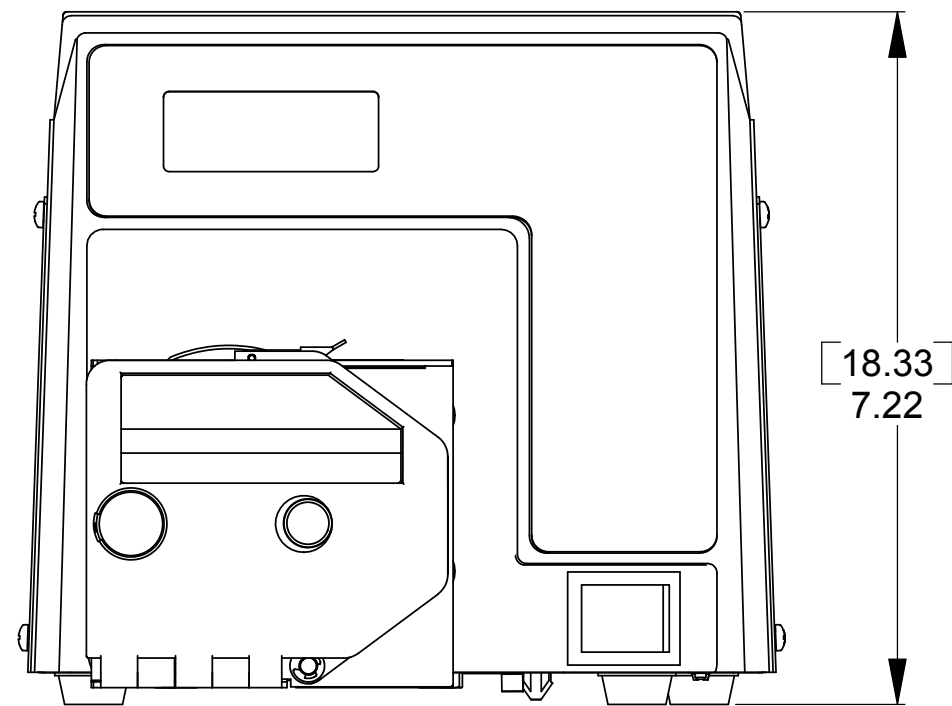
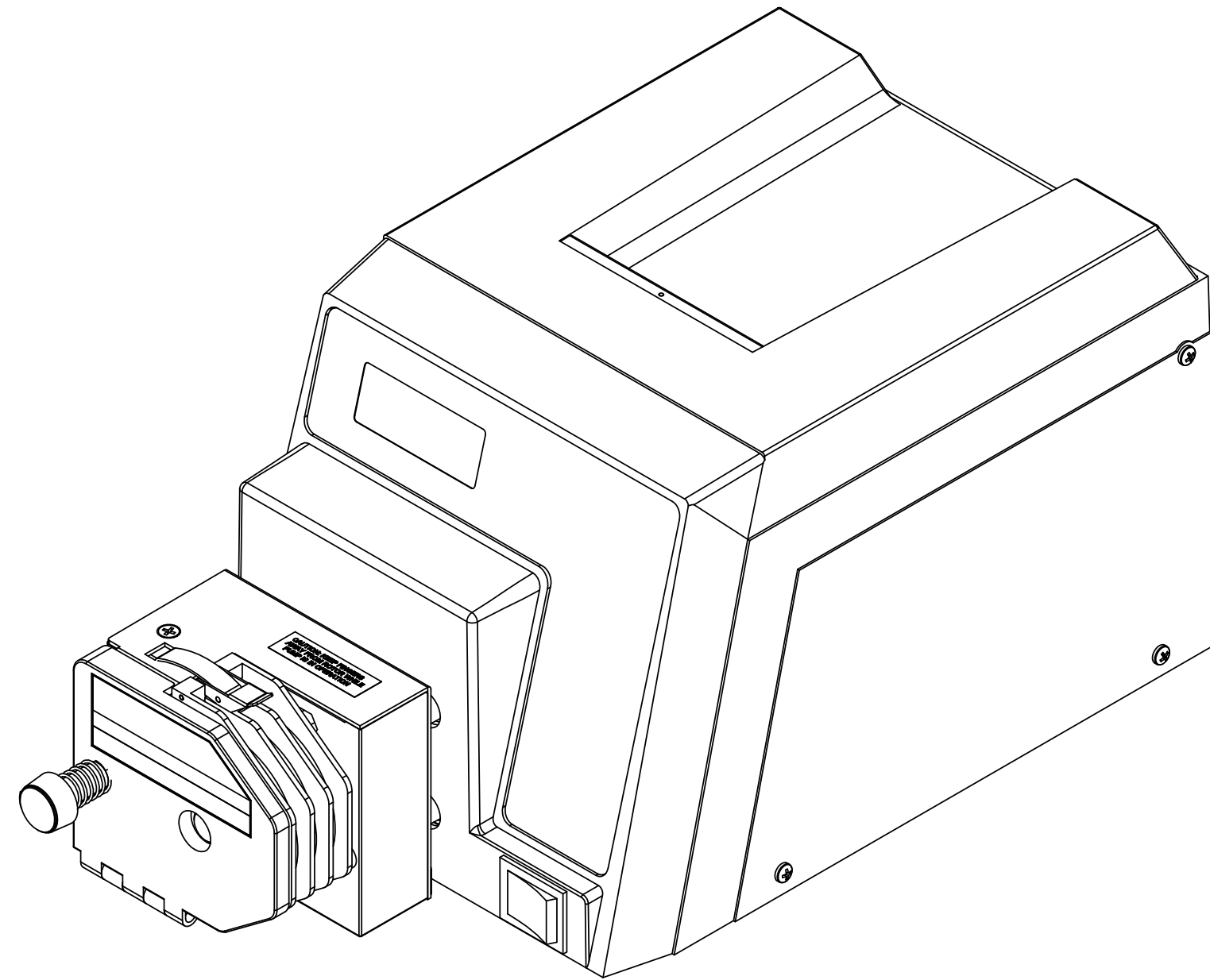

2. ALL DIMENSIONS ARE IN INCHES (CM)

1. ALL DIMENSIONS ARE APPROXIMATE

NOTE:

THESE COMMODITIES, TECHNOLOGY OR SOFTWARE IF EXPORTED FROM THE UNITED STATES WILL BE DONE SO IN ACCORDANCE WITH EXPORT ADMINISTRATION REGULATIONS DIVERSION CONTRARY TO U.S. LAW PROHIBITED.

THE INFORMATION CONTAINED IN THIS DRAWING IS THE SOLE PROPERTY OF THE BARNANT COMPANY. ANY REPRODUCTION IN PART OR WHOLE WITHOUT THE WRITTEN PERMISSION OF THE BARNANT COMPANY IS PROHIBITED.

DATE DRAWN: 04/14/06
DRAWN BY: J.MERKIN

UNLESS OTHERWISE SPECIFIED:
DIMENSIONS ARE IN INCHES.
TOLERANCES ARE:
XX ±.01
XXX ±.005
ANGLES ±1/2°
MACHINED PARTS TO BE 125RMS

Barnant
Barnant Company, 28W092 Commercial Avenue
Barrington, Illinois 60010-2392 (847)-381-7050

CHECKED BY: JJS
APPROVED BY: GJ

MATERIAL: NA
CERTIFICATION OF CONFORMITY/ COMPLIANCE REQUIRED MATERIAL FINISH SOURCE CONTROLLED

SCALE: 1:2

PART NAME: **OUTLINE, DWG C'SL DRV LS HP PMP**

REV	DESCRIPTION	ECN/PRM	DATE	REV	DESCRIPTION	ECN/PRM	DATE	PART No.	PROCESS/FINISH/ MODEL No.
A	RELEASED FOR PRODUCTION	14595	04/13/06						

DO NOT SCALE DRAWING **C** SHEET 1 of 1 DRAWING NUMBER: 108271