



PART NUMBER: L4818

SERVICE INSTRUCTIONS: L4818

REVISION			
LTR.	DESCRIPTION	DATE	BY
C	UPDATED DRAWING	3/28/00	DHA

MOD: 5500

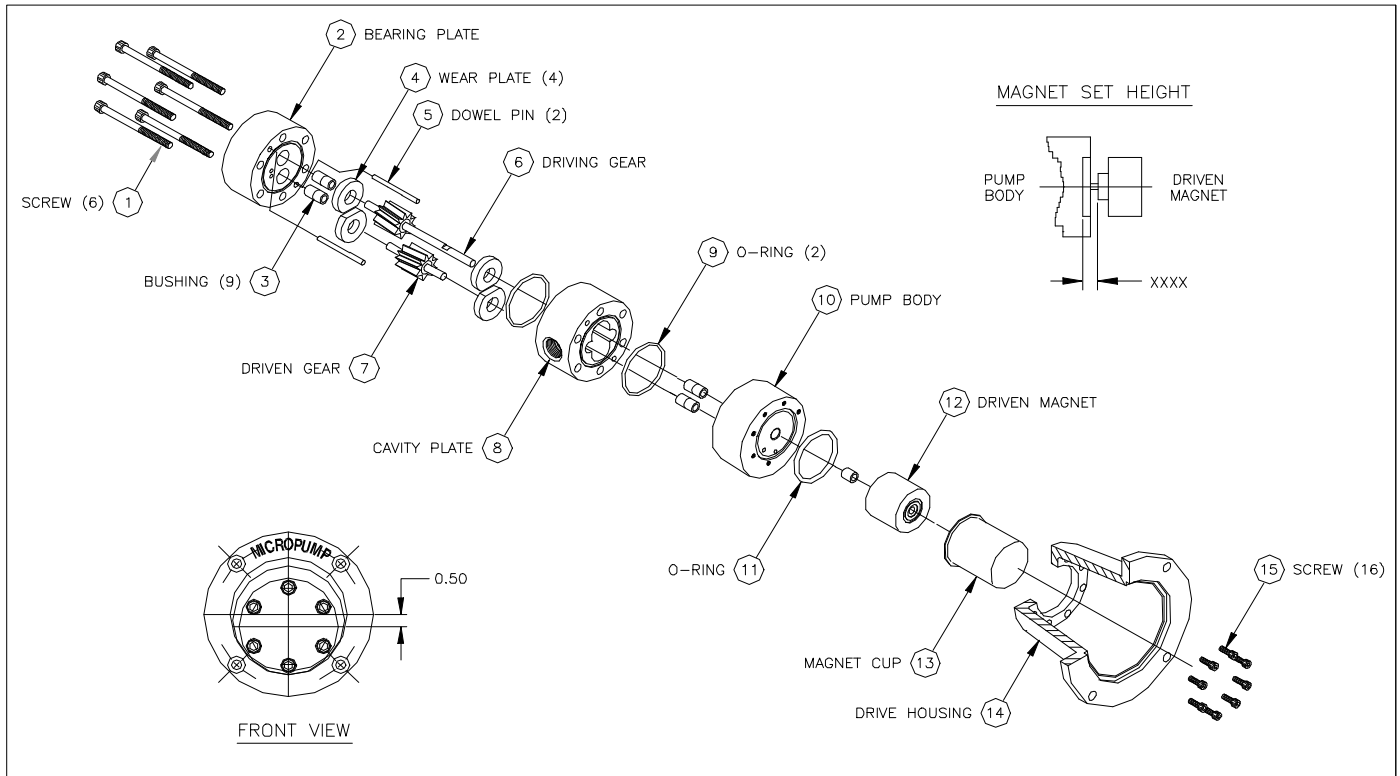

FIGURE 1

1. Description and Operation

1.1 The Model 5500 pump is a positive displacement gear pump constructed of 316 stainless steel, PEEK or Teflon, and Viton.

Special pumps may be constructed of alternate materials. The pump is magnetically driven and is therefore leak-proof and contamination free. The pump is self priming under normal conditions.

1.2 Drive power for the pump is provided by the motor via the magnetic coupling. An exploded view is shown in Figure 1. Fluid is drawn into the pump due to the negative pressure created by the gear rotation in the cavity plate. The fluid is contained by the gear teeth, cavity walls, and gear mesh to create fluid transfer and pressure.

MICROPUMP, INC.

A Unit of IDEX Corporation

PO Box 8975, Vancouver, WA 98668-8975 • Phone: 360/253-2008 • Fax: 360/253-8294

MICROPUMP LIMITED

A Subsidiary of Micropump, Inc.

Howard Road, Eaton Socon, St. Neots, Cambridgeshire, PE 19 3ET England, • Phone: (44) (0) 1480-356600 • Fax: (44) (0) 1480-356300

REVISION			
LTR.	DESCRIPTION	DATE	BY
C	UPDATED DRAWING	3/28/00	DHA

2. Tools and materials required for Disassembly, Repair, and Assembly of Pump

- 2.1 Hex Keys (9/64", 3/16", and 5/16")
- 2.2 X-Acto knife (or equivalent)
- 2.3 Masking Tape
- 2.4 Surface plate or equivalent flat surface
- 2.5 Bushing insertion tool (or arbor press)
- 2.6 Reamer for bushings
- 2.7 Silicone vacuum Grease
- 2.8 Stoddard Solvent or liquid detergent

3. Disassembly of Pump (Refer to Figure 1)

Note: Prepare a clean, flat area, free of metal particles.

- 3.1 Place pumphead on surface with housing facing up.

**NOTE: EXERCISE CAUTION IN THE FOLLOWING STEP.
ENTRAPPED FLUID WILL BE RELEASED WHEN PUMP BODY
AND MAGNET CUP ARE SEPARATED.**

- 3.2 Remove the screws (15), qty 16 (Qty 8 for low pressure version), and pull the drive housing (14) and magnet cup (13) from the pump body (10).
- 3.3 Separate magnet cup (13) and drive housing (14).
- 3.4 Loosen the setscrew on the driven magnet (12) and remove magnet from driving gear (6) shaft.

Note: Store the driven magnet (12) in a clean bag and keep away from other magnets and sensitive electronic equipment.

- 3.5 Remove screws (1), qty 6, and pull bearing plate (2), cavity plate (8), and three of the dowel pins (5) straight away from pump body (10).
- 3.6 Separate bearing plate (2), cavity plate (8), and two dowel pins (5) from each other. Gently lift the wear plates (4) (if used), qty 4, out of the cavity plate (8), taking care to pull them straight out.

MICROPUMP, INC.

A Unit of IDEX Corporation

PO Box 8975, Vancouver, WA 98668-8975 • Phone: 360/253-2008 • Fax: 360/253-8294

MICROPUMP LIMITED

A Subsidiary of Micropump, Inc.

Howard Road, Eaton Socon, St. Neots, Cambridgeshire, PE 19 3ET England, • Phone: (44) (0) 1480-356600 • Fax: (44) (0) 1480-356300

PART NUMBER:	L4818
--------------	-------

REVISION			
LTR.	DESCRIPTION	DATE	BY
C	UPDATED DRAWING	3/28/00	DHA

Note: If dowel pins are difficult to remove, protect pins with a soft material (i.e. plastic or rubber) and remove them with pliers. Replace pins if damaged.

- 3.7 Remove driving gear (6) and driven gear (7) from pump body (10).
- 3.8 See repair instructions, section 6.5.1 regarding bushing (3), qty 9, removal.

Note: Remove bushings and O-rings ONLY if replacement is necessary.

4. Inspection of Pump Components

4.1 Magnet Cup (10)

- 4.1.1 Visually check the outside of the magnet cup (13) for rub marks on the back and sides. Marks on the back indicate that the hub assembly is misaligned axially. Marks on the sides indicate radial misalignment.
- 4.1.2 Visually check the inside surfaces of the magnet cup (13) for rub marks. Marks on the bottom surface indicate that either the driven magnet (12) or hub assembly is misaligned. See section 7.12 for driven magnet (12) installation. See section 8.1 for hub assembly installation. Marks on the insides of the magnet cup (13) indicate radial misalignment of the driven magnet (12), refer to section 6.2.

4.2 Driven Magnet (12)

- 4.2.1 Visually check the driven magnet (12) for wear on the outside shell; refer to section 6.2.
- 4.2.2 Visually check the driven magnet (12) for metal particles. See cleaning instructions, section 5.

4.3 Driving gear (6) and driven gear (7)

- 4.3.1 Visually check the gear teeth on both gears for pits, wear, or damage.
Replace both gears if either gear is damaged or worn.

MICROPUMP, INC.

A Unit of IDEX Corporation

PO Box 8975, Vancouver, WA 98668-8975 • Phone: 360/253-2008 • Fax: 360/253-8294

MICROPUMP LIMITED

A Subsidiary of Micropump, Inc.

Howard Road, Eaton Socon, St. Neots, Cambridgeshire, PE 19 3ET England, • Phone: (44) (0) 1480-356600 • Fax: (44) (0) 1480-356300

PART NUMBER:	L4818
--------------	-------

REVISION			
LTR.	DESCRIPTION	DATE	BY
C	UPDATED DRAWING	3/28/00	DHA

4.3.2 Visually check gear shafts for wear, pits, scoring, or corrosion. Light wear marks on shaft circumference will not normally impede the operation of the pump. **Replace both gears** if either gear shafts are scored or damaged.

Note: ALWAYS replace all bushings if either gear shaft is worn or damaged.

4.4 Bearing plate (2) (Section 4.4.1 applies when wear plates not used)

4.4.1 Visually check the bearing plate (2) surface that contacts the gears for scoring. Refer to section 6.4.

4.4.2 Visually check the bearing plate lube holes for debris. See cleaning instructions, section 5.

4.4.3 Visually check o-ring (9) and replace if damaged. (Note: if the pump is fitted with Teflon o-rings, they should be replaced each time the pump seal is broken.)

4.5 Wear Plates (4) (OPTIONAL - Used a majority of the time)

4.5.1 Visually check the wear plates (4), qty 4, surface which contacts the gears for scoring. Refer to section 6.4.

4.5.2 Visually check the wear plates (4), qty 4, lube holes for debris. See cleaning instructions, section 5.

4.6 Cavity Plate (8)

4.6.1 Visually check the cavity plate (8) for scoring in the gear cavity bores. Refer to section 6.3.

4.6.2 Visually check o-ring (9) and replace if damaged. (Note: If the pump is fitted with Teflon o-rings, they should be replaced each time the pump seal is broken.)

4.7 Pump Body (10) (Section 4.7.1 applies when wear plates not used)

4.7.1 Visually check the pump body (10) surface that contacts the gears for scoring. Refer to section 6.4.

MICROPUMP, INC.

A Unit of IDEX Corporation

PO Box 8975, Vancouver, WA 98668-8975 • Phone: 360/253-2008 • Fax: 360/253-8294

MICROPUMP LIMITED

A Subsidiary of Micropump, Inc.

Howard Road, Eaton Socon, St. Neots, Cambridgeshire, PE 19 3ET England, • Phone: (44) (0) 1480-356600 • Fax: (44) (0) 1480-356300

REVISION			
LTR.	DESCRIPTION	DATE	BY
C	UPDATED DRAWING	3/28/00	DHA

4.7.2 Visually check o-ring (11) and replace if damaged. (Note: If the pump is fitted with Teflon o-rings, they should be replaced each time the pump seal is broken.)

5 Cleaning of Pump Assembly

5.1 Cleaning agents and materials

5.1.1 Use either a stoddard solvent or a mild solution of soap and water to clean the parts. Masking tape will also be required.

5.2 Cleaning Procedures

5.2.1 Clean all metal and plastic parts with the solvent or soap solution. Rinse thoroughly and allow to dry, or blow dry with clean, dry, compressed air.

CAUTION: DO NOT USE DETERGENT SOLUTION OR SOLVENT ON ELECTRICAL PARTS OR MOTOR BEARINGS.

5.2.2 Remove all metal particles from the driven magnet (12) and hub assembly by pressing adhesive side of masking tape against particles and removing tape.

Note: Loose iron particles and metal filings will be attracted to the magnet surface and must be forcibly removed to prevent introducing rust into the system.

6 Repair of Pump Assembly

Note: Repair of the pump assembly is primarily limited to replacing parts.

6.1 Replace any part which exhibits damage such as wear, cracks, breaks, and excessive scoring. See section 6.4 below regarding scoring of the wear plates (4) (or bearing plate (2) and pump body (10) if wear plates are not used).

6.2 Replace bushings (3) to correct for side “rub” marks on inside of magnet cup (13) and on side of driven magnet (12). See repair instructions, section 6.5.

6.3 Replace cavity plate (8) if gear cavity bores indicate excessive wear or damage.

MICROPUMP, INC.

A Unit of IDEX Corporation

PO Box 8975, Vancouver, WA 98668-8975 • Phone: 360/253-2008 • Fax: 360/253-8294

MICROPUMP LIMITED

A Subsidiary of Micropump, Inc.

Howard Road, Eaton Socon, St. Neots, Cambridgeshire, PE 19 3ET England, • Phone: (44) (0) 1480-356600 • Fax: (44) (0) 1480-356300

REVISION			
LTR.	DESCRIPTION	DATE	BY
C	UPDATED DRAWING	3/28/00	DHA

6.4 Scoring of wear plates (or bearing plate & pump body when wear plates not used)

6.4.1 Score marks that are deeper than 0.010” (.26 mm) cannot be corrected by the following procedure and require replacement of the parts.

Minor scoring in the area of gear contact may be corrected by lightly sanding with #600 wet/dry sandpaper. Place dry sandpaper on the surface plate, or equivalent flat surface. A table top is not flat enough ! Do not use creased sandpaper! Lightly sand in a “figure 8” pattern, taking care to keep the part flat against the sandpaper. Avoid rocking the part, or applying unequal pressure to the top of the part. Normally the deepest score marks will be found within a 1” (25.4mm) diameter around the shaft holes. Typically, scoring outside this area can be removed after 4-6 passes, and all but the deepest marks will be removed after 25-30 passes. If after 30 passes the score marks occupy more than 10% of the total area in contact with the gear, replace the part. Do not attempt to sand out deep score marks. Clean thoroughly after sanding; see cleaning instructions in section 5.2.

6.5 Bushing Installation

6.5.1 Remove all bushings (3) from bearing plate (2) and pump body (10) using a tap and handle. Thread tap into bushing approximately ½” (12 mm) and pull bushings out.

6.5.2 Install 4 bushings into bearing plate (2) 0.010” to 0.020” (0.26 mm to 0.51 mm) below bearing plate sealing surface, with the slots (if present) aligned as shown in figure 2. Use a bushing insertion tool and hand press or non-rotating drill press.

6.5.3 Install the first 4 bushings into pump body (10) 0.010” to 0.020” (0.26 mm to 0.51 mm) below sealing surface of the “gear end” of the pump body. Align the bushings slots as in figure 2. Install the remaining bushing into pump body from driven magnet (12) end, aligning the slots as in figure 2, and the bushing flush with the pump body surface.

6.5.4 Check all bushings for proper installation depth. Check bushings after installation with a new gear shaft to insure that clearance between shafts and bushings is at least a sliding fit.

MICROPUMP, INC.

A Unit of IDEX Corporation

PO Box 8975, Vancouver, WA 98668-8975 • Phone: 360/253-2008 • Fax: 360/253-8294

MICROPUMP LIMITED

A Subsidiary of Micropump, Inc.

Howard Road, Eaton Socon, St. Neots, Cambridgeshire, PE 19 3ET England, • Phone: (44) (0) 1480-356600 • Fax: (44) (0) 1480-356300

REVISION			
LTR.	DESCRIPTION	DATE	BY
C	UPDATED DRAWING	3/28/00	DHA

6.5.5 If bushings are tight on shafts, very carefully hand ream bushings after installation using a 0.251" (6.4 mm) diameter reamer. This should be done as straight as possible to obtain maximum perpendicularity. **Do not force reamer into bushings, and do not ream bushings unless necessary.**

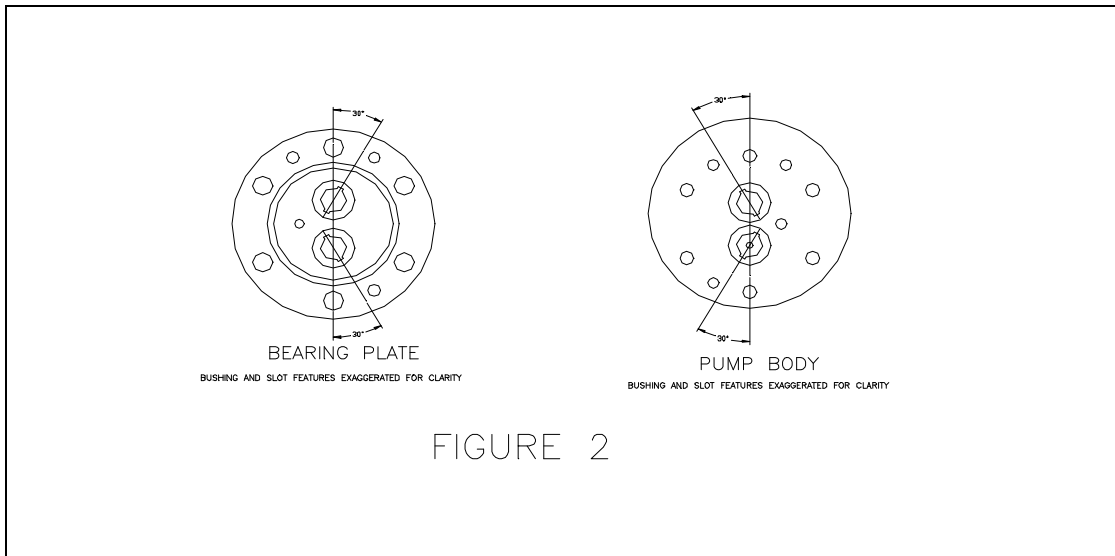

7 Pump assembly (Refer to Figure 1)

Caution: Do all work on a clean surface free of metal particles.

- 7.1 Install driving gear (6) into pump body (10) center hole with the long end of the gear shaft placed in the hole. The shaft should slide and rotate freely in the bushings (if not: see repair instructions, section 6.5.5.).

MICROPUMP, INC.

A Unit of IDEX Corporation

PO Box 8975, Vancouver, WA 98668-8975 • Phone: 360/253-2008 • Fax: 360/253-8294

MICROPUMP LIMITED

A Subsidiary of Micropump, Inc.

Howard Road, Eaton Socon, St. Neots, Cambridgeshire, PE 19 3ET England, • Phone: (44) (0) 1480-356600 • Fax: (44) (0) 1480-356300

REVISION			
LTR.	DESCRIPTION	DATE	BY
C	UPDATED DRAWING	3/28/00	DHA

- 7.2 Install driven gear (7) into the remaining pump body (10) hole containing bushings, with the long end of the gear shaft placed in the hole. The shaft should slide and rotate freely in the bushings (if not: see repair instructions, section 6.5.5). Check that gears rotate easily and mesh without sticking. Place the two wear plates (if used) over the gears, orienting the flow holes as shown in the drawing.
- 7.3 Install 2 dowel pins (5) into pump body (10).
- 7.4 If elastomer o-rings are used, apply a light even film of Dow Corning vacuum grease or equivalent (**do not use on Teflon seals**). Apply grease from capsule to the thumb and index finger of one hand, and transfer a light even film to the surface by rubbing o-ring between thumb and index finger. Check that **entire** surface of o-ring is coated with vacuum grease.
- 7.5 Install the 2 o-rings (9); one into the cavity plate (8) o-ring groove and the other into the bearing plate (2) o-ring groove. Teflon o-rings may require slight stretching in order to fit into the grooves.
- 7.6 Place the cavity plate (8) over the gears/wear plates (if used) and onto the pump body (10) dowel pins. Press the cavity plate flush with the pump body sealing surface.
- 7.7 Install 2 dowel pins (5) into cavity plate (8).
- 7.8 Place the bearing plate (2) over the gears/wear plates (if used) and onto the cavity plate (8) dowel pins. Press the bearing plate flush with the cavity plate sealing surface.
- 7.9 Install 6 screws (1) through the bearing plate (2) and into the pump body (10). Torque to 40 in-lbs. It is advised to apply a light oil to screw threads and under screw head before installation.

Note: Pumps with Teflon o-rings may require screws to be tightened 2 to 3 times, due to the hardness of the Teflon material.

MICROPUMP, INC.

A Unit of IDEX Corporation

PO Box 8975, Vancouver, WA 98668-8975 • Phone: 360/253-2008 • Fax: 360/253-8294

MICROPUMP LIMITED

A Subsidiary of Micropump, Inc.

Howard Road, Eaton Socon, St. Neots, Cambridgeshire, PE 19 3ET England, • Phone: (44) (0) 1480-356600 • Fax: (44) (0) 1480-356300

REVISION			
LTR.	DESCRIPTION	DATE	BY
C	UPDATED DRAWING	3/28/00	DHA

- 7.10 If an elastomer o-ring is used, apply a light even film of Dow Corning vacuum grease or equivalent (**do not use on Teflon seals**). Apply grease from capsule to the thumb and index finger of one hand, and transfer a light even film to the surface by rubbing o-ring between thumb and index finger. Check that **entire** surface of o-ring is coated with vacuum grease.
- 7.11 Install one o-ring (11) into the pump body (10) o-ring groove. Teflon o-rings may require slight stretching in order to fit into grooves.
- 7.12 Position driven magnet (12) on driving gear (6) shaft, aligning magnet set screw with flat of shaft. Locate driven magnet at a set height of .375" (9.5 mm) as shown in Figure 1, and tighten set screw on flat of shaft.
- 7.13 Check that driven magnet (12) is free of metal particles (see cleaning instructions, section 5). Check that driving gear (6) shaft rotates without sticking (see repair instructions, section 6.5.5).
- 7.14 Install magnet cup (13) over driven magnet (12), onto o-ring (11) in pump body.
- 7.15 Complete the pump assembly with 16 screws (15) (8 screws for low pressure version) installed through the drive housing (14) and into the pump body (10). Torque to 14 - 15 in-lbs It is advised to apply a light oil to screw threads and under screw head before installation.
- 7.16 Check that all screws are seated. There should not be any gaps between mating parts.

8 Pump to Motor Assembly

- 8.1 The hub assembly should be attached to the motor shaft using key and set screw. The hub assembly is designed so that when placed on the motor shaft it will automatically bottom out at the proper setting
- 8.2 Install pump assembly onto motor. **Care should be taken to disallow the hub assembly from impacting the magnet cup due to high magnetic**

MICROPUMP, INC.

A Unit of IDEX Corporation

PO Box 8975, Vancouver, WA 98668-8975 • Phone: 360/253-2008 • Fax: 360/253-8294

MICROPUMP LIMITED

A Subsidiary of Micropump, Inc.

Howard Road, Eaton Socon, St. Neots, Cambridgeshire, PE 19 3ET England, • Phone: (44) (0) 1480-356600 • Fax: (44) (0) 1480-356300

PART NUMBER:	L4818
--------------	-------

REVISION			
LTR.	DESCRIPTION	DATE	BY
C	UPDATED DRAWING	3/28/00	DHA

attraction.

- 8.3 Determine proper port location, and position pump assembly accordingly.
- 8.4 Install 4 bolts and torque to 20 in-lbs.
- 8.5 Test pump to applicable specifications for the pump/motor combination.

9 Storage

- 9.1 Prepare the pump for storage by installing plugs into the inlet and outlet ports.
Note: Tape can be used in lieu of plugs for sealing ports.
Remove as much fluid as possible from the pump prior to sealing ports.
- 9.2 Store the pump in any position in an ambient temperature-humidity environment.
Note: If water is left in the pump, damage may occur if the temperature drops below freezing.

Instruction Sheet to include Spare Parts List for each 5500 Pump.

MICROPUMP, INC.

A Unit of IDEX Corporation

PO Box 8975, Vancouver, WA 98668-8975 • Phone: 360/253-2008 • Fax: 360/253-8294

MICROPUMP LIMITED

A Subsidiary of Micropump, Inc.

Howard Road, Eaton Socon, St. Neots, Cambridgeshire, PE 19 3ET England, • Phone: (44) (0) 1480-356600 • Fax: (44) (0) 1480-356300

