



Spring-Loaded Y Check Valves



1/2" to 4" - PVC



Features

- Full Flow Design
- Easy Maintenance
- Closes with No Back Pressure
- Adjustable – Opens from 2 to 15 psi
- Works in Any Position
- FPM or EPDM Seals

Backflow Prevention

Hayward's Spring Loaded Y Check valves give positive protection against reversal of flow in a piping system – even in the absence of back pressure. Check valves that are not spring loaded require fluid back pressure to seal. If an application cannot produce enough back pressure, the standard check valve can't seal. Hayward's Spring Loaded Check Valves do not require system generated back pressure to work.

Applications

Installed downstream of a pump, these valves prevent unwanted flow of the process fluid once the pump has been turned off – even if there is no back pressure. For process vessels located inside a secondary containment area, this prevents siphoning of the vessel. For open distribution lines, Hayward's Spring Loaded Check Valves optimize operational efficiencies by preventing unwanted loss of process fluid. And by retaining the process fluid downstream of the pump, Hayward Spring Loaded Check Valves greatly reduce the likelihood of water hammer that can occur if a pump is started in an empty, open line.

Reliable, Flexible Operation

Hayward Spring Loaded Check Valves are hand adjustable and can be set to open the valve at pressures from 2 to 15 psi...a real advantage over other types of spring loaded check valves that require a separate spring for each setting. A lock ring reliably holds the adjustment after it has been set. The double seal design of the valve ensures seal integrity and long life.

Easy Maintenance

There is no need to remove Hayward's Spring Loaded Check Valve from the piping system for service. Just remove the heavy-duty hex cap for quick access to the internal valve components.

No Corrosion Failures

Because of their all-plastic construction, these valves will never jam or stick due to rust or corrosion. Also they will not contaminate sensitive fluids that come into contact with them. And, they require no painting or coating to withstand corrosive environments.

Technical Information

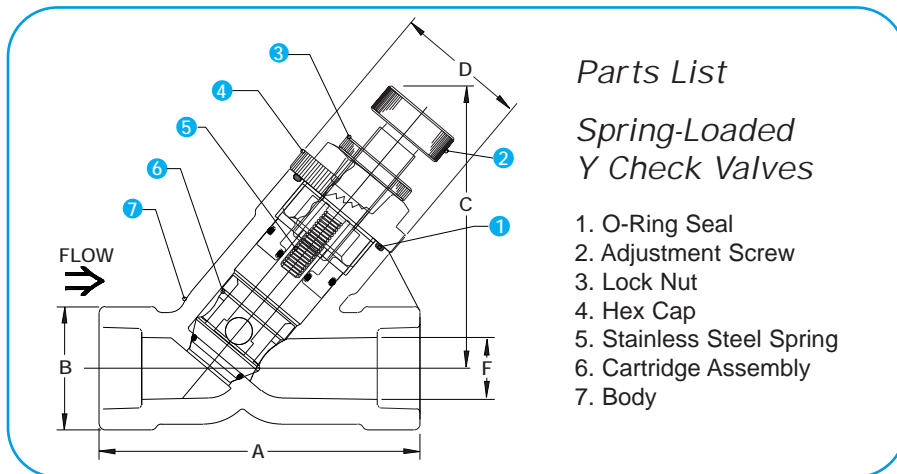

Parts List

Spring-Loaded Y Check Valves

1. O-Ring Seal
2. Adjustment Screw
3. Lock Nut
4. Hex Cap
5. Stainless Steel Spring
6. Cartridge Assembly
7. Body

Dimensions – Inches / Millimeters

Size	A	B	C	D	F	Weight (lb / kg) Socket/Threaded
1/2"	6.19 / 158	2.00 / 51	4.58 / 116	2.13 / 54	1.00 / 25	0.88 / 0.40
3/4"	6.19 / 158	2.00 / 51	4.58 / 116	2.13 / 54	1.00 / 25	0.88 / 0.40
1"	5.19 / 132	2.00 / 51	4.58 / 116	2.13 / 54	1.00 / 25	0.88 / 0.40
1-1/2"	8.63 / 220	3.38 / 86	7.28 / 185	3.75 / 95	2.00 / 51	3.00 / 1.36
2"	7.63 / 194	3.38 / 86	7.28 / 185	3.75 / 95	2.00 / 51	3.00 / 1.36
3"	10.31 / 262	4.69 / 119	8.88 / 225	5.25 / 133	2.94 / 75	7.50 / 3.41
4"	12.75 / 324	5.75 / 146	10.08 / 256	6.00 / 152	3.81 / 97	9.50 / 4.32

Selection Chart

Size	Material	End. Conn	Seals	Rating
1/2" - 4"	PVC	Threaded	FPM or EPDM	150 PSI @ 70F

Pressure Loss Calculation Formula

$$\Delta P = \left[\frac{Q}{Cv} \right]^2$$

ΔP = Pressure Drop
 Q = Flow in GPM
 Cv = Flow Coefficient

Operating Temperature/Pressure

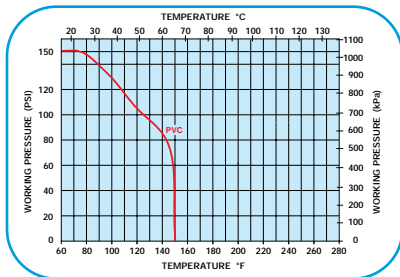

Cv Factors

Size	Factor	Size	Factor
1/2"	0.8	2"	65
3/4"	3.0	3"	110
1"	9.0	4"	240
1-1/2"	45		

Typical Applications

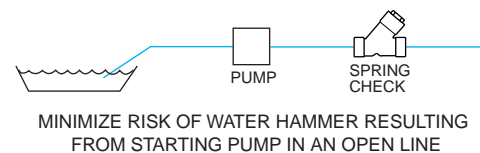
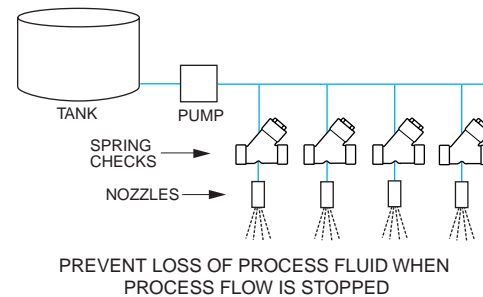
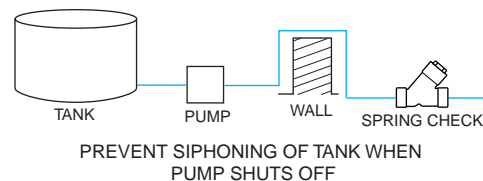

Hayward Industrial Products, Inc.

One Hayward Industrial Drive, Clemmons, NC 27012
 Tel: 1-888-429-4635 (1-888-HAYINDL) • Fax: 1-888-778-8410
 E-mail: hflow@haywardnet.com
 Web Site: <http://www.haywardindustrial.com>