



---

### **GENERAL INFORMATION**

---

The FT415 is a microcontroller-based rate/total indicator powered by a lithium battery. It displays rate and total, and provides a programmable pulse output for use in metering pump pacing or datalogging.

The rugged cast-aluminum housing is gasketed for maximum environmental protection, and the electronics are potted into a solid block of urethane. A membrane keypad allows settings to be changed without removing the cover. The universal mount version comes with brackets for wall mounting, and also with an adaptor for field installation on TX80-series flow sensors. The FT415 can also be factory or field installed on a TX100/200 series sensor or WT meter. (Passive pickups are required to prolong battery life.)

The standard output is a programmable 0.1 second open-collector transistor (TTL) pulse which can be used to trigger most externally-paced metering pumps.

**TYPICAL APPLICATION**

---

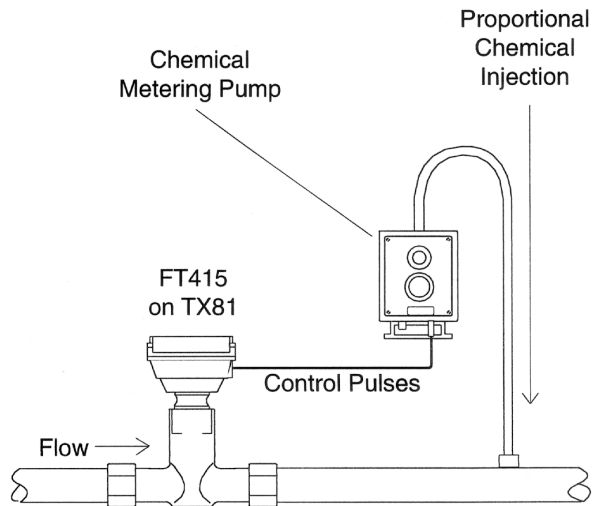
**Typical Application**

4-6

**SPECIFICATIONS**

---

<b>Display</b>	
<b>Rate</b>	6-digit autorange, 112" character height
<b>Total</b>	8-digit, 5/16" character height
<b>Pulse Output</b>	0.1 second open collector pulse
<b>Input</b>	sine-wave
<b>Input Range</b>	Minimum: 20 mV peak-peak Maximum: 6V peak-peak
<b>K factor Range</b>	0.050-2000
<b>Pulse Output Range</b>	0.1 - 200,000 units/pulse
<b>Battery Type</b>	Lithium "C", 3V, replaceable
<b>Normal Battery Life</b>	3-5 years
<b>Temperature</b>	0 C - 70 C
<b>Environmental</b>	NEMA 4X

---

**INSTALLATION**

---

To mount the FT415U on a wall, hold the unit in the desired position, mark the holes in the mounting feet, drill, and mount with screws.

This unit can also be mounted directly on a flow sensor for local reading. Note that the FT415 requires the optional passive sensor in order to conserve battery life. For loop or other external power, the FT420 is recommended, and can be installed on any standard sensor. If the unit was ordered as an FT415M, factory mounted to the top of a 100 or 200 Series flow sensor, no further installation is required.

To mount the unit on a flow sensor, first remove the wall mount feet. Then remove the housing cover. Place the lower half of the housing in the groove on the top of the flow sensor. An adaptor is included in the packaging of the FT415 which threads into the top of any 80 Series flow sensor. Pull the sensor wires through the hole in the center of this adaptor, then thread the adaptor into place. Tighten the adapter using a screwdriver. (See diagram). Connect the wires, then replace the housing cover, orienting it any direction as desired for viewing convenience.

4-7

---

**CONNECTION**

---

To connect the FT415 to a flow sensor, follow the diagram marked "Connections". This diagram also shows the connections for an external device, such as a chemical metering pump.

For wall mount installations, note that the flow sensor shield wire must be connected to the green-tinted grounding screw, provided in the bottom half of the housing. This protects the low-voltage output of the passive sensor from electromagnetic interference.

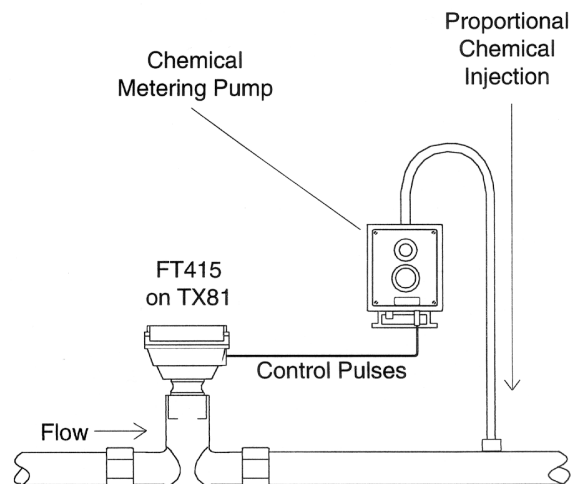

**Sensor Mount: Step 1**

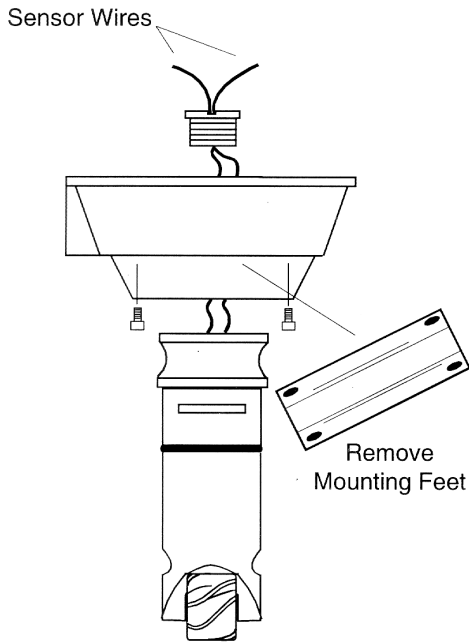

**Sensor Mount: Step 2**

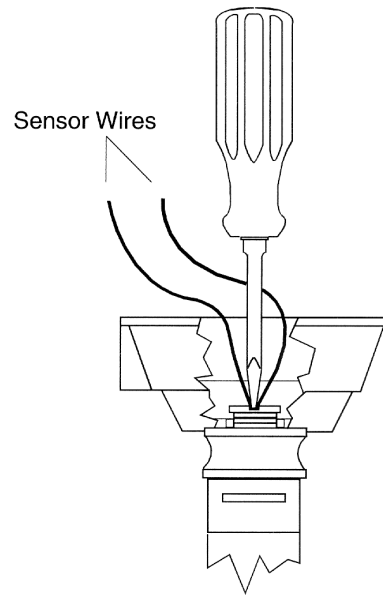

4-8

**Standard Connections**

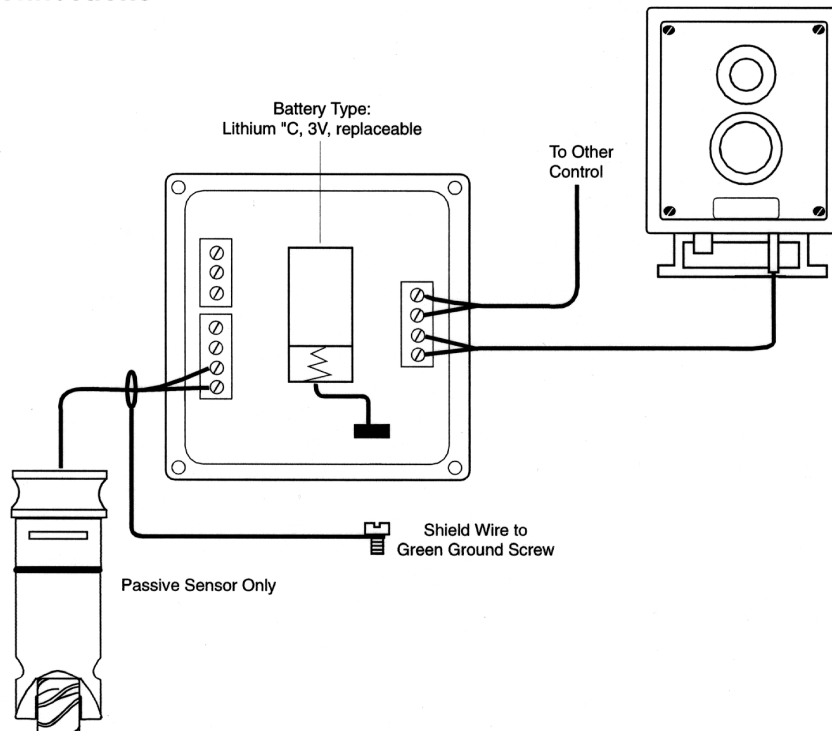

## Dimensions

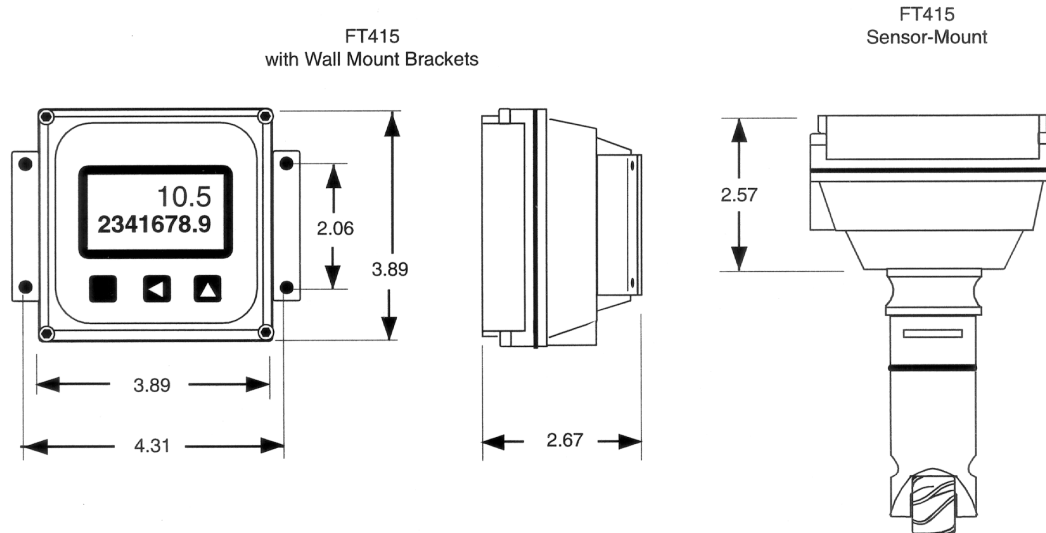

## OPERATION

To return to normal operation after entering settings, press SET for a fourth time. The rate and total indicator numbers should appear in the display. If the unit is connected to an operating flow sensor, the larger-sized digits indicate flow rate and the smaller-sized digits indicate total.

Unless the unit has been ordered with the non-reset option, a RESET prompt is constantly visible in the lower right corner, above the up arrow key. Press this key at any time to reset the totalizer to zero.

The expected average life of the battery is approximately four years with a range of 3-5 depending on

the frequency of the input. Pull the battery from its holder and replace it with the new one. Note that when the battery is removed, all of the settings previously entered will be retained. However, the totalizer will reset to a previous total, which represents the last autobackup (approximately one hour intervals.) If it is necessary to save the exact current total at the time of the battery change, save before removing the battery, by simultaneously pressing the SET and up arrow keys. Then press SET again, then again simultaneously press the SET and up arrow keys.

## PROGRAMMING

---



**CAUTION:** If pulse output is being used to control an external device, such as a metering pump, do not connect the pulsed device until programming is completed. If malfunction or incorrect programming of the pulse output could cause personal injury or property damage, separate safeguards must be installed to prevent such injury or damage.

At a minimum, every FT415 must be programmed with the “K-factor”. This is simply the number of pulses per gallon which the meter or flow sensor produces. (If you wish the FT415 to read in another unit, enter the number of pulses per that unit. For example, if the desired units are liters, the K-factor is the number of pulses per liter that the flow sensor produces.)

To find the K-factor on any Hays Fluid Controls flow sensor fitting or in-line meter, look on the model-serial label. The line reading K = xxxx is the desired number. For adjustable sensors (101,201,115,215) look in the instruction manual under your pipe size.

**4-10** Set K. Begin by pressing the key SET once. The prompt SET K should appear on the display. The digit to the far right will be blinking. Use the up arrow key to reach your desired digit. Then press the left arrow key to move to the next digit. Repeat the process until the entire number is entered. (Note that the decimal is fixed at three places. If you only have two decimal places for your K-factor enter a zero for the third digit.)

Set P. If the pulse output is to be used, set the desired pulse rate. This is the number of gallons (or other units, if you are using them) between pulses. The second time the SET key is pressed, SET P will appear. Follow the same process as above to enter the desired number.

**Set Decimal Point.** The third time the SET key is pressed, a D prompt appears. Pressing the up arrow key switches back and forth between no decimal place and one decimal place