



OPERATING INSTRUCTION MANUAL

MS SERIES CONDUCTIVITY CELLS

REV. 3.0

AquaMetrix Inc.
1245 Maple Hill Court, Unit 7
Newmarket, ON
Canada, L3Y 9E8

Tel: (800) 742-1413
(905) 954-0841
Fax: (905) 954-0415
www.aquametrix.com

TABLE OF CONTENTS

<u>1.0</u>	<u>GENERAL INFORMATION</u>	1
<u>1.1</u>	<u>Introduction</u>	1
<u>1.2</u>	<u>Cautions To Be Observed</u>	1
<u>2.0</u>	<u>SPECIFICATIONS</u>	2
<u>3.0</u>	<u>PRINCIPLE OF OPERATION</u>	3
<u>4.0</u>	<u>INSTALLATION</u>	4
<u>4.1</u>	<u>Installation of Flow-Through Sensors</u>	4
<u>4.2</u>	<u>Installation of Submersion Sensor</u>	4
<u>6.0</u>	<u>TROUBLESHOOTING AND SERVICE</u>	6
<u>7.0</u>	<u>DRAWINGS</u>	7
<u>7.1</u>	<u>N106-114 MS SERIES CONTACTING CONDUCTIVITY CELLS</u>	7
<u>7.2</u>	<u>N105-60 INSTALLATION OF MS SERIES CONTACTING CONDUCTIVITY CELLS</u>	8
<u>7.3</u>	<u>N105-61 ASSEMBLY OF MS SERIES CONTACTING CONDUCTIVITY CELLS COMPRESSION FITTING</u>	9

MS SERIES CONDUCTIVITY CELLS INSTRUCTION MANUAL

1.0 GENERAL INFORMATION

1.1 Introduction

- 1.1.1 This manual provides information on AquaMetrix Model MS Series flow-through and submersion sensors. Conductivity sensors have long been called cells. The two terms, cell and sensor, are used interchangeably in this manual.

1.2 Cautions To Be Observed

- 1.2.1 Consult the factory before using sensor in extremely strong solvents such as ethylene dichloride. Also, do not exceed the sensor's maximum ratings listed in Section 2 of this manual.
- 1.2.2 Before placing sensor into service, remove protective plastic cap.
- 1.2.3 Do not exceed the maximum sensor-to-analyzer distance specified for the analyzer you are using.
- 1.2.4 Be sure the cell constant is appropriate for the scaling of the analyzer. The constant is given in the numerical part of the model number. For example, MS001P has a constant of 0.01; MS1P has a constant of 1.

2.0 SPECIFICATIONS

CELL CONSTANTS: 0.01 to 50

THREADED SIZE: 3/4" NPT

TEMPERATURE COMPENSATION: Automatic 0-120°C (32-248°F)

CABLE LENGTH: 4m (13ft)

INSERTION LENGTH: Variable (see Section 4.1.5)

WETTED MATERIALS:

MS_P: Graphite, Epoxy, EPDM, CPVC

MS_S: Graphite, Epoxy, Polypropylene, 316 stainless steel

SAFETY FEATURE: Shoulder on cells provides an integral safety stop

TEMPERATURE and PRESSURE:

<u>Type</u>	<u>Max. Press. (psi)</u>	<u>Max. Temp. (°C)</u>
P	50	60
	100	50
	150	20
S	250	120

3.0 PRINCIPLE OF OPERATION

- 3.1** All solutions containing water conduct electricity to some extent. The ability of the solution to conduct electricity is called “conductance” (the reciprocal of resistance). Addition of electrolytes such as salts, acids, or bases to pure water will increase the ability of the liquid to conduct electricity and hence, increase the solution’s conductance (decreases the resistance).
- 3.2** An electrolytic conductivity system measures solution conductance by using an analyzer interconnected with cable to a sensor immersed in the solution. The conductivity sensor is composed of two or more electrodes and a temperature sensor. The electrodes are in contact with the solution. The analyzer circuitry impresses an alternating voltage between the electrodes and the magnitude of the resulting current is linearly related to the solution conductivity.
- 3.3** When the temperature of a solution changes, its conductivity changes. The temperature change is compensated with a thermistor (temperature sensitive resistor) in the conductivity sensor to alter the gain of the measuring circuit. This is accomplished such that, regardless of actual solution temperature, the instrument display indicates what the solution conductivity would be if the solution temperature was 25°C (an internationally accepted reference).

4.0 INSTALLATION

4.1 Installation of Flow-Through Sensors Refer to Dwg# N105-60

- 4.1.1 Flow-through sensors are secured with the supplied compression fitting. The insertion length is adjustable within the limits shown in DWG# N106-114. If your sensor has a cross hole it must be inserted far enough to be sure the cross hole is in the solution. Use thread sealant such as Teflon tape on the sensor and the mounting hardware threads.
- 4.1.2 Install a 3/4" NPT tee into the process line. Tee material should be compatible with sensor materials of construction for best chemical resistance and pressure/temperature ratings. A 1" NPT tee with a 1x3/4" reducer may also be used.
- 4.1.3 Electrically connect sensor to the instrument as described in Section 4.3.
- 4.1.4 Remove the protective cap from the sensor and calibrate the system as described in the instrument operating instruction manual before installing sensor into the mounting tee.
- 4.1.5 Screw sensor and fitting into the tee. Locate end of the sensor or cross hole in sensor at the approximate center of the stream.

If you disassembled the cell be sure to re-assemble the components as shown in DWG# N105-61

4.2 Installation of Submersion Sensor Refer to Dwg# N105-60

- 4.2.1 Submersion sensors are designed for use in tanks, suspended from the top of the tank. Mounting hardware, model MHMSC is available from AquaMetrix. It consists of 3/4" CPVC pipe, 24" long with a cable clamp and a wire-mounting bracket.
- 4.2.2 Run the sensor cable through the desired length of 3/4" CPVC pipe and screw on the cell using a thread sealant to keep the cable end of the sensor dry.
- 4.2.3 Electrically connect the sensor to the instrument as described in Section 4.3.
- 4.2.4 Remove the protective cap from the sensor and calibrate the system as described in the instrument's operating instruction manual before installing sensor in the tank.
- 4.2.5 Place the cell in the liquid and secure to the tank in an appropriate manner using the wire bracket provided with MHMSC hardware.

4.3 Electrical Connection

The sensor is electrically connected directly to the instrument or indirectly with a junction box and interconnect cable. A suitable junction box with a terminal strip is available from AquaMetrix (Model JB-1).

4.3.1 Direct Hook-Up

- A. Route sensor cable to instrument.
- B. Connect sensor cable lead wires in accordance with instrument hook-up diagram.

Note: If you are using this conductivity cell with an AquaMetrix 2200C or 2100C instrument, connect the four wires to the cell terminals, matching the colours.

If you are using it with an instrument, which accepts 3 wires, connect as follows:

- Join the black wire and green wire together and connect to the black terminal.
- Connect the red and the white as usual to their respective terminals. CAUTION: If connecting to a GLI instrument, reverse the red and white wires.
- The shield is not required so there will be no connection to the SHEILD terminal.

4.3.2 Indirect Hook-Up with Junction Box

- A. Mount junction box with terminal strip (AquaMetrix Model JB-1) on flat surface such that its cover is removable when installed.
- B. Route sensor cable to junction box. Keep terminal strip dry to prevent problems caused by wet and/or corroded terminals.
- C. Route interconnect cable to junction box and instrument. It is recommended that this cable be run in 1/2" metal conduit for protection against moisture and mechanical damage.

Do not run line power in the same conduit with interconnect cable because "electrical noise" may interfere with the sensor signal.

- D. Connect sensor and interconnect cable lead wires by matching colours to the junction box terminal strip. Fasten cover onto junction box.
- E. Connect interconnect cable lead wires to instrument in accordance with instrument hook-up diagram.

4.3.2 Wire Designations

White / Black: Electrodes

Red / Green: Thermistor (Temperature compensation)

5.0 CLEANING THE SENSOR

- 5.1** Wipe the electrodes end with a soft cloth and rinse with clean water.
- 5.2** Clean the sensor electrodes in a soap solution using a soft cloth, brush, Q-tip or pipe cleaner. If soap solution cleaning is unsuccessful, place the sensor electrode in 10% HCl (hydrochloric acid) for 1 to 5 minutes to remove the contaminants that are acid soluble. Acid clean only if absolutely necessary. Never use abrasive cleaners on the sensor or its electrodes.

6.0 TROUBLESHOOTING AND SERVICE

- 6.1** Use the troubleshooting section in the analyzer instruction manual to determine whether the sensor or analyzer is defective.
- 6.2** Should service, parts, assistance in troubleshooting or repairs be required, please contact your AquaMetrix representative or the factory directly:

AquaMetrix Inc.
1245 Maple Hill Court, Unit 7
Newmarket, Ontario
L3Y 9E8 Canada

Tel: (800) 742-1413
(905) 954-0841
Fax: (905) 954-0415
Email: support@aquamatrix.com

An RMA# is required for all returning items. Please contact AquaMetrix if you wish to send a product for repair or evaluation. A description of the malfunction as well as the proper return address should accompany all sensors returning for repair.

REVISIONS			
SYM	DESCRIPTION	DATE	APPROVAL
1	ORIGINAL ISSUE	31JUL03	PMCLEAN

<u>CELL CONSTANT</u>	<u>DIM. A MINIMUM</u>
0.01	2-1/4"
0.05	3/4"
0.1	1/2"
0.5	1/2"
1.0	1/2"
2.0	1/2"
5.0	1"
10.0	1-1/4"
20.0	2"
50.0	2-1/2"

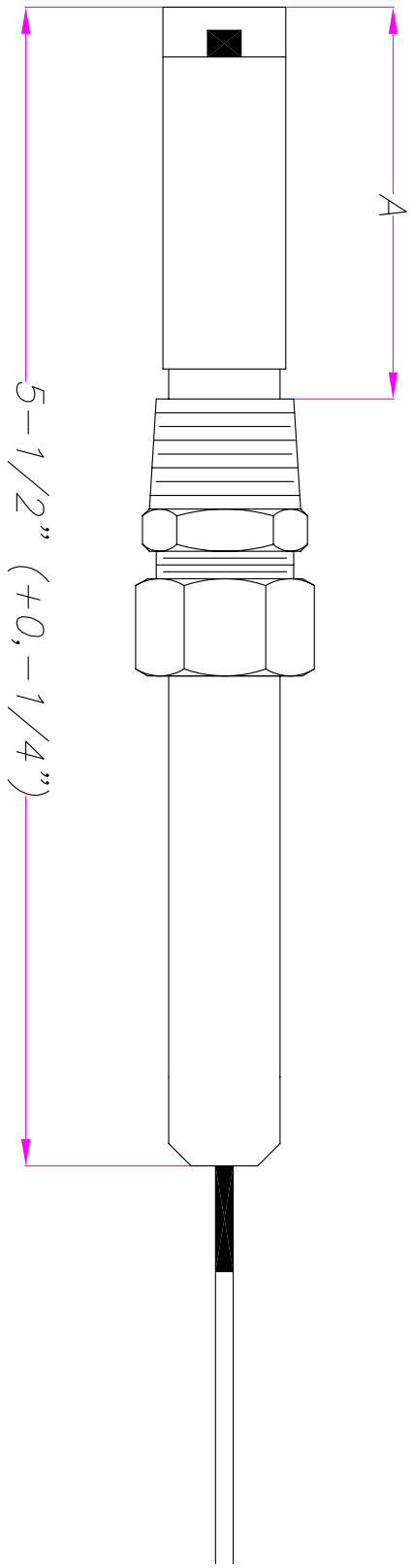

HT (HOT TAP) CELLS APPROX, 14" LONG

THE INFORMATION ON THIS DRAWING IS PRIVATE AND CONFIDENTIAL AND IS THE PROPERTY OF AQUAMETRIX INC. IT IS NOT TO BE PUBLISHED DIRECTLY OR INDIRECTLY WITHOUT THE WRITTEN PERMISSION OF THE COMPANY. ANY REPRODUCTION OR USE IN ANY MANNER WITHOUT THE WRITTEN PERMISSION OF AQUAMETRIX INC.

BY	DATE
PMCLEAN	31JUL03
CHD	31JUL03
ENGR	
APPD	PMCLEAN
	31JUL03

AquaMetrix Inc.
Industrial and Environmental Controls

MS SERIES CONTACTING
CONDUCTIVITY CELLS

CODE IDENT NO.	SIZE	AQUAMETRIX DRAWING NO.	REV.
A	A	N106-114	1

SCALE: NTS

SHEET 01 OF 01

REVISIONS			
SYM	DESCRIPTION	DATE	APPROVAL
1	ORIGINAL ISSUE	31JUL03	PMCLEAN

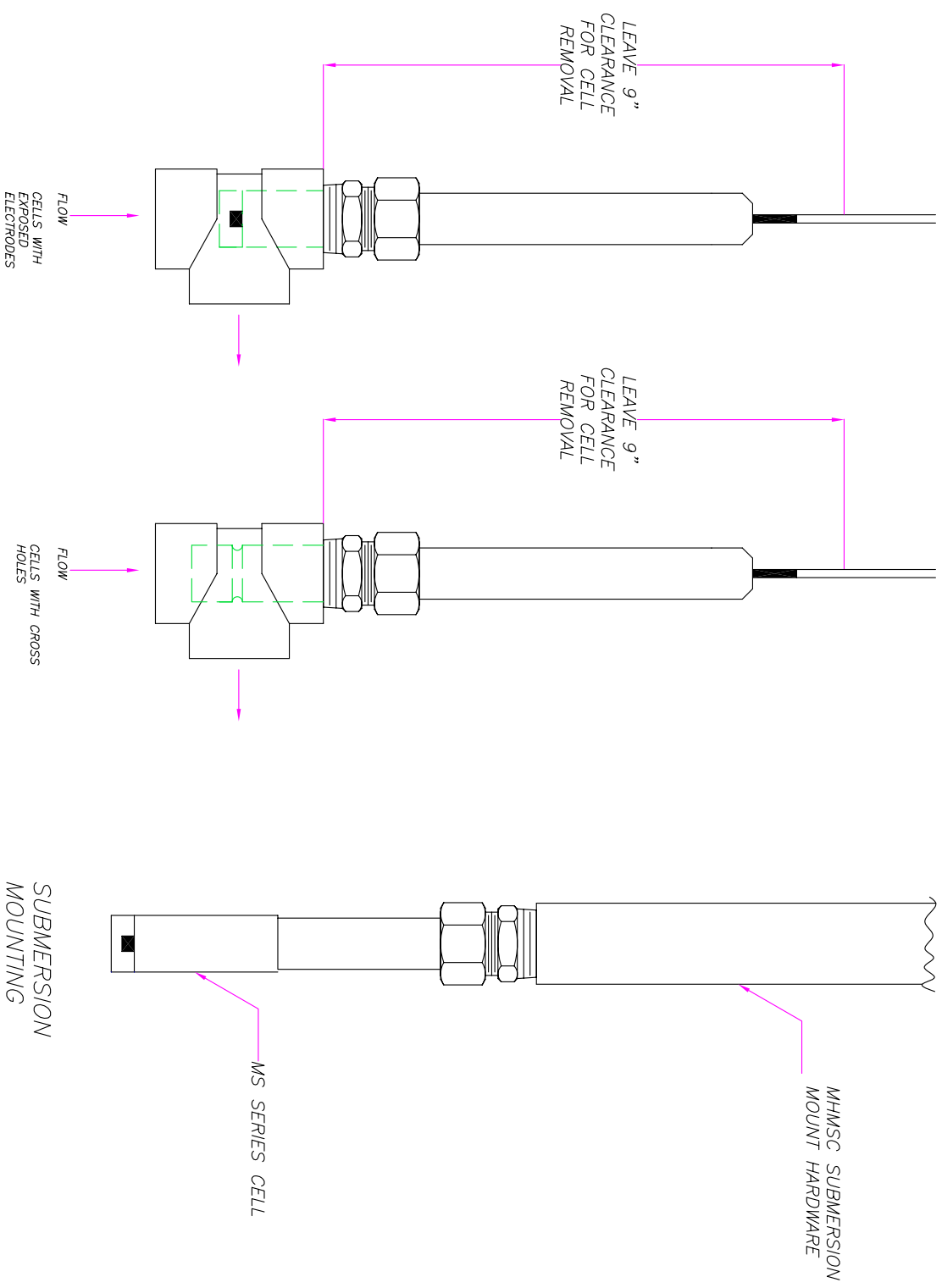

IN-LINE MOUNTING

SUBMERSION MOUNTING

THE INFORMATION ON THIS DRAWING IS PRIVATE AND CONFIDENTIAL AND IS THE PROPERTY OF AQUAMETRIX INC. IT IS NOT TO BE PUBLISHED DIRECTLY OR INDIRECTLY WITHOUT THE WRITTEN PERMISSION OF THE COMPANY. ANY REPRODUCTION OR USE IN ANY MANNER WITHOUT THE WRITTEN PERMISSION OF AQUAMETRIX INC.

BY	DATE
PMCLEAN	31JUL03
CHD	31JUL03
ENGR	

APPD	DATE
PMCLEAN	31JUL03

AquaMetrix Inc.
Industrial and Environmental Controls

INSTALLATION OF MS SERIES CONTACTING CONDUCTIVITY CELLS

CODE IDENT NO.	SIZE	AQUAMETRIX DRAWING NO.	REV.
	A	N105-60	1

SCALE: NTS

SHEET 01 OF 01

REVISIONS			
SYM	DESCRIPTION	DATE	APPROVAL
1	ORIGINAL ISSUE	31JUL03	PMCLEAN

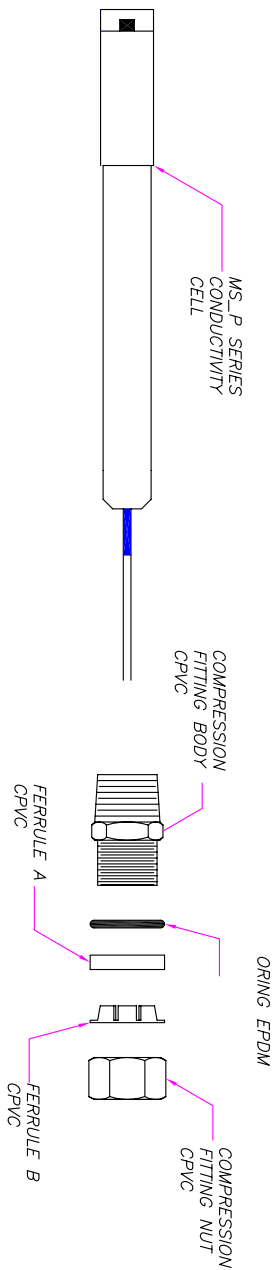

MS_P LOW TEMPERATURE CONTACTING
CONDUCTIVITY CELLS WITH CPVC
COMPRESSION FITTING FOR IN-LINE
MOUNTING

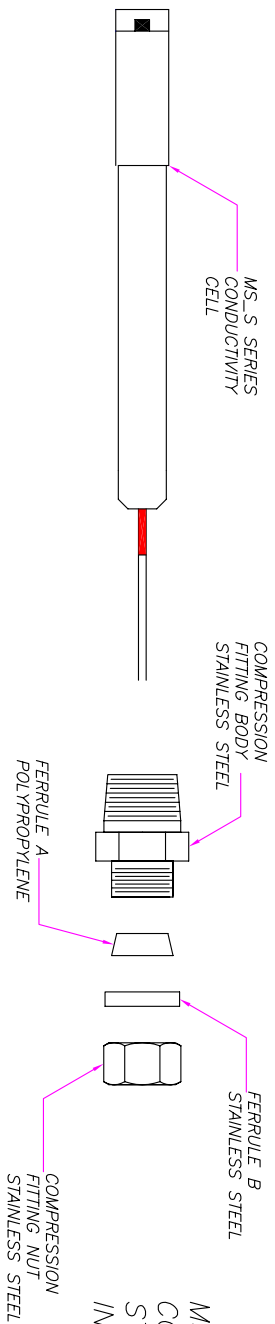

MS_S HIGH TEMPERATURE CONTACTING
CONDUCTIVITY CELLS WITH STAINLESS
STEEL COMPRESSION FITTING FOR
IN-LINE MOUNTING

SLEEVING CODES
BLUE—LOW TEMPERATURE EPOXY
RED—HIGH TEMPERATURE EPOXY

AquaMetrix Inc.
Industrial and Environmental Controls

ASSEMBLY OF MS SERIES
CONTACTING CONDUCTIVITY
CELLS COMPRESSION FITTING

BY		DATE		SCALE: NTS		SHEET 01 OF 01	
DRAWN	PMCLEAN	31JUL03		CODE IDENT NO.	SIZE	AQUAMETRIX DRAWING NO.	REV.
CHKD	PMCLEAN	31JUL03		A	A	N105-61	1
ENGR							
APPD	PMCLEAN	31JUL03					

THE INFORMATION ON THIS DRAWING IS
PRIVATE AND CONFIDENTIAL, AND IS THE
PROPERTY OF AQUAMETRIX INC. IT IS TO
NOT BE PUBLISHED DIRECTLY OR INDIRECTLY
WITHOUT THE WRITTEN PERMISSION OF THE
COMPANY. ANY REVISIONS TO THIS DRAWING
MUST BE APPROVED BY THE ENGINEER IN CHARGE
OF AQUAMETRIX INC.