



Model SHARK-120/240 Multi-Parameter Controller/Analyzer



Description

SUMMARY

The SHARK series is designed to be the most flexible, easy to use, and easy to see multi-parameter controller/analyzer on the market.

FOUR MEASURING PARAMETERS

Select the parameter you wish to measure from the easy-to-use LCD menu on the inside front cover. Choose Conductivity, pH, ORP or Flow.

NO EXTRA CARDS / OPTIONS REQUIRED

Each SHARK comes complete. There are no extra costs associated with buying boards for different applications, or buying components to achieve NEMA 4X.

UNIVERSAL MOUNTING

Universal mounting kit is included for surface, panel and pipe-mount applications. The 1/4 DIN enclosure makes panel-mount cutouts and engineering simple.

SNAP-ON TERMINAL CONNECTORS

Wiring is easy with removable / snap-on terminal connectors.

DISPLAYS & MENUS

There are two displays on SHARK. A bright LED numeric display with bar graph on the outside front panel, and a 2-line, 16-character LCD display on the inside. The LED readout on the outside panel can be seen several yards away. The distinctive, color-coded bar graph will immediately indicate if you are within the process parameters that you set (green), if the control relays are on (yellow) and if you are in alarm condition (red). This makes diagnosing pump and alarm malfunctions easy. All configuration and control functions are performed on the LCD menu on the inside front panel.

CALIBRATION

Calibration is performed easily from the front panel. Temperature (where applicable) is also checked from the front. Since this routine maintenance does not require opening the front panel to access the main menu on the inside, configuration settings cannot be adjusted by mistake. Process and temperature (where applicable) calibration can also be performed from the LCD menu, where calibration data (slope, temperature and efficiency) are displayed. pH can be calibrated using Manual or Auto Calibration methods. Calibration data can be recalled, indicating calibration mode, accepted buffer values, actual sensor input signals, calibration temperature and more.

ANALOG OUTPUTS

The SHARK provides two isolated, independent and scalable 4-20 mA outputs.

RELAYS WITH CYCLE TIMERS

The instrument also provides control of external devices using its two independent control relays. A third relay is pre-set to act as an alarm relay, but can be used as a process control relay. It has both high and low on setpoints with adjustable off setpoints. Factory set for bidirectional control, both control relays can be set for either a rising or falling process, with easily programmed on setpoints and off setpoints. Each control relay has a built-in independent cycle timer, with field-set on and off times. This feature enables tighter control of batch processes by eliminating chemical overshoot.

ENCLOSURE

SHARK is packaged in a rugged NEMA 4X polycarbonate enclosure making it ideally suited for heavy-duty applications such as industrial waste water neutralization, municipal water and waste water, pulp and paper, and process control.

Features

- pH, ORP, Conductivity & Flow parameters available
- Easy to read 4 digit LED display
- Unique, bright & color-coded bar graph display
- Quick and easy to calibrate
- Relay cycle on/off timers
- Two control relays
- Two 4-20mA outputs with range expandability
- High/Low alarm relay
- 1/4 DIN •NEMA 4X enclosure
- Universal mounting hardware provided for surface, panel and pipe mounting
- Compatible with AquaMetrix models P/R60 differential pH/ORP sensors, 500 series combination style pH/ORP sensors, MS/AM series conductivity cells, and IP80/IP100/SPX flow sensors

Applications

- Process Control
- Industrial and Municipal Water Treatment
- Industrial and Municipal Waste Treatment and Neutralization
- Fume Scrubbers
- Suitable for the Plating, Circuit Board Manufacturing, Food and Beverage, Chemical Processing, Pulp & Paper, Mining, Nuclear Energy and Pharmaceutical Industries

pH, ORP, Conductivity, Flow Controller/Analyzer

Technical Data

	pH	ORP	Conductivity	Flow																	
Display	Front Panel: 4 x 7 segment 1/2" LED display, 1 LED indicator On-line, 7 LED Bar Graph Inside Panel: 2 x 16 alpha-numeric LCD display																				
Power Requirements	120Vac (±10%) 50/60Hz (less than 12VA) or 240Vac (±10%) 50/60Hz (less than 12VA)																				
Measuring Range	pH: 0.01 to 14.00 Temp: 0 to 100°C or 32° to +212°F	ORP: -1999 to +1999mV (Dependent on sensor) Temp: 0 to 100°C or 32° to +212°F	<table border="1"> <tr> <td>MΩ/cm³</td> <td>0 to 19.99</td> <td>0.01</td> </tr> <tr> <td rowspan="4">uS/cm³</td> <td>0 to 2.000</td> <td>0.01</td> </tr> <tr> <td>0 to 20.00</td> <td>0.1</td> </tr> <tr> <td>0 to 200.0</td> <td>0.1</td> </tr> <tr> <td>0 to 2000</td> <td>1.0</td> </tr> <tr> <td rowspan="2">mS/cm³</td> <td>0 to 20.00</td> <td>10</td> </tr> <tr> <td>0 to 200.0</td> <td>50</td> </tr> </table>	MΩ/cm ³	0 to 19.99	0.01	uS/cm ³	0 to 2.000	0.01	0 to 20.00	0.1	0 to 200.0	0.1	0 to 2000	1.0	mS/cm ³	0 to 20.00	10	0 to 200.0	50	Flow: 0 to 9999 with selectable flow rate units Volume: 0 to 9999 with Auto Range Flow rate units: Gallons (GP), Cubic Feet (CF), Liters (LP), Cubic Meters (CM), custom by entering factor related to Gallons Time units: Seconds (S), Minutes (M), Hours (H)
MΩ/cm ³	0 to 19.99	0.01																			
uS/cm ³	0 to 2.000	0.01																			
	0 to 20.00	0.1																			
	0 to 200.0	0.1																			
	0 to 2000	1.0																			
mS/cm ³	0 to 20.00	10																			
	0 to 200.0	50																			
Temperature Compensation	Automatic or Manual 0 to 100°C (32° to +212°F)	Not required	Automatic or Manual User selectable temperature compensation slope 0.0 to 10.0%/°C. 0 to 100°C (32° to +212°F)	Not required																	
Temperature Unit	°C or °F			Not required																	
Temperature Sensor	User selectable: 300Ω NTC Thermistor, 3000Ω NTC Thermistor or Pt. 1000 RTD			Not required																	
Calibration Modes	Auto-Calibration Manual Calibration Temperature Calibration	Manual Calibration Temperature Calibration	Dry Calibration Sample Calibration Temperature Calibration	K factor Input																	
Ambient Conditions	Temperature: -20°C to +60°C or -4°F to +140°F Humidity: 0 to 90% RH (non-condensing)																				
Menu Access Front Panel	Auto-Calibration, Manual Calibration, Temperature Display	Manual-Calibration, Temperature Display	Manual Calibration Temperature Display	Not available																	
Menu Access Inside Panel	Full Access to all parameters of operations menu																				
Sensor to SHARK Distance	Differential Sensor: 3000 ft Combination Sensor: 10 ft		300 ft	2000 ft																	
Relay Outputs	Two Control Relays, 10A / NO, 5A / NC @ 240VAC or 28VDC. Mode: Process control, Adjustable parameters: process direction, (rising or falling) on-set-point, off set-point, (0 to 100% of full scale), cycle timer (on / off, 0 to 600 seconds), failsafe (on / off). One Alarm Relay, 10A / NO, 5A / NC @ 240VAC or 28VDC. Mode: High / Low Alarm, Adjustable parameters: Low on / Low off set-point (0 to 100% of full scale, low on must be less than low off), High On / High Off set-point (0 to 100% of full scale, High on must be greater than High off).																				
Analog Outputs	4 to 20mA Channel 1 Isolated Output, Range expand 0 - 100% of full scale (min segment 10% of full scale), max. load 800Ω 4 to 20mA Channel 2 Isolated Output, Range expand 0 - 100% of full scale (min segment 10% of full scale), max. load 800Ω Can be set to track temperature if sensor is equipped with a temperature sensor																				
Memory Back-up	All user settings are retained indefinitely in memory (EEPROM)																				
Mechanical	Enclosure: NEMA 4X, 1/4 DIN, polycarbonate enclosure with four 1/2" conduit holes Mounting: Universal Mounting kit for surface, pipe and panel mount, is included																				
Sensor Input	Probe: -600 to +600mV Temp. Sensor: 0 to 9999Ω	Probe: -1999 to +1999mV Temp. Sensor: 0 to 9999Ω	Cell: 0 to 9999Ω Temp. Sensor: 0 to 9999Ω	Paddle: 0 to 2000Hz																	
Invalid Entries	Invalid entries cannot be stored																				
Manual Test Mode	Process value can be simulated with arrow keys to verify correct setup of outputs																				
Manual Relay Override	Relays can be set to on / off / auto, to verify correct wiring of auxiliary devices, or to manually adjust process																				
Output Hold	All outputs are placed on hold when SHARK is in Menu mode																				
Calibration Data	Recall data from last calibration, calibration mode, 1st & 2nd accepted buffer value and probe mV output, calibration temperature, calibration slope, and probe efficiency		Recall data from last calibration, calibration buffer accepted value, and cell resistance, calibration temperature	Recall store K factor.																	
Auto Return	User selectable auto return if SHARK is left in menu mode or if relays are left in manual override mode for more than 10 min.																				
Display Damping	User can select rate at which SHARK updates display. Enables display damping of unstable process																				
Net Weight	2.2lbs (1kg)																				
Approvals	ULC (pending)																				

Model Shark-120/240 Multi-Parameter Controller/Analyzer

Dimensions and Mounting Configurations

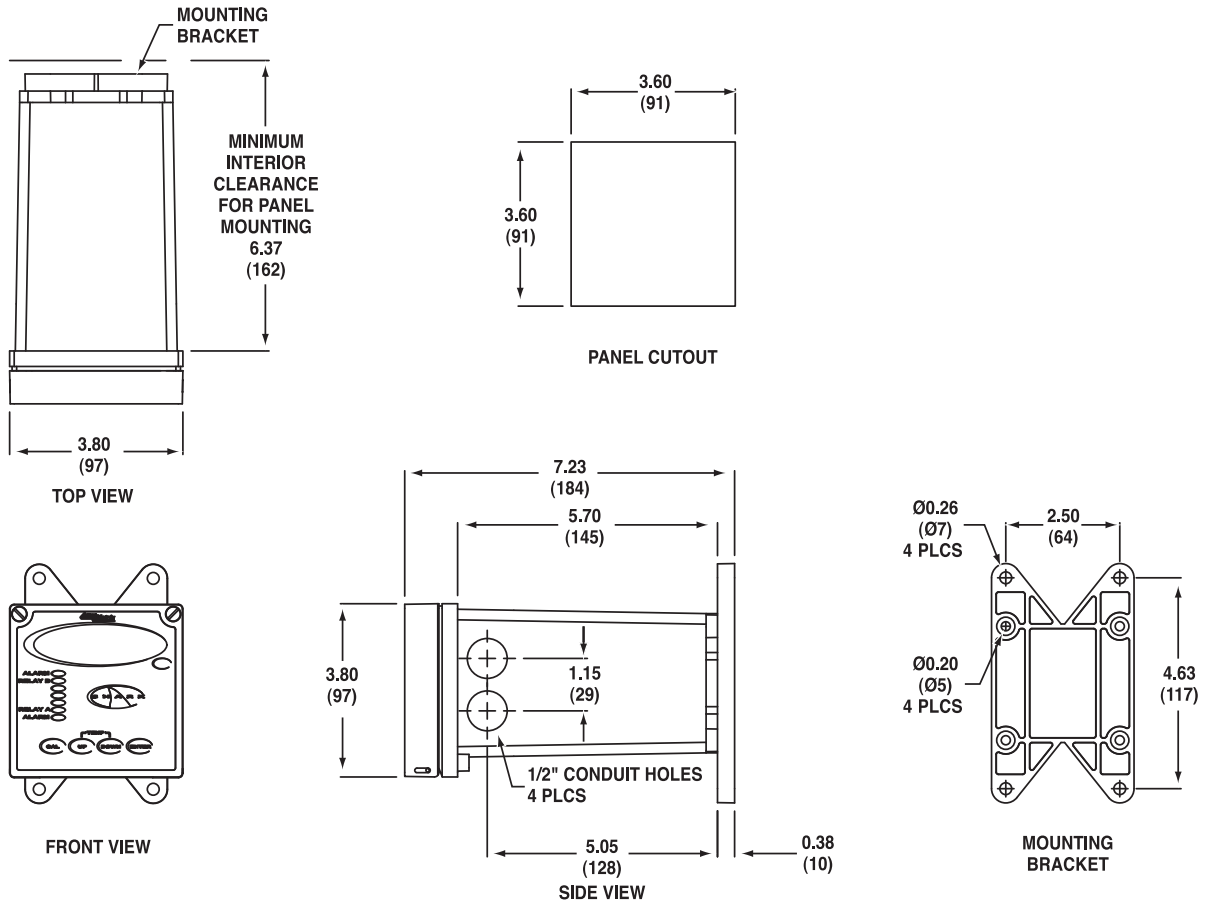

MOUNTING CONFIGURATIONS

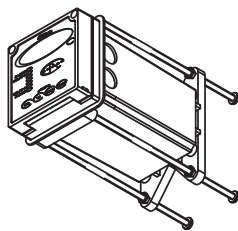

PANEL MOUNT

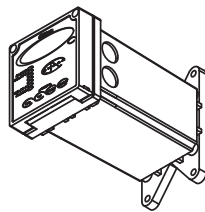

SURFACE MOUNT

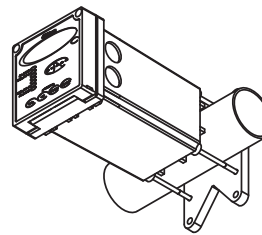

HORIZONTAL PIPE MOUNT

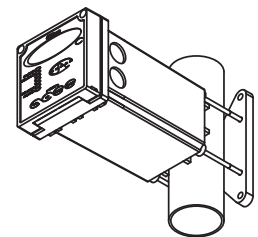

VERTICAL PIPE MOUNT

Ordering Information

SHARK Multi-parameter Controller/Analyzer
 | 120 120 Vac, 50/60 Hz Power (standard)
 | 240 240 Vac, 50/60 Hz Power
 |
 SHARK - _____



AquaMetrix Inc.
www.aquametrix.com
 1-800-742-1413

