



Features

- Low-friction, long-life jewel bearings
- Single moving part
- Six bladed impeller
- Fully field-repairable
- Choice of materials for compatibility with variety of chemicals
- Integrated Tee and sensor
- Fits 1/2" to 8" pipe sizes
- Fixed depth in fitting ensures proper placement in pipe
- High level signal can be sent up to 2000 feet
- Each fitting individually calibrated and marked with K-factor (Pulses per Gallon)

Description

The IP80 series are impeller type (or "paddlewheel") insertion meters designed for use with a wide variety of liquids in pipe sizes 1/2" to 8". Sensors are available in brass, 316 stainless steel, PVC, and polypropylene. Bodies are machined from a solid rod for maximum precision. High-quality jewel bearings and nickel-bound tungsten carbide shafts are used for extreme low friction and long life.

The rotation of the rotor is detected by a non-drag Hall-effect sensor. Output is a current-sinking pulse (square wave), which can be sent long distances (up to 2,000 feet) without a transmitter. This signal can be connected directly to PLC's, counters, and computer cards, as well as a variety of AquaMetrix controls and displays.

For rate and total display, the Shark-120/240 controller or Shark TX/P transmitter (loop powered) models are compatible with IP80 series sensors. They can be mounted in either surface, pipe or panel configurations.

The IP80 series require special fittings that ensure correct depth placement in the pipe. Fittings come in a variety of materials for compatibility with specific applications. Tee fittings are individually wet-calibrated at the factory and marked with the K-factor (pulses per gallon). Saddle fittings must be field-installed on the pipe and do not come wet-calibrated. K-factors for saddles are based on factory testing.



Applications

- Waste water flow
- Water Treatment systems
- Irrigation
- Groundwater Remediation
- Chemical Mixing
- Process cooling systems
- Neutralization Systems
- Process flow control
- Filtration systems

Model IP80 Series Impeller Flow Sensors Technical Data

Materials

Sensor Body	PVC, Polypro, Brass, or 316 SS
Rotor	PVDF
Shaft	Nickel-bonded tungsten carbide (Ceramic optional)
Bearings	Ruby jewel
O-Ring	EPDM (Viton optional)
Pipe Size	
IP81	1/2" to 3" (12 to 76 mm)
IP82	4" to 8" (100 to 200 mm)
Maximum Pressure	
PVC or Polypro	175 PSI (12 bar) at 75°
Brass	200 PSI (14 bar)
316 SS	250 PSI (17 bar)
Maximum Temperature	
PVC or Polypro	130°F (55°C)*
Brass or SS	200°F (93°C)
Flow Rate	0.3 to 30 FPS (0.1 to 9 M/s)
Accuracy	1-1/2% of full scale
Signal	Hall effect current sinking pulse
Power	6-24 VDC, 2 mA
Maximum Current	20 mA
Cable	#22 AWG 3-con, 18 ft. (6m)

Flow Range (GPM)

	IP81				IP82				
	1/2"	3/4"	1"	1-1/2"	2"	3"	4"	6"	8"
Min	0.28	0.5	0.8	1.9	3.1	6.9	12	27	47
Max	28	50	80	190	314	691	1200	2700	4700

PVC/Polypro Working Pressure vs. Temperature

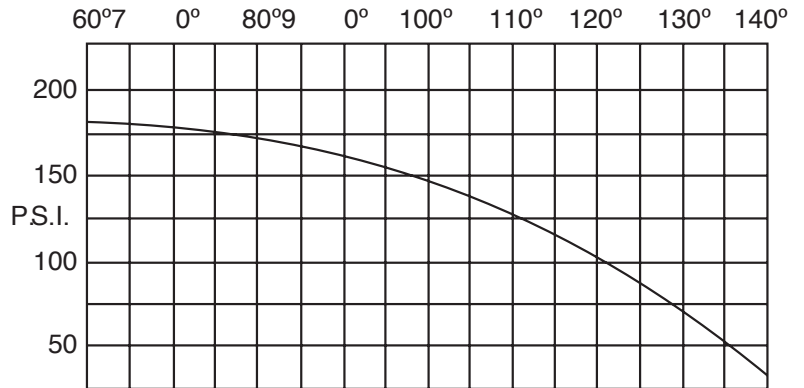

Dimensions

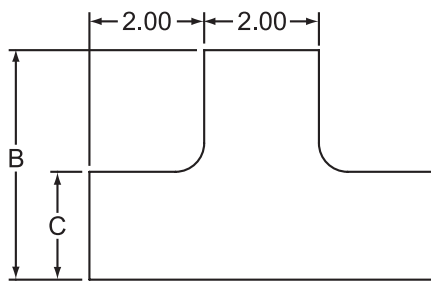
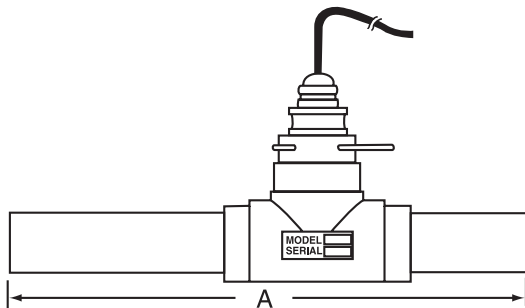

PVC Tee		PVC Block Tee		
Size	Dim. A	Size	Dim. B	Dim. C
1.5"	19.2"	1/2"	1.50"	3.80"
2"	19.9"	3/4"	1.90"	4.00"
		1"	1.88"	4.00"

Order Information

Sensor Style

Impeller sensor (1/2" - 3")	81
Impeller sensor (4" - 6")	82

Sensor Material

PVC	P
Stainless Steel	S
Polypropylene	Y
Brass	B

Mounting Style

1/2" Tee fitting	050
3/4" Tee fitting	075
1" Tee fitting	100
1.5" Tee fitting	150
2" Tee fitting	200
3" Saddle/Weldolet fitting	300
4" Saddle/Weldolet fitting	400
6" Saddle/Weldolet fitting	600

Mounting Tee Material

PVC	P
304 Stainless Steel (available only for 0.5" - 2")	S
Bronze (Not available for 6" pipes)	B