



Description

The complete lack of moving parts of the EX100/200-Series insertion flow sensor is the source of its reliability. Brass and stainless steel models withstand a variety of temperature, pressure, and chemical conditions. The EX-Series has no rotor to stop turning in dirty water and there are no bearings to wear out. Like all meters, when used in chemical injection applications, they should be installed upstream of the chemical line (or far enough downstream to allow complete mixing of fluids before the meter).

A rapidly reversing magnetic field is produced in the lower housing. As the fluid moves through this field, a voltage is generated that is measured and translated into a frequency signal proportional to flow rate. This square wave signal can be sent directly to a PLC or other control or can be converted using the Shark or other controllers and analyzers.

A modular system of electronics can be attached directly to the flow sensor or remotely mounted. The adapter fitting of the EX sensor is standard male NPT, and can be directly threaded into ordinary saddles or threaded weld fittings. The EX115 and 215 (not shown) include an isolation valve, allowing hot-tap installation, or installation and removal under pressure; a bronze ball valve is standard, with a 316 stainless steel valve option if needed.

A hot tap version, reverse flow output and immersibility are all available. Contact Water Analytics for information on these and other options.

Features

- No moving parts
- Durable
- Adjustable depth
- Hot-tap available
- Brass or stainless steel
- Immersibility available
- Reverse flow output available

Applications

- 3" - 48" pipe (up to 72" optional)
- Clean or "dirty" liquids
- Conductive liquids
- Municipal
- Industrial
- Irrigation

Model EX100/200 Series Magmeter Flow Sensors Technical Data

Pipe Size 3" to 48" (up to 72" optional)

Materials

Shaft / Fitting 316 SS or Brass
 Electrodes Hastalloy
 Housing Cast powder-coated aluminum
 Valve Assembly (115/215 only) Bronze (SS optional) with bronze ball valve
 O-Ring EPDM (Viton optional)

Power

Full Power 12 - 25 VDC, 250 mA
 Low Power 12 - 25 VDC, 40 mA average w 250 mA peaks

Flow Rate

0.28 - 20 ft/sec (0.08 - 6.09 m/sec)

Temperature

Ambient Temp 0° to 160° F (-17° to 72° C)
 Fixed Temp: 32° to 200° F (0° to 93° C)
 Brass or SS
 Fluid Temp: PVC 32° to 130° F (0° to 55° C) @ 0 psi

Pressure

200 psi (13.8 bar)
 Maximum conductivity 20 µS/cm
 Calibration Accuracy +/- 1% of full scale
 Output Square wave pulse, opto-isolated, 550 Hz @ 20 ft/sec
 Empty Pipe Detection Software, defaults to zero flow
 Maximum Current 20 mA

Flow Range (GPM)

| Nominal Pipe Size | 3" | 4" | 6" | 8" | 10" | 11" | 12" |
|-------------------|-----|-----|------|------|------|------|------|
| Min | 6 | 11 | 25 | 44 | 69 | 99 | 134 |
| Max | 440 | 783 | 1760 | 3130 | 4890 | 7050 | 9600 |

| Nominal Pipe Size | 16 | 18 | 29 | 24 | 39 | 36 | 48 |
|-------------------|--------|--------|--------|--------|--------|--------|---------|
| Min | 175 | 222 | 274 | 395 | 617 | 888 | 1580 |
| Max | 12,500 | 15,950 | 19,600 | 28,200 | 44,100 | 63,400 | 112,800 |

PVC/Polypro Working Pressure vs. Temperature

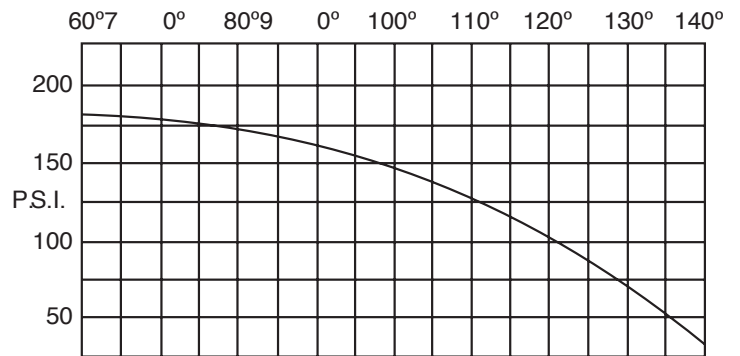

Dimensions

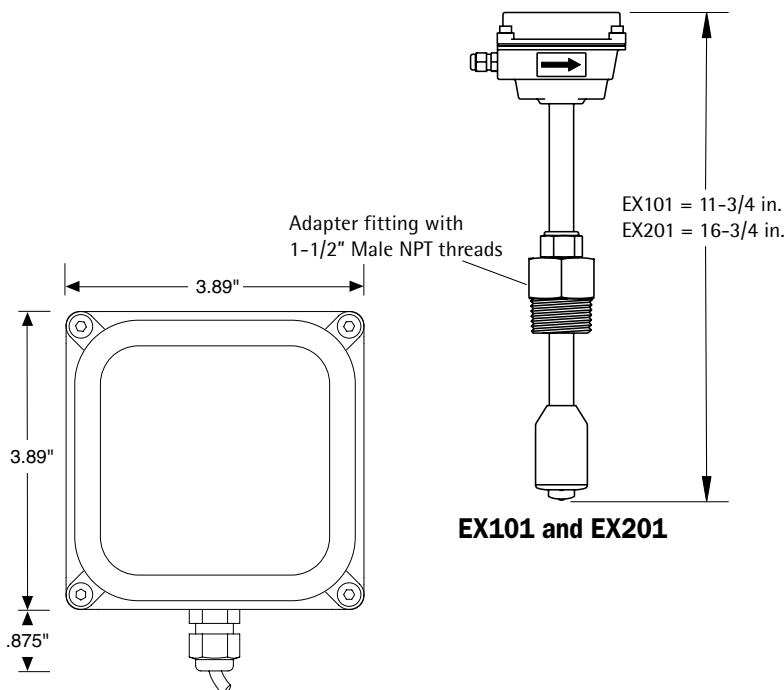

Order Information

Sensor Style

| | |
|------------------------------|------------|
| Impeller sensor (3" - 10") | 100 |
| Impeller sensor (10" - 48") | 200 |

Sensor Material

| | |
|-----------------|----------|
| Stainless Steel | S |
| Brass | B |

Mounting Fitting (Iron only)

| | |
|----------------------------|-------------|
| 3" Saddle fitting (Iron) | 300 |
| 4" Saddle fitting (Iron) | 400 |
| 4" Saddle fitting (Bronze) | 400B |
| 6" Saddle fitting (Iron) | 600 |
| 8" Saddle fitting (Iron) | 800 |
| 10" Saddle fitting (Iron) | 1000 |
| 12" Saddle fitting (Iron) | 1200 |
| 14" Saddle fitting (Iron) | 1400 |
| 16" Saddle fitting (Iron) | 1600 |
| 18" Saddle fitting (Iron) | 1800 |
| 20" Saddle fitting (Iron) | 2000 |
| 24" Saddle fitting (Iron) | 2400 |