

Portable Bulk Containers and Bins

# catalogue



ACO Container Systems Ltd.



# Corporate Profile

Portable Bulk Containers and Bins

## ACO Container Systems

For more than 20 years, ACO has been recognized as one of the leading manufacturers of quality rotationally moulded products.

ACO tanks, moulded in premium grade linear or crosslinked polyethylene, provide a wide range of sizes and capacities to suit all applications.

ACO tanks, moulded products are made under a tough quality control standard to ensure that you get a reliable and consistent product.

ACO tanks provide the toughest tanks available today, capable of withstanding the most stringent tests of strength, reliability and chemical resistance. Polyethylene offers chemical resistance which is superior to FRP, stainless steel and mild steel.

ACO manufactures a complete line of storage tanks, specialty tanks, Transport Canada and United Nations approved shipping containers as well as hopper systems for powder/granular applications. Our tank systems have been serving the chemical process industry, oils/lubricant market, adhesive companies, food and beverage industry and many others successfully over the past 20 years.

ACO also can custom design a system to suit your needs, our staff is here to help you. To get more in-depth answers to your questions please contact your local ACO representative.



## table of contents

Corporate Profile	2
Table of Contents	3
Pallet Tanks	4-7
Pallet Hoppers	8
Quick Discharge Pallet Tanks	9
Sloped Bottom Tanks	10
Conical Bottom Tanks	11
Closed Top Storage Tanks	12-13
Open Top Storage Tanks	14-15
Double Wall Storage Tanks	16
Secondary Containment Basins	17
Horizontal Tanks	18
Tote Barrels, Round Tanks	19
Fittings & Accessories	20
Structural Drawings: Closed Top Storage Tank	21
Conical Bottom Tank	22
Open Top Storage Tank	23

# pallet

# tanks

ACO Pallet Tanks are the most economical and environmentally friendly reusable IBC's. The advanced design ensures complete drainage.



**UN approved for Transportation of Dangerous Goods**

Code No.	Length	Width	Height	Imp. Gallons	Litres
PTC-125	48"	40"	43"	125	570
PTC-200	48"	40"	54"	200	910
PTC-250	48"	40"	63"	250	1130
PTC-270	48"	40"	63"	270	1225
PTC-330	49"	49"	66"	330	1500
PT-450	48"	40"	91"	450	2040

Specific gravity 1.7 standard, 1.9 available upon request. All dimensions and measurements are approximate.

pallet

# tanks

ACO Pallet Tanks with heavy duty, fully enclosed steel frames offer excellent protection. Ideal for harsh environment.



UN approved for Transportation of Dangerous Goods

Code No.	Length	Width	Height	Imp. Gallons	Litres
PTC-125	48"	40"	43"	125	570
PTC-200	48"	40"	54"	200	910
PTC-250	48"	40"	63"	250	1130
PTC-270	48"	40"	63"	270	1225
PTC-330	49"	49"	66"	330	1500

Specific gravity 1.7 standard, 1.9 available upon request.  
All dimensions and measurements are approximate.

pallet

tanks

ACO Pallet Tanks low profile design offers double stacking during Transportation. Large 10" threaded opening designed for unique applications.



UN approved for Transportation of Dangerous Goods

Code No.	Length	Width	Height	Imp. Gallons	Litres
PTC-250 LP	54"	45"	53"	250	1130

All dimensions and measurements are approximate.

pallet

# tanks

ACO Containers offers another first in the industry, the narrow profile Pallet Tank. Designed to be moved through narrow doorways (30").



ACO Containers offered the first double tank design in the industry. Allows for two separate products in one shipment.



UN approved for Transportation of Dangerous Goods

Code No.	Length	Width	Height	Imp. Gallons	Litres
PTC-135	40"	26"	65"	135	610
PTC-2/135	40"	48"	65"	270	1220

All dimensions and measurements are approximate.

pallet

# hoppers

ACO Pallet Hoppers are designed for granular and powder applications. Sliding gate valves for fast and efficient discharge.



Code No.	Length	Width	Height	Imp. Gallons	Litres
PH-1000	56"	48"	69"	225	1000
PH-2000	56"	48"	91"	450	2000

All dimensions and measurements are approximate.

pallet

# tanks

ACO QD (Quick Discharge) Pallet Tanks are designed to ship viscous liquids and allow for quick and complete drainage.



Code No.	Length	Width	Height	Imp. Gallons	Litres
PT-185 QD	48"	40"	64"	185	840
PT-220 QD	48"	40"	67"	220	1000
PT-240 QD	48"	40"	69"	240	1080
PT-250 QD	48"	40"	71"	250	1130

All dimensions and measurements are approximate.

# sloped bottom

# tanks

- Advanced design ensures complete drainage
- Excellent chemical & corrosion resistance
- Durable, one-piece seamless construction
- Self supporting
- U.V. stabilized for sunlight protection



Code No.	Capacity		Diameter incl. base	Height incl. base	Manway
	Imp. Gallons	Litres			
SB 300	300	1360	47"	75"	10"
SB 400	400	1810	47"	103"	10"
SB 800	800	3630	76"	74"	10"/14"/21"
SB 1000	1000	4500	76"	89"	10"/14"/21"
SB 1250	1250	5600	76"	104"	10"/14"/21"

All dimensions and measurements are approximate.

# conical bottom

# tanks



- Excellent chemical & corrosion resistance
- Total drainage
- Durable, one-piece seamless construction
- Based on specific gravity of 1.5 (1.9 or 2.2 available upon request)
- Manufactured from LLDPE (linear Polyethylene) XLPE - (cross-linked Polyethylene) available

CBO=Cone Bottom/  
Open Top Tank  
CBC=Cone Bottom/  
Closed Top Tank  
CBS=Cone  
(Silo) Bottom/  
Closed Top Tank

Code No.	Capacity		Diameter	Overall Height	Wall Thickness	Weight Tank/Stand	Manway
	Imp. Gal.	Litres					
CBO-30	30	136	16"	63"	.188"	13 lbs./45 lbs.	LID
CBO-45	45	200	22"	60"	.188"	22 lbs./50 lbs.	LID
CBO-125	125	560	30"	70"	.250"	44 lbs./80 lbs.	LID
CBO-250	250	1100	40"	87"	.250"	115 lbs./110 lbs.	LID
CBO-500	500	2200	55"	90"	.333"	150 lbs./180 lbs.	LID
CBO-750	750	3400	70"	86"	.375"	220 lbs./551 lbs.	LID
CBO-1000	1000	4500	70"	105"	.375"	260 lbs./551 lbs.	LID
CBC-1300	1300	5800	86"	121"	.500"	450 lbs./440 lbs.	16"
CBC-1800	1830	8300	96"	119"	.500"	700 lbs./440 lbs.	24"
CBC-2100	2100	9500	86"	159"	.500"	700 lbs./440 lbs.	16"/21"
CBC-2500	2500	11300	90"	154"	.500"	825 lbs./450 lbs.	16"/21"
CBC-3500	3500	15500	98"	175"	.500"	850 lbs./550 lbs.	21"
CBS-1000	1000	4500	70"	123"	.500"	300 lbs./575 lbs.	14"
CBS-1250	1250	5600	70"	138"	.500"	350 lbs./680 lbs.	15"
CBS-1500	1500	6800	70"	157"	.500"	400 lbs./775 lbs.	14"
CBC-5000	5000	22000	143"	160"	Consult Factory	Consult Factory	24"
CBC-6500	6500	29500	143"	195"	Consult Factory	Consult Factory	24"

All dimensions and measurements are approximate.

# closed top storage

# tanks

- Excellent chemical & corrosion resistance
- Durable, one-piece seamless construction
- Narrow diameters for economical in-plant use
- U.V. stabilized for sunlight protection
- Self supporting
- Custom accessories to your specifications



Code No.	Capacity		Diameter	Height	Weight	Manway
	Imp. Gallons	Litres				
CT-70	70	310	24"	48"	37 lbs.	14"
CT-100	100	450	31"	42"	40 lbs.	12"
CT-120	120	540	31"	56"	50 lbs.	14"
CT-150	150	680	31"	58"	60 lbs.	12"
CT-225	225	1000	31"	87"	80 lbs.	12"
CT-300*	300	1360	48"	54"	110 lbs.	14"
CT-310	310	1400	55"	43"	115 lbs.	14"

All dimensions and measurements are approximate.

# closed top storage

# tanks

- All dimensions are in inches (approx.)
- Based on specific gravity of 1.5 (1.9 or 2.2 available upon request)
- Manufactured from LLDPE (linear Polyethylene) XLPE - (cross-linked Polyethylene) available

Code No.	Capacity		Diameter	Height	Weight	Manway
	Imp. Gallons	Litres				
CT-400	400	1800	55"	54"	130 lbs.	14"
CT-450*	450	2000	48"	87"	135 lbs.	14"
CT-500*	500	2200	48"	92"	150 lbs.	14"
CT-510	500	2200	55"	68"	150 lbs.	14"
CT-600*	600	2700	48"	103"	175 lbs.	14"
CT-700*	700	3100	48"	120"	190 lbs.	14"
CT-750	750	3400	70"	63"	220 lbs.	14"
CT-800	800	3600	64"	84"	235lbs.	14"
CT-1000	1000	4500	64"	103"	280 lbs.	14"
CT-1010	1000	4500	70"	78"	280 lbs.	14"
CT-1230	1250	5600	64"	123"	300 lbs.	16"
CT-1250	1250	5600	70"	97"	325 lbs.	14"
CT-1650	1670	7500	86"	100"	350 lbs.	16"
CT-1700	1700	7500	64"	165"	450 lbs.	16"
CT-2000	2000	9000	85"	115"	550 lbs.	14"/15"
CT-2450	2450	11000	90"	126"	620 lbs.	Threaded 21"
CT-3300	3300	15000	90"	162"	850 lbs.	Threaded 21"
CT-3500	3500	15500	96"	152"	850 lbs.	Threaded 21"
CT-4300	4300	19500	105"	150"	1050 lbs.	Top Hinged 24"
CT-4500	4500	20000	119"	141"	Consult factory	Top Hinged 24"
CT-4600	4600	20000	96"	196"	1400 lbs.	Top Hinged 24"
CT-5300	5400	24000	104"	193"	1600 lbs.	Top Hinged 24"
CT-5400	5400	24000	120"	156"	Consult factory	Top Hinged 24"
CT-6500	6500	29000	143"	142"	Consult factory	Top Hinged 24"
CT-8000	8000	36000	143"	173"	Consult factory	Top Hinged 24"
CT-10000	10000	45000	143"	196"	Consult factory	Top Hinged 24"

\* Different top configurations available.  
All dimensions and measurements are approximate.

# open top storage

# tanks

- Excellent chemical & corrosion resistance
- Narrow diameters for economical in-plant use
- U.V. stabilized for sunlight protection
- Custom accessories to your specifications



Code No.	Capacity		Dimension in Dia.x Height	Wall Thickness	Weight	LID Available
	Imp. Gallons	Litres				
OT-5	5	22	11"x 18"	.125"	4.4 lbs.	Yes
OT-9	9	40	15"x 16"	.125"	5.5 lbs.	No
OT-15	15	68	16"x 23"	.125"	6.6 lbs.	Yes

# open top storage

# tanks

- All dimensions are in inches (approx.)
- Manufactured from LLDPE (linear Polyethylene) XLPE - (cross-linked Polyethylene) available

Code No.	Capacity		Dimension in Dia.x Height	Wall Thickness	Weight	LID Available
	Imp. Gallons	Litres				
OT-17	17	77	18" x 21"	.188"	10 lbs.	No
OT-25	25	110	16" x 36"	.188"	11 lbs.	Yes
OT-30	30	136	18" x 37"	.188"	12 lbs.	Yes
OT-36	36	160	18" x 39"	.188"	13 lbs.	Yes
OT-45	45	200	22" x 36"	.188"	22 lbs.	Yes
OT-50	50	220	22" x 40"	.188"	24 lbs.	Yes
OT-60	60	270	22" x 44"	.188"	26 lbs.	Yes
OT-66	66	300	26" x 38"	.188"	30 lbs.	Yes
OT-75	75	340	24" x 47"	.250"	30 lbs.	Yes
OT-100	100	450	30" x 45"	.250"	38.5 lbs.	Yes
OT-125	125	560	30" x 49"	.250"	44 lbs.	Yes
OT-150	150	680	37" x 45"	.250"	52 lbs.	Yes
OT-175	175	790	36" x 49"	.250"	65 lbs.	Yes
OT-178	178	800	30" x 73"	.250"	68 lbs.	Yes
OT-220	220	1000	55" x 34"	.250"	100 lbs.	Yes
OT-240	240	1080	43" x 50"	.250"	95 lbs.	Yes
OT-300A	300	1360	48" x 50"	.375"	110 lbs.	Yes
OT-300B	300	1360	55" x 41"	.375"	125 lbs.	Yes
OT-400	400	1800	55" x 50"	.375"	143 lbs.	Yes
OT-500	500	2200	55" x 62"	.375"	150 lbs.	Yes
OT-750	750	3400	70" x 58"	.375"	247 lbs.	Yes
OT-1000	1000	4500	70" x 78"	.375"	280 lbs.	Yes
OT-1250	1250	5600	70" x 93"	.375"	350 lbs.	Yes

All dimensions and measurements are approximate.

# double wall storage

# tanks

ACO Double Wall Storage Tanks allow you to address all your environmental and safety concerns. Space saving design and self supporting.



Code No.	Diameter	Height	Imp. Gallons	Litres
DWE-510	70"	78"	510	2200
DWE-800	70"	96"	800	3600
DWE-1000	86"	114"	1000	4500
DWE-1250	86"	100"	1250	5600
DWE-1650	90"	122"	1650	7500
DWE-2000	90"	122"	2000	9000
DWE-2450	96"	152"	2450	11000
DWE-3300	96"	196"	3300	15000
DWE-4500	143"	142"	4500	20000
DWE-5400	143"	173"	5400	24000

All these sizes are available in open top outer containment configuration.  
All dimensions and measurements are approximate.

# secondary containment

## basins

ACO Secondary Containment Basins enable you to comply with current environmental regulations. Designed for all ACO Tanks.

- Manufactured from LLDPE (linear Polyethylene) XLPE - (cross-linked Polyethylene) available



Code No.	Capacity		Length	Width	Height
	Imp. Gallons	Litres			
IRD-40	40	180	31"	21"	12"
IRD-90	95	430	46"	31"	21"
IRD-165	165	750	59"	37"	28"
IRD-185	185	800	69"	44"	25"
IRD-310	310	1400	68"	68"	24"
IRD-410	410	1800	69"	69"	30"
IRD-800	800	3600	82"	70"	46"
IRD-1375	1375	6200	99"	99"	53"
IRD-1450	1450	6500	218"	108"	21"
IRD-2900	2900	13000	218"	108"	40"

All dimensions and measurements are approximate.

# horizontal

# tanks



- Manway openings for easy access
- Durable, one-piece seamless construction
- U.V. stabilized for sunlight protection
- Custom accessories to your specifications
- Based on specific gravity of 1.5
- Manufactured from LLDPE (linear Polyethylene)  
XLPE - (cross-linked Polyethylene) available

Code No.	Capacity		Diameter	Length	Manway
	Imp. Gallons	Litres			
IHFS-45	45	200	25"	33"	6"
IHFS-90	90	400	30"	46"	6"
IHFS-125	125	570	32"	40"	6"
IHFS-170	170	770	37"	45"	6"
IHFS-250	250	1100	37"	67"	6"
IHFS-415	415	1800	47"	67"	8"
IHT-835	835	3700	48"	140"	16"
IHT-1375	1375	6200	60"	157"	16"
IHT-2085	2085	9400	64"	191"	16"

All dimensions and measurements are approximate.

# tote barrels

PTB Series Tanks are designed to mount pumping equipment.



Code No.	Litres	Imp. Gallons	Diameter Ins.	Height Ins.
PTB-60	60	13	15"	28"
PTB-100	100	22	18"	29"
PTB-200	200	44	22"	39"
PTB-300	300	66	26"	44"
PTB-400	400	88	30"	43"

All dimensions and measurements are approximate.

# round tanks

ACO Round Tanks for custom applications.



Code No.	Litres	Imp. Gallons	Diameter Ins.	Length Ins.	Height Ins.
RT-40	40	9	15"	18"	16"
RT-100	100	22	20"	27"	18"
RT-300	300	66	27"	37"	27"
RT-500	500	110	30"	45"	32"

All dimensions and measurements are approximate.

# fittings & accessories



Ball Valves



Quick Disconnect



Welded Connections

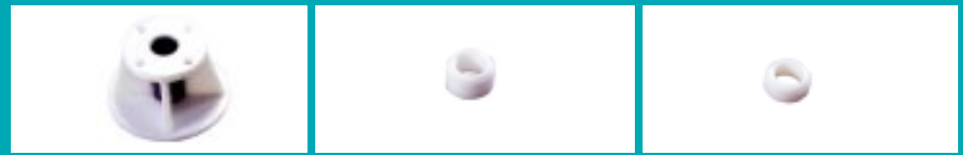

Flanged Connections



Bulkhead Fittings



Combination Vents



Manway Lids



Threaded Lids



# closed top storage

## tanks

1. Top configuration for these closed top tanks:  
CT-310, 400, 510, 750, 1010, & 1250.
2. Top configuration for these closed top tanks:  
CT-100, 150, 300, 450, 500, 600, & 700.
3. Top configuration for these closed top tanks:  
CT-100, 150, 225, 300, 450, 500, 600, & 700.

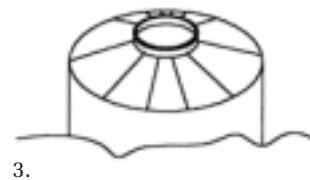
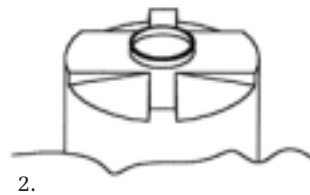
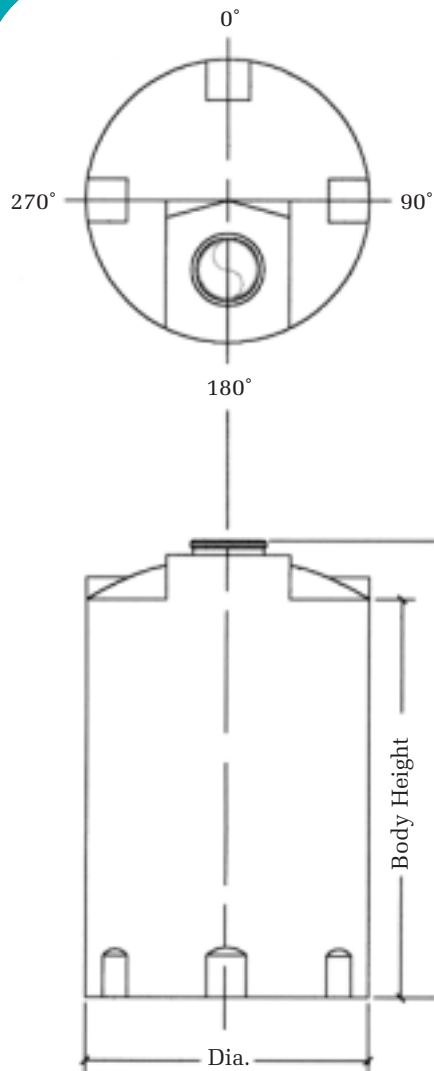

Photocopy before adding fitting locations.

# cone bottom

# tanks

1. Top configuration for these cone bottom tanks:  
CBO-30, 45, 125, 500, 750, & 1000.
2. Top configuration for these cone bottom tanks:  
CBS-1000, 1250, & 1500.

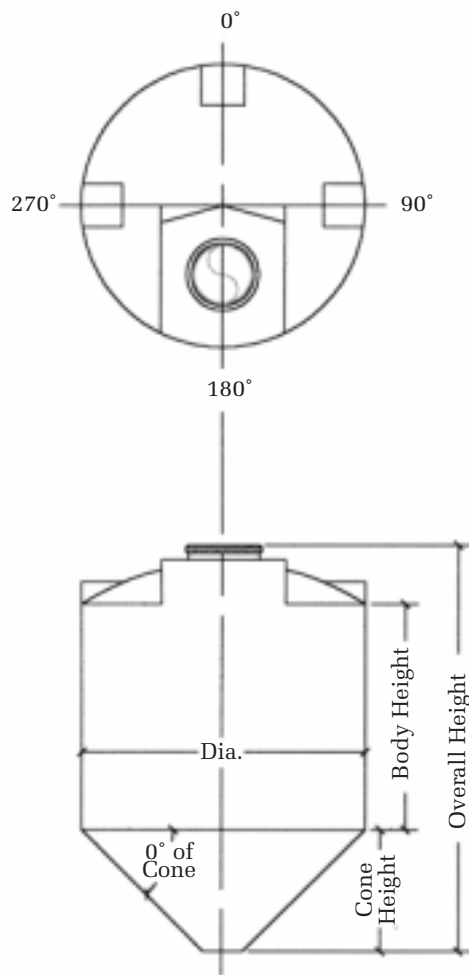

Photocopy before adding fitting locations.

open top

# tanks

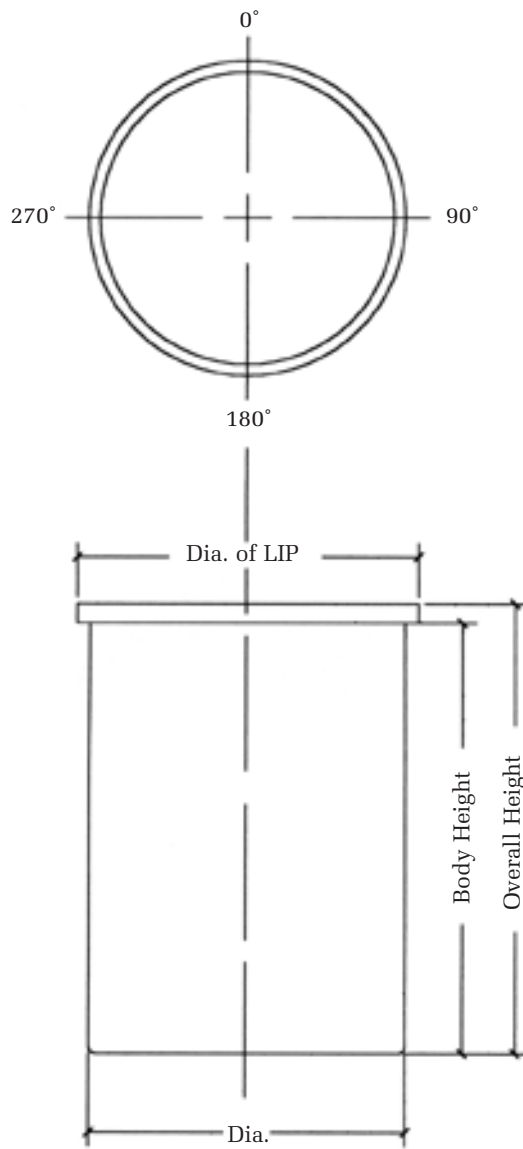

Photocopy before adding fitting locations.



ACO Container Systems Ltd.