

NOTES:

1. TANK IS MANUFACTURED TO ASTM-D-1998 STANDARD.
2. ALL DIMENSIONS ARE APPROXIMATE.

MATERIALS LIST		
ITEMS	DESCRIPTION	NOTES
A	PTB-100 TOTE BARREL	
B	5 1/2" THREADED LID	

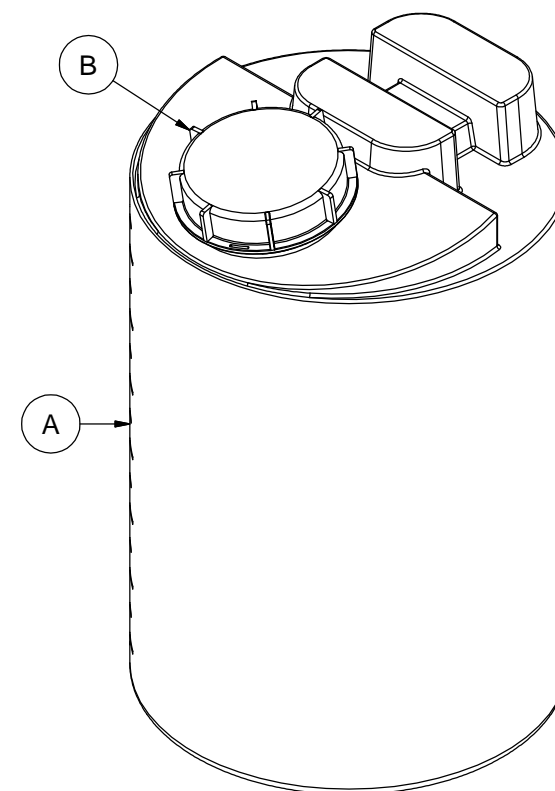
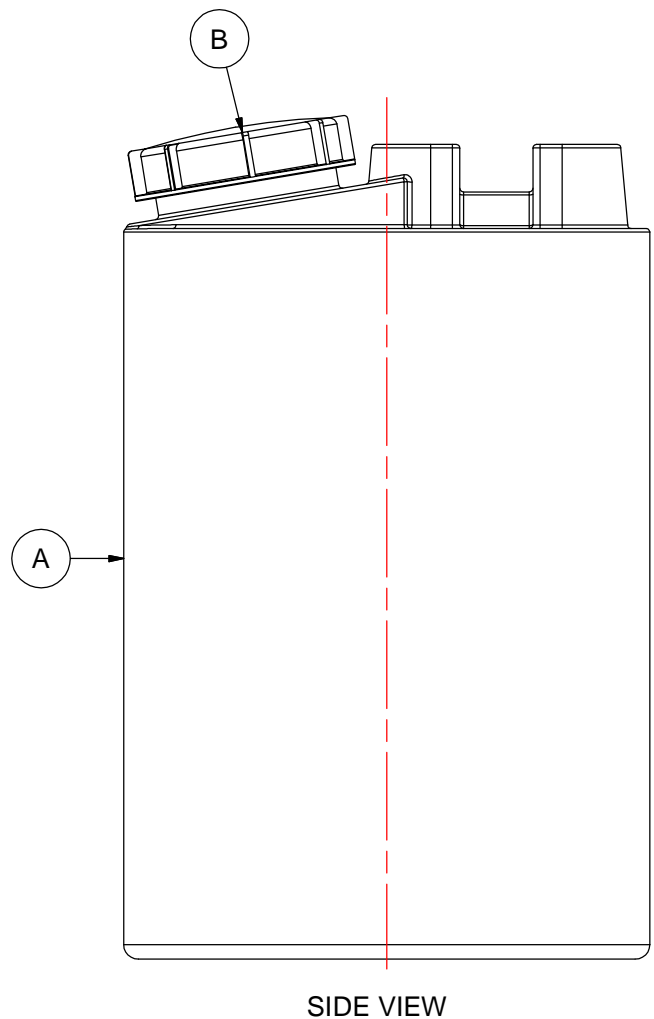
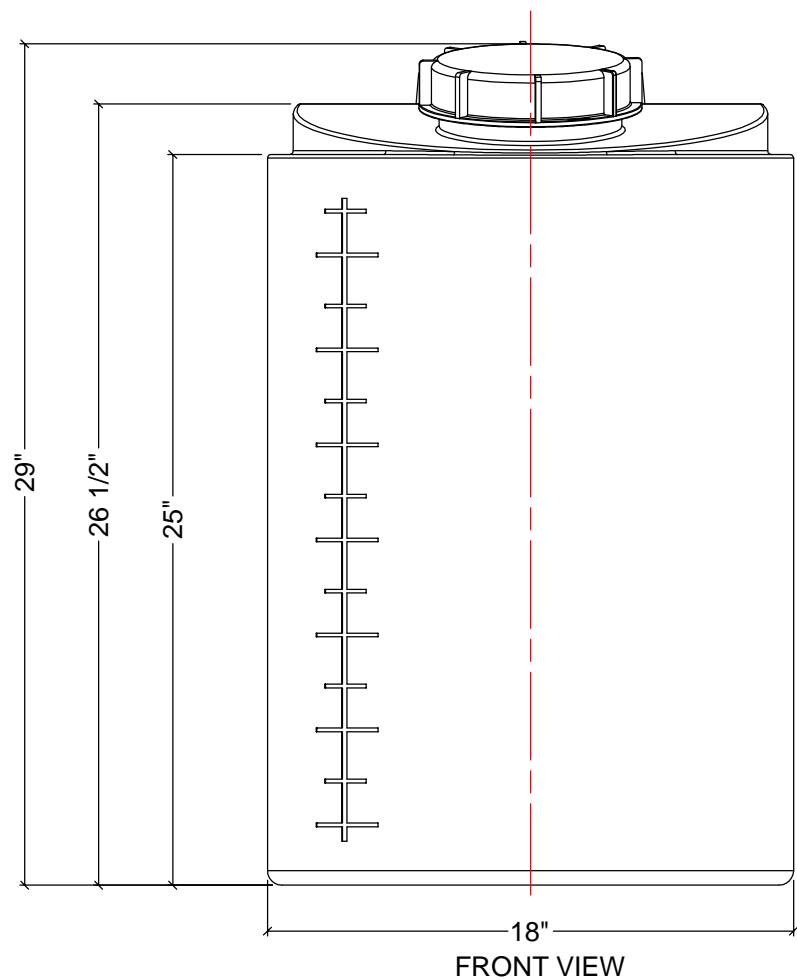

REV	DATE	DESCRIPTION	BY	APPD	REVD
REVISIONS					
CUSTOMER					
TITLE			ACO JOB NO:		
100 LITRE TOTE BARREL			PURCHASE ORDER NO:		
			PURCHASER'S EQUIP. NO:		
THIS DRAWING IS THE PROPERTY OF ACO CONTAINER SYSTEMS LTD. AND SHALL NOT BE COPIED OR TRANSFERRED WITHOUT THE WRITTEN CONSENT OF ACO CONTAINER SYSTEMS LTD.					
ENGINEERS SEAL			<b>ACO CONTAINER SYSTEMS LTD.</b> <small>PICKERING - ONTARIO - CANADA</small> ACO CONTAINER SYSTEMS LTD. 794 MCKAY RD. PICKERING, ONTARIO, CANADA L1W 2Y4 TEL. 905-683-8222 FAX 905-683-2969		
DWG No			PTB-100		REV 0
DESIGNED			WM		
DRAWN					
CHECKED					
APPROVED					
SCALE			N.T.S.		
DATE			19-05-09		