

NOTES:

1. CAPACITY: 125 IMP GAL (570 L)
2. TARE WEIGHT: 350 LBS (150 KG)
3. PRIMARY MARKINGS: U.N. 31HA1/Y/

STACKING BRACKET DETAIL (H)

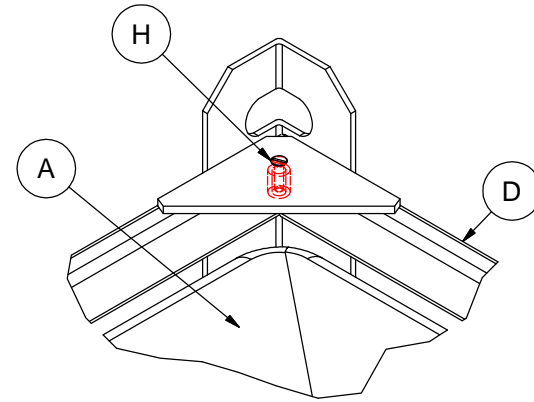

MATERIALS LIST		
ITEMS	DESCRIPTION	NOTES
A	PTC-125 HDPE BOTTLE	
B	6" ORANGE HDPE THREADED LID WITH GASKET AND TIE DOWN (EPDM OR VITON)	
C	2" COMBI-VENT - VACUUM AND PRESSURE RELEIF (OPTIONAL)	IN LID
D	STEEL FRAME WITH 9" KICKPLATES AND VALVE PROTECTION GATE	
E	2" BALL VALVE (POLYPRO OR STAINLESS STEEL) WITH GASKET (EPDM OR VITON)	FNPT OR CAMLOC
F	VALVE MOUNTING HARDWARE KIT	
G	BLACK POLY FRAME PILLOW	
H	FRAME CORNER STACKING BRACKET W/ SCREW	4 PLACES
J	ALUMINUM U.N. FRAME TAG	

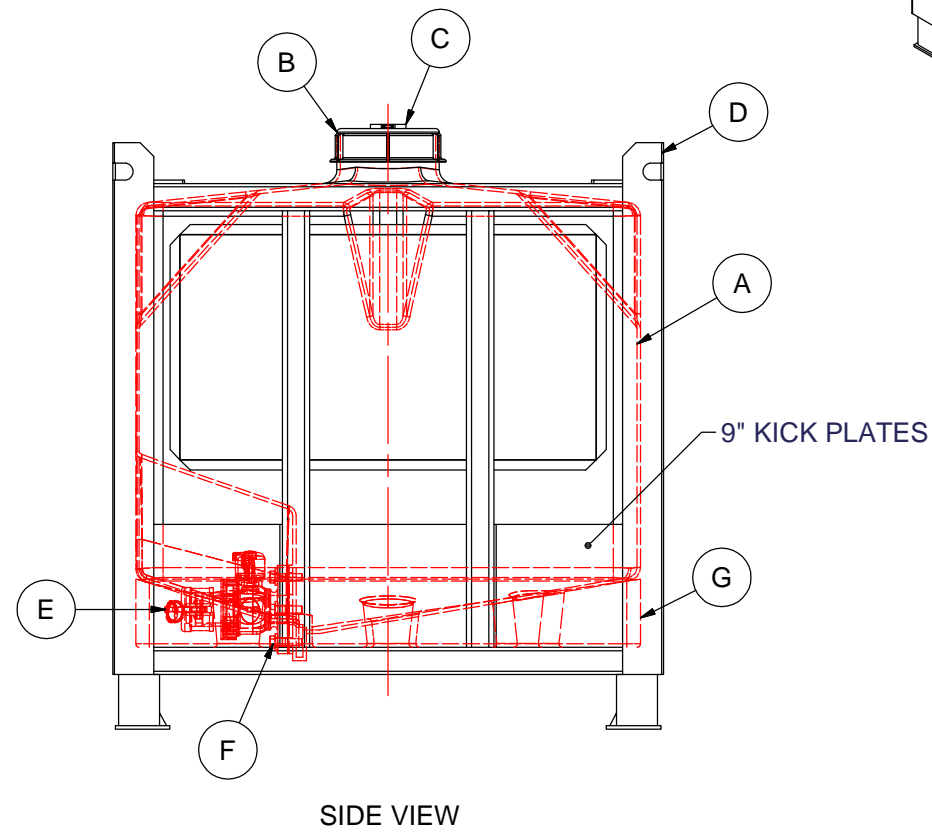
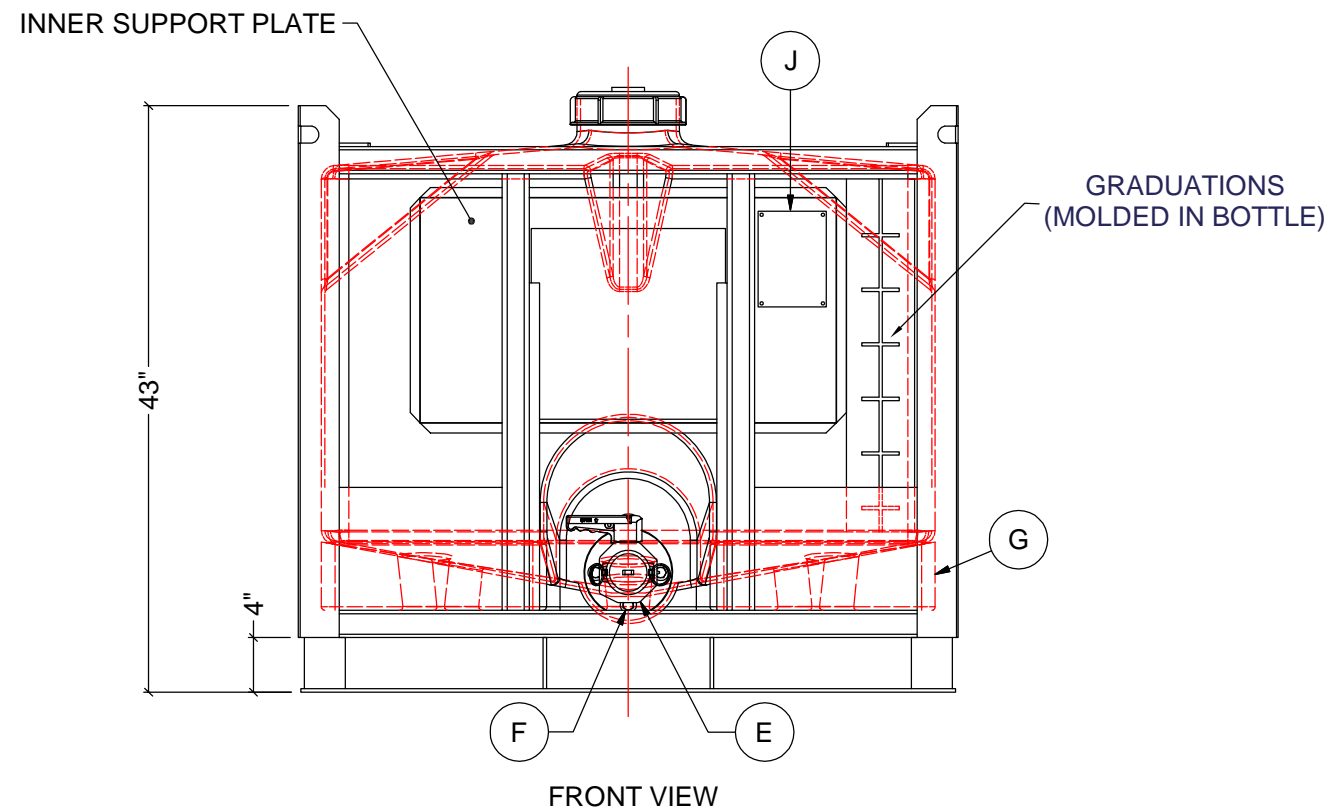
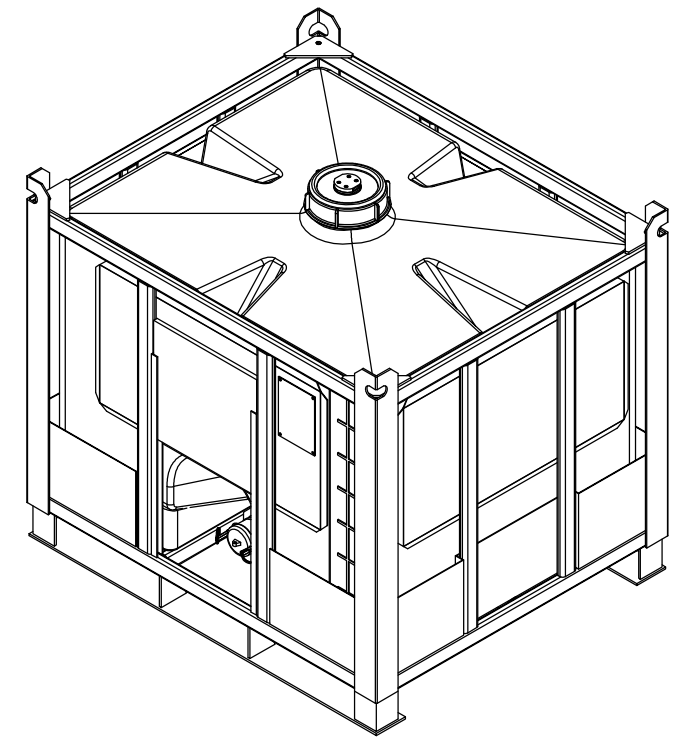

REV	DATE	DESCRIPTION	BY	APPD	REVD
REVISIONS					
CUSTOMER					
TITLE PTC-125 WITH 9" KICK PLATES			ACO JOB NO: PURCHASE ORDER NO: PURCHASER'S EQUIP. NO:		
THIS DRAWING IS THE PROPERTY OF ACO CONTAINER SYSTEMS LTD. AND SHALL NOT BE COPIED OR TRANSFERRED WITHOUT THE WRITTEN CONSENT OF ACO CONTAINER SYSTEMS LTD.					
ENGINEERS SEAL			<b>ACO CONTAINER SYSTEMS LTD.</b> <small>PICKERING - ONTARIO - CANADA</small> ACO CONTAINER SYSTEMS LTD. 794 MCKAY RD. PICKERING, ONTARIO, CANADA L1W 2Y4 TEL. 905-683-8222 FAX 905-683-2969		
DESIGNED DRAWN CHECKED APPROVED SCALE DATE					
DWG No PTC-125			N.T.S. 15-10-09 REV 0		