

NOTES:  
 1. TANK IS MANUFACTURED TO ASTM-D-1998 STANDARD.  
 2. ALL DIMENSIONS ARE APPROXIMATE.

MATERIALS LIST		
ITEMS	DESCRIPTION	NOTES
A	DMT-900 INSIDE TANK	
B	DMT-900 OUTSIDE TANK	
C	16" LID WITH LOCKING STRAP	

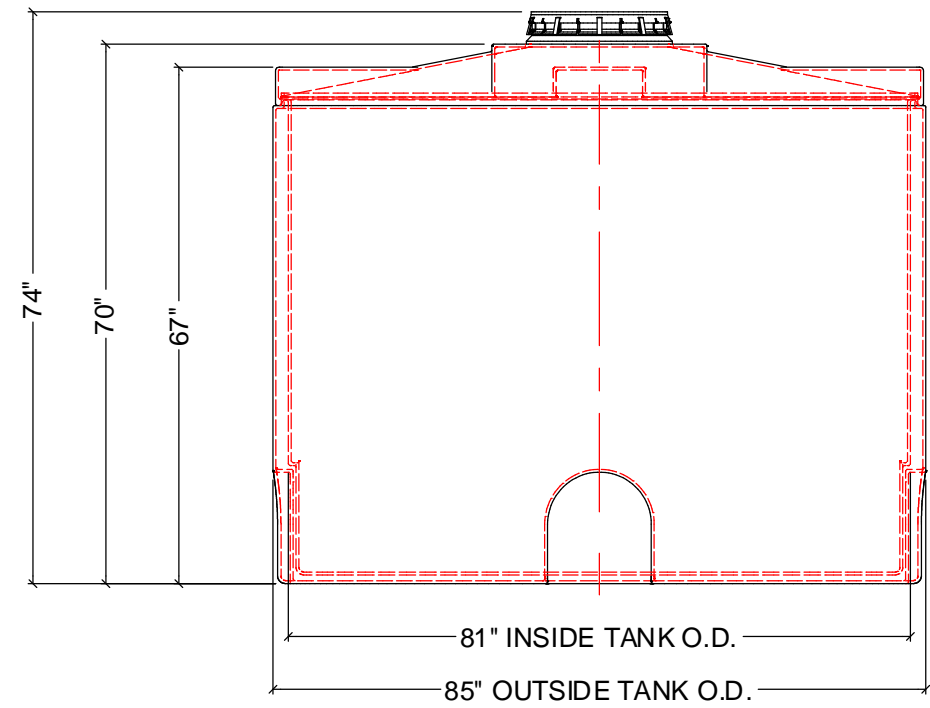

FRONT VIEW

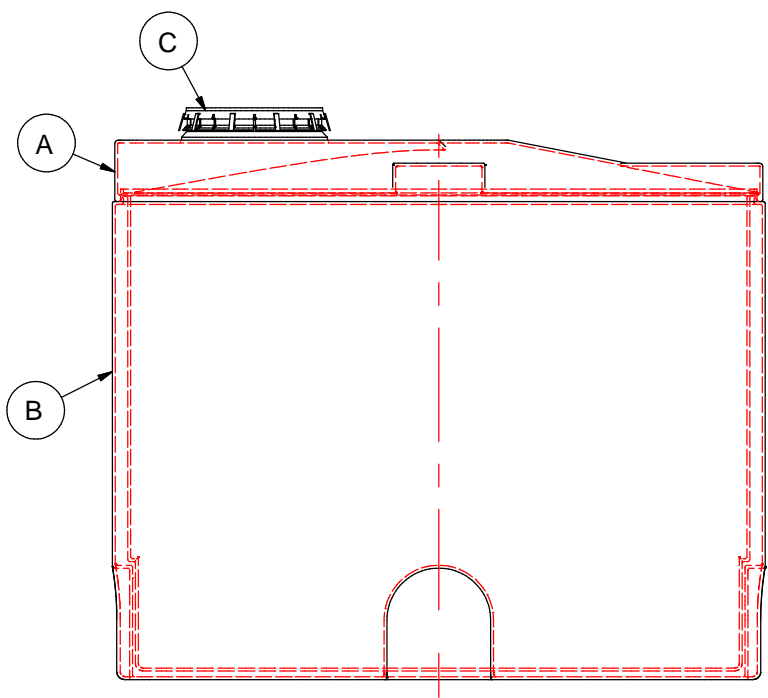

SIDE VIEW

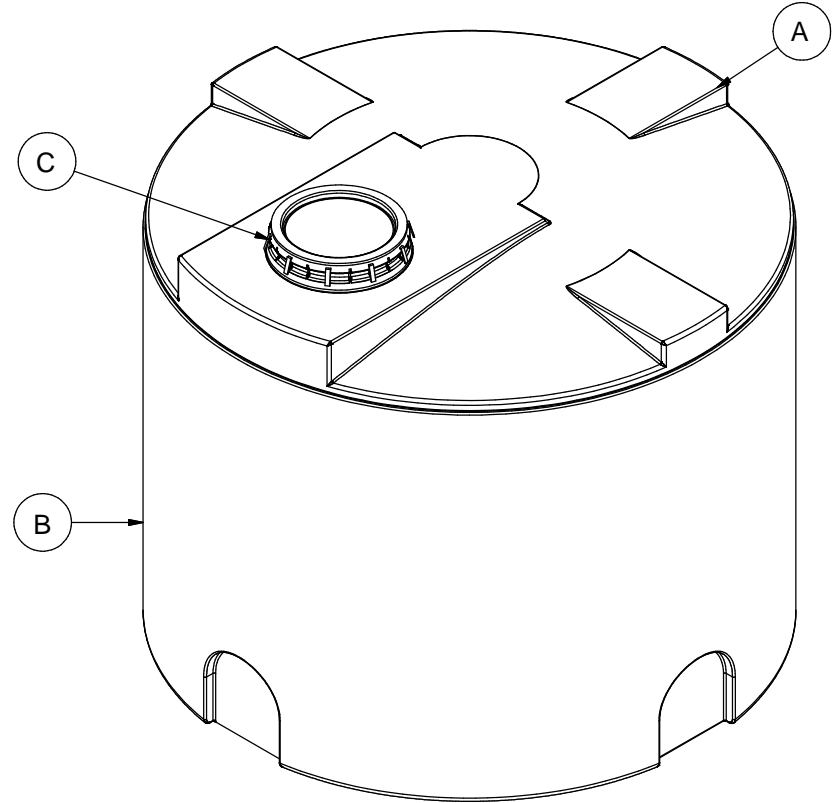

REV	DATE	DESCRIPTION	BY	APPD	REVD
REVISIONS					
CUSTOMER					
TITLE		ACO JOB NO:			
DMT-900 DOUBLE WALL TANK		PURCHASE ORDER NO:			
		PURCHASER'S EQUIP. NO:			
THIS DRAWING IS THE PROPERTY OF ACO CONTAINER SYSTEMS LTD. AND SHALL NOT BE COPIED OR TRANSFERRED WITHOUT THE WRITTEN CONSENT OF ACO CONTAINER SYSTEMS LTD.					
ENGINEERS SEAL		<b>ACO CONTAINER SYSTEMS LTD.</b>			
		<small>PICKERING - ONTARIO - CANADA</small>			
		<small>ACO CONTAINER SYSTEMS LTD.</small>		<small>DESIGNED</small>	
		<small>794 MCKAY RD.</small>		<small>DRAWN</small>	
		<small>PICKERING, ONTARIO, CANADA</small>		<small>CHECKED</small>	
		<small>L1W 2Y4</small>		<small>APPROVED</small>	
		<small>TEL. 905-683-8222</small>		<small>SCALE</small>	
		<small>FAX 905-683-2969</small>		<small>DATE</small>	
		<small>DWG No</small>		<small>REV</small>	
		<b>DMT-900</b>		<b>0</b>	