

NOTES:

1. TANK IS MANUFACTURED TO ASTM-D-1998 STANDARD.
2. ALL DIMENSIONS ARE APPROXIMATE.

MATERIALS LIST		
ITEMS	DESCRIPTION	NOTES
A	DMT-100-OUTSIDE TANK	
B	DMT-100-INSIDE TANK	
C	6" THREADED LID	

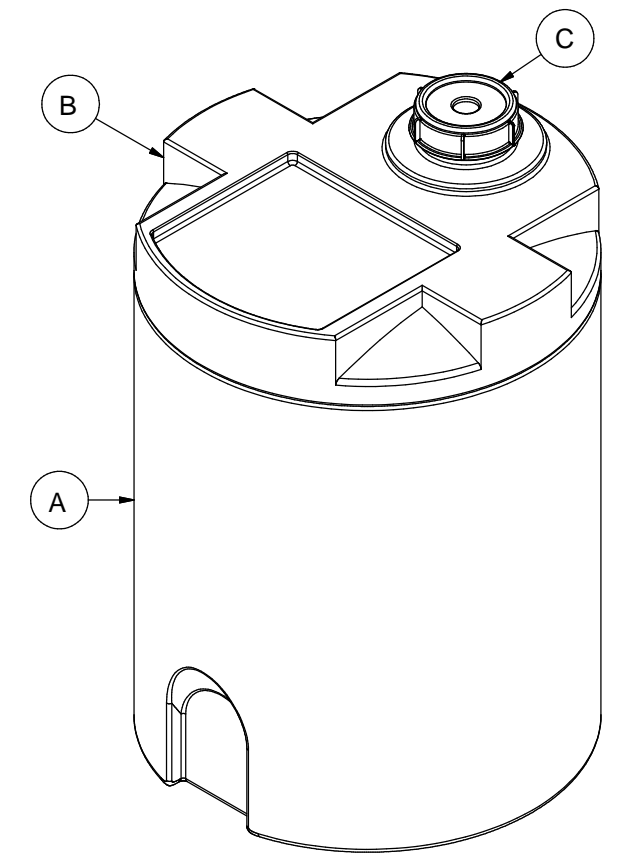
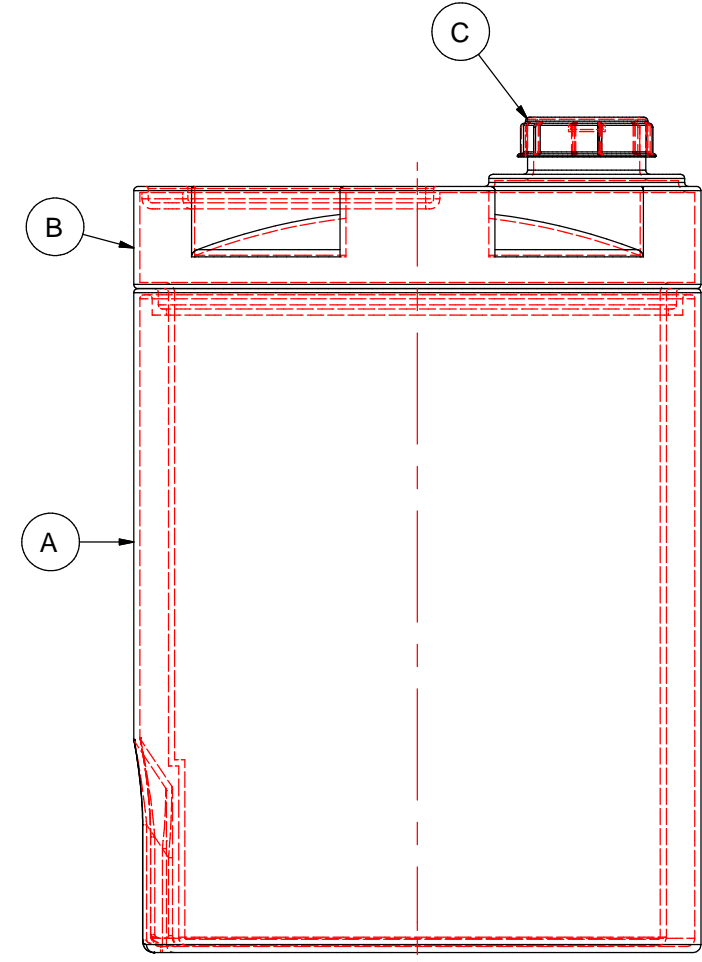
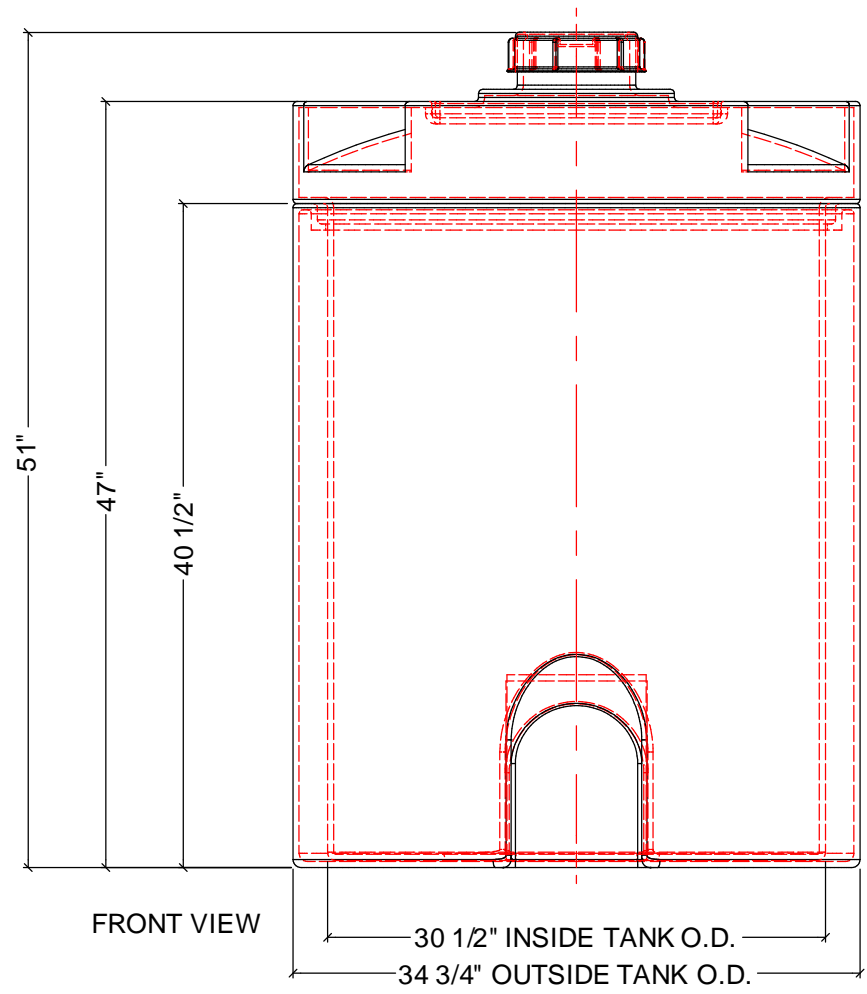

REV	DATE	DESCRIPTION	BY	APPD	REVD
REVISIONS					
CUSTOMER					
TITLE			ACO JOB NO:		
100 I.G. DOUBLE WALL TANK			PURCHASE ORDER NO:		
			PURCHASER'S EQUIP. NO:		
THIS DRAWING IS THE PROPERTY OF ACO CONTAINER SYSTEMS LTD. AND SHALL NOT BE COPIED OR TRANSFERRED WITHOUT THE WRITTEN CONSENT OF ACO CONTAINER SYSTEMS LTD.					
ENGINEERS SEAL		ACO CONTAINER SYSTEMS LTD.			
<small>PICKERING - ONTARIO - CANADA</small>					
<small>ACO CONTAINER SYSTEMS LTD. 794 MCKAY RD. PICKERING, ONTARIO, CANADA L1W 2Y4 TEL. 905-683-8222 FAX 905-683-2969</small>				DESIGNED	WM
				DRAWN	
				CHECKED	
				APPROVED	
				SCALE	N.T.S.
				DATE	18-01-10
DWG No		DMT-100		REV	0