

PPS PUMPS

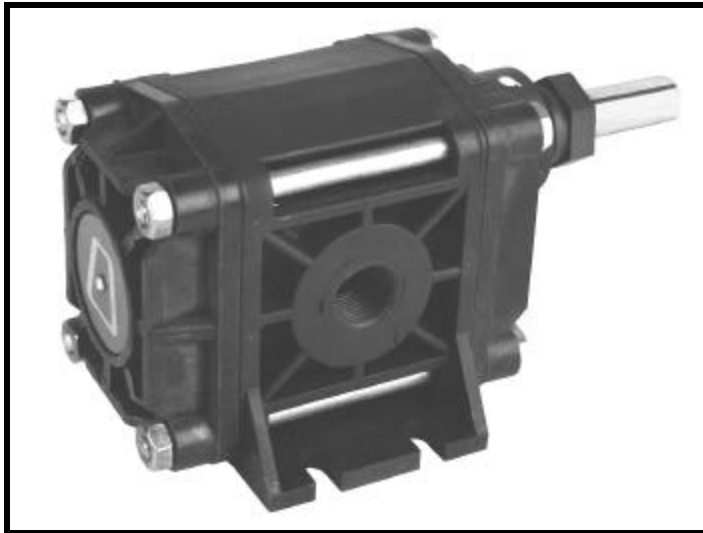

OBERDORFER PUMPS
A Subsidiary of Thomas Industries Inc.

SPECIFICATIONS



Maximum Discharge Pressure:	75 psi for 205 and 207 series 50 psi for 214 series
Suction Lift:	18 in Hg max
Shaft Speed:	400 to 1800 rpm
Temperature:	-20 to 180°F
Fluid Viscosity:	30 to 500,000 SSU
Port Sizes (NPT):	3/8" & 1/2" for series 205 and 207 1/2" & 3/4" for series 214

GENERAL INFORMATION

Oberdorfer's PPS pumps feature injection molded reinforced polyphenylene sulfide (PPS) plastic housing. This pump has become a popular cost-effective alternative to metal pumps in chemical pump applications. PPS is an engineered reinforced plastic offering a wide range of chemical compatibility, physical stability and high temperature resistance (to 180° F). Glass fibers are also combined to add strength and stability. Housing have special designed ribbing and heavy wall sections. Oberdorfer's building block design permits ease of servicing and parts replacement.

Quiet running gears are efficient, use less power, and give a longer service life. Injection molded PPS plastic supplies close tolerances and stability. Compound additives include glass for strength and Teflon(R)* for lubricity.

The PPS pump line was designed with special inert carbon bearings. These bearings are used for maximum chemical compatibility and also serve as thrust flanges and wear plates.

Seal options include packing type or mechanical seals made of ceramic, carbon, Viton(R)* or Teflon(R)*. Grafoil rings, Teflon(R)* lip seal. Shafts are 316 stainless steel or high nickel alloy C. The Teflon(R)* o-rings for positive sealing, independent of internal pump clearances. Also available with close coupled adapter.

Housings	Injection molded reinforced PPS plastic. Glass fibers added for strength and stability.
Gears	Injection molded PPS plastic for close tolerances and stability. Compound additives include glass for strength and Teflon for lubricity. Plastic gears are quiet, efficient, use less power and give longer service life.
Bearings	Carbon sleeve bearings for maximum chemical compatibility also serve as thrust flanges and wear plates.
Seals	Options include packing type Grafoil rings, Teflon(R)* lip seal, or mechanical seals made of ceramic carbon, Viton(R)*, and Teflon(R)*.
Shafts	316 stainless steel or high nickel alloy 'C'.
Sealing	O-rings made from Viton(R) or Teflon(R) for positive sealing, independent of internal pump clearances.

*Viton(R) or equivalent FKM will be used. Viton(R) is a registered trademark of DuPont Dow Elastomers. Teflon(R) or equivalent PTFE will be used. Teflon(R) is a registered trademark of DuPont.

Specifications subject to change without notice.

PPS PUMPS



OBERDORFER PUMPS
A Subsidiary of Thomas Industries Inc.

205 SERIES

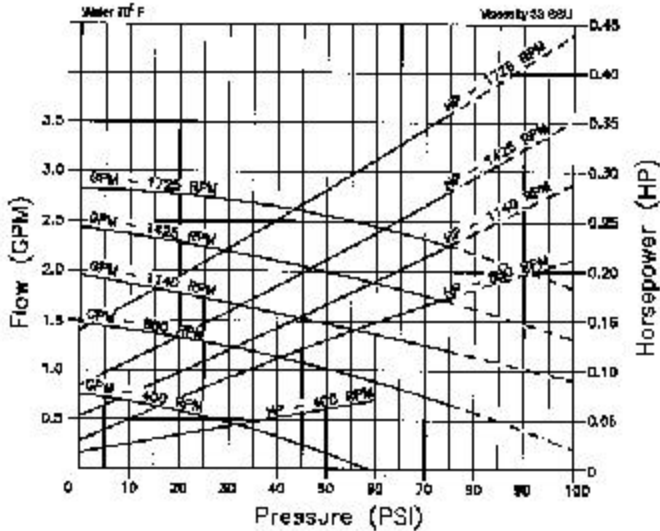

207 SERIES

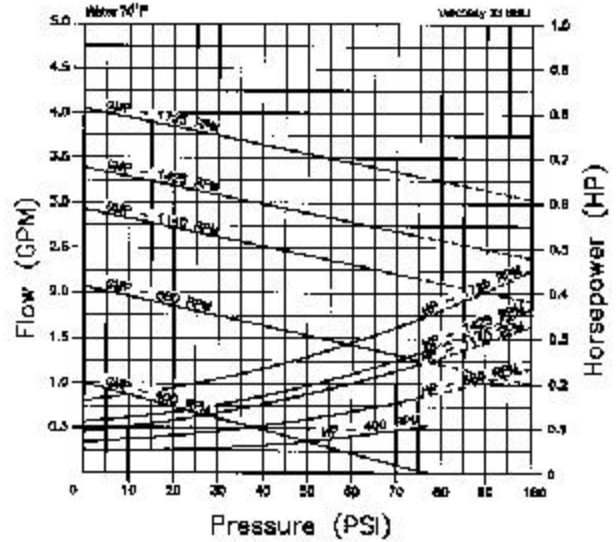

Note: Dotted lines (---) recommended for intermittent duty only due to accelerated wear at higher speeds & pressures.

214 SERIES

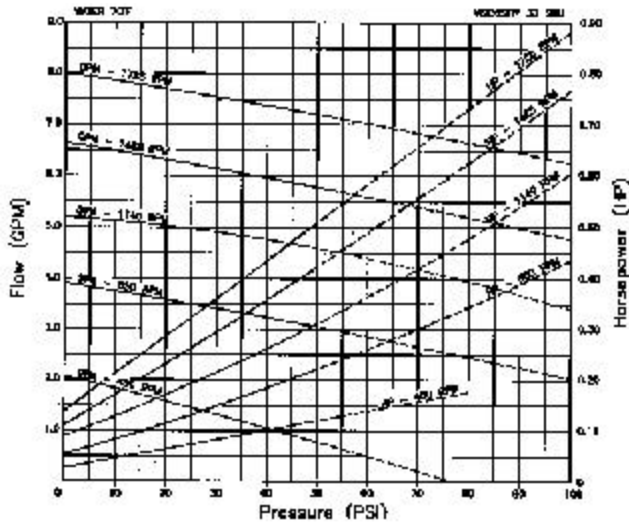

DIMENSIONS

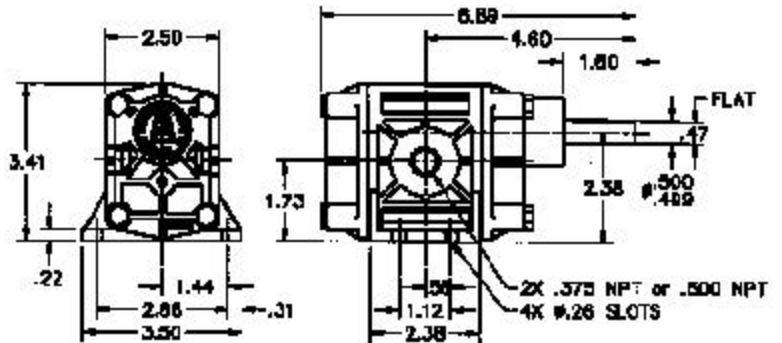

* Also available in 1/2" NPT for all pumps and 3/4" NPT for 214 series

Also available with close coupled adapter for NEMA motor frames.

NOTE: Dimensions are not to be used for construction purposes.

The recommended drive arrangement is direct drive between pump and motor using a flexible coupling (in-line drive). If a pulley drive is required, a separate pillow block bearing is necessary to absorb the belt tension. consult factory for applications beyond the above specifications or for product options not shown.

AN INTERESTING APPLICATION

One of our more inventive distributors asked us to design a PPS pump with at least 13 GPM capacity. He uses these pumps to pump a very cold liquid that is used to keep fish fresh as part of an onboard commercial fishing vessel system. Originally the distributor used one motor and one speed control to drive two of our pumps. The pump closest to the motor had a through drive shaft. One end of the drive shaft was coupled to the motor and the other end was coupled to the second pump. Pictured to the left, is the tandem PPS pump that we at Oberdorfer Pumps designed to replace the two pumps. This saves money, space, and provides for a very flexible system. Come to us with your unique needs. We'll work with you.

