

BRONZE ROTARY GEAR PUMPS CARBONATOR MOTOR MOUNTED

MODEL
N61K10G01



OBERDORFER PUMPS
A Subsidiary of Thomas Industries Inc.

3/8" NPT PORTS

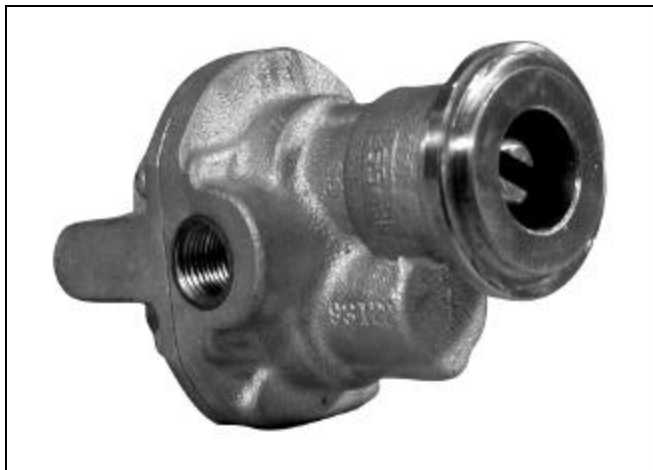

FEATURES:

- n Bronze Body
- n Helical Gears for Quiet Operation
- n Self-lubricating Carbon Bearings
- n Buna N Lip Seal
- n Carbonator Motor Mount

GENERAL DESCRIPTION

The carbonator motor mounting uses a circular clamp, similar to a hose clamp, as means of attaching the pump to a specially machined hub on the motor. This concept was first developed for the vending machine industry to pump carbonated beverages in soft drink dispensers. The main advantages are compactness and economy due to the elimination of the adapter casting.

The rotary gear pump features an all bronze design and 303 stainless steel shafts with options of non-metallic gears and a variety of shaft seals. The built-in relief valve is available in two options; internal recirculation to suction side or external connection for return line to supply tank.

SUCTION LIFT

For a first start-up, the pump should be primed to avoid dry running. Gear pumps are self-priming, but a foot valve with strainer is recommended at the beginning of the suction line. This will keep the gear chamber primed to insure instant flow when the pump is started. maximum suction lift is 20 feet. The suction line should be as short as possible.

PERFORMANCE

Capacity - Water 60° F 1725 R.P.M.

Pump Series	PSI	2	20	40	60	80	100
N61	GPM	2.1	1.9	1.8	1.7	1.6	1.5

LIQUIDS AND TEMPERATURE

Bronze pumps are suitable for water, oil, and mild chemicals in the pH-range from 4-10. Viscous liquids may be handled with carbonator pumps up to a viscosity of 300 SSU. Higher viscosities require a pump speed lower than 1725 RPM, which is currently not available in carbonator motors.

Liquids containing abrasives, solids, powders or pigments are highly detrimental to pump life and must be avoided. The recommended liquid temperature range is from 32°F to 140°F. If more extreme temperature conditions exist, factory should be consulted. Allowing the liquid to freeze in the pump can cause damage.

ROTATION AND RELIEF VALVE

The relief valve is not intended to be a metering or flow control device. Its main purpose is to function as a discharge pressure relief when the spring tension is exceeded by the discharge pressure. Overheating can occur within 5-10 minutes if the discharge line is completely shut off for extended periods.

Unless otherwise specified, the pump motor unit is supplied by the factory for shaft rotation clockwise from shaft end. Reversing the motor rotation will reverse the "in" and "out" ports and also requires changing the relief valve location. The relief valve is always on the discharge side in this pump series. The factory pressure setting is 50 PSIG. To increase pressure, turn the relief valve adjusting screw in a clockwise direction.

To reverse single phase motors, find instructions on the inside of the junction box cover or on the name plate of the motor.

FOR INFORMATION ON OTHER MODELS IN THE N61 SERIES, CONTACT FACTORY.

**MODEL
N61K10G01**

BRONZE ROTARY GEAR PUMPS CARBONATOR MOTOR MOUNTED

OBERDORFER PUMPS
A Subsidiary of Thomas Industries Inc.

DIMENSIONS

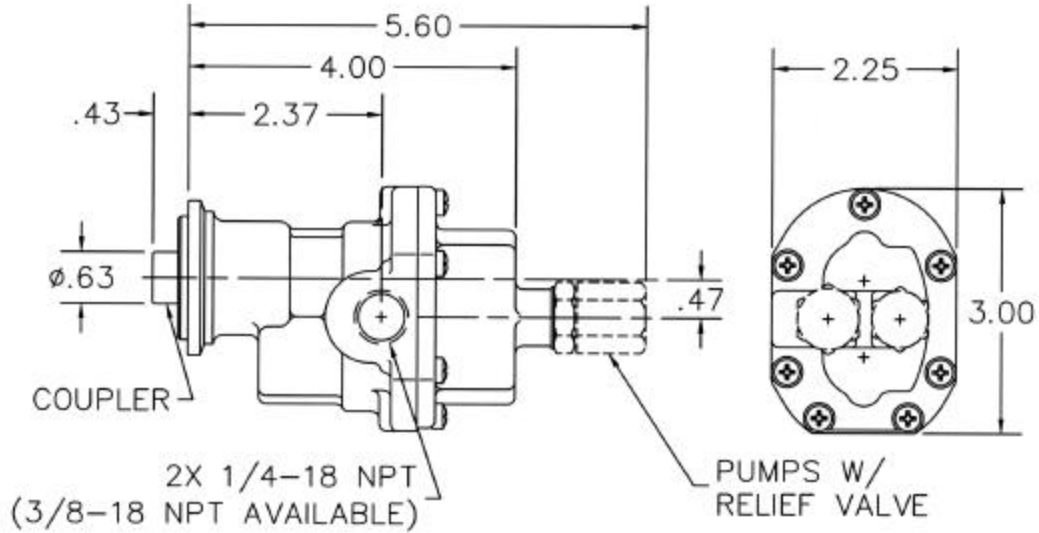

Specifications are subject to change without notice.

EXPLODED VIEW AND PARTS LIST

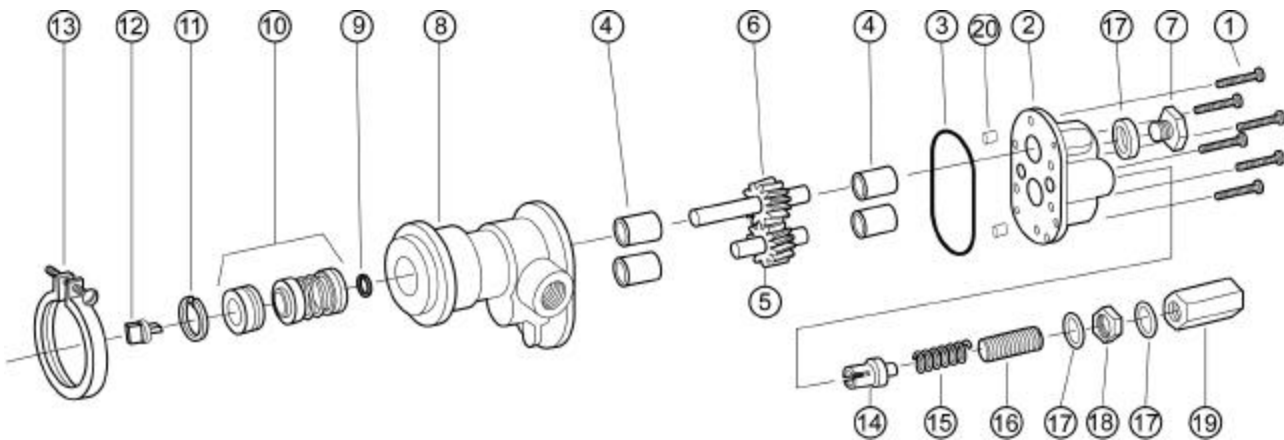

Pump Model	1	2	3	4	5	6	7	8	9	10	11	12	13	14	15	16	17	18	19	20	Repair Kit ¹
	Screw	Cover	O-Ring	Bearing	Idle Gear Assy.	Drive Gear Assy.	Plug Nut	Body	Snap Ring	Seal	Snap Ring	Coupler	Clamp	Poppet/ Ball	Spring	Adjust. Screw	Fiber Washer	Lock Nut	Valve Nut	Dowel Pins	
N61K10G01	(7) 5385	(1) 9314NN5N	(1) 9797-033	(2) 5024	(1) 32979	(1) 32987	(1) ---	(1) 9312NC2N	(1) ---	(1) 5007	(1) ---	(1) 9036	(1) 8840	(1) ---	(1) ---	(1) ---	(3) ---	(1) ---	(1) ---	(2) 8885	11626

¹Repair Kit includes items 3,4,5,6,10 and 12