

BRONZE PEDESTAL ROTARY GEAR PUMPS



OBERDORFER PUMPS
A Subsidiary of Thomas Industries Inc.

MODELS
N13HDP
N13HDL
N13HDM

1 1/2" NPT PORTS

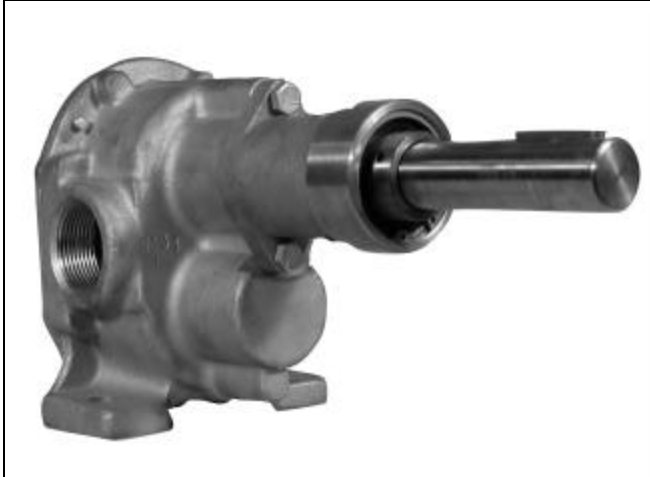

STANDARD			
Pump No.	SEAL		Conversion Kit No.
	Type	Material	
N13HDP	Packing	Acrylic-Graphite	11021
N13HDL	Lip	Viton(R)* -Teflon(R)*	11023
N13HDM	Mechanical	Buna N-Ceramic	11025
SPECIAL			
Pump No.	SEAL		Conversion Kit No.
	Type	Material	
N13HDP-1	Packing	Teflon(R)*	11022
N13HDLS3	Lip	Buna N	11024
N13HDM57	Mechanical	Viton(R)*-Ceramic	11026

FEATURES

- g All Bronze Castings and Stainless Steel Shafts
- g Sealing Arrangement Interchangeable in Field with Proper Kit
- g Outboard Ball Bearing Support for Belt Drive Applications
- g Self Lubricating Carbon Bearings

SERVICE WEAR FACTORS

SPEED - High speed accelerates wear. For longer service life, keep speed as low as possible. Pump speeds above 900 R.P.M. not recommended except for intermittent duty and pressures below 100 p.s.i.

PRESSURE - High pressure accelerates wear. For longer service life keep pressure as low as possible.

LIQUID TEMPERATURE - High temperature accelerates wear. Keep as close to room temperature as possible.

LIQUID CONTAMINATION - Impurities like fine abrasive silt or sand accelerate wear. Keep liquid as clean as possible.

LIQUID LUBRICITY - Lubricants increase service life many fold. Use lubricant additives whenever possible.

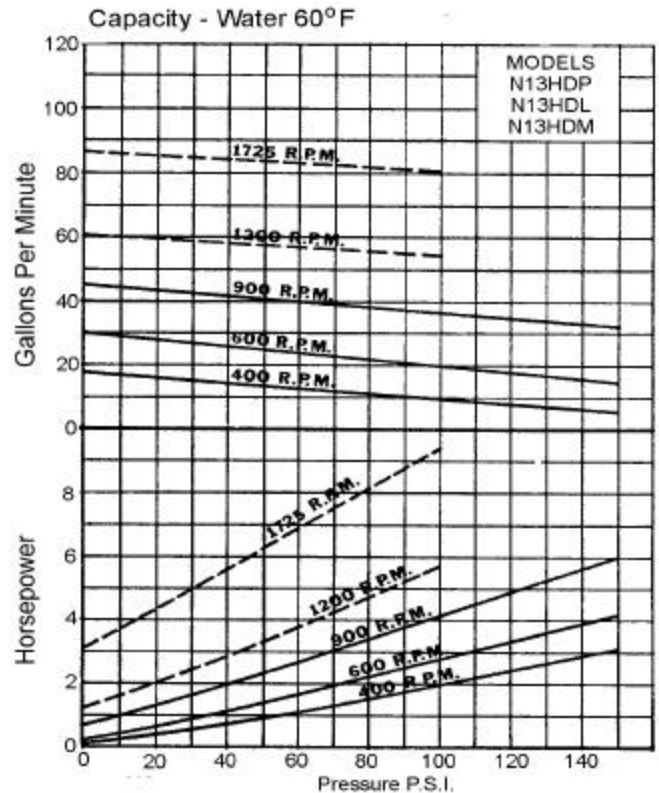

Note: Dotted lines(---) recommended for intermittent duty only due to accelerated wear at higher speeds and pressures.

NOISE - Large gear pumps are inherently noisy due to metal to metal gear contact. Make installations far removed from offices or other relatively quiet people areas. Some noise reduction can be realized by lowering pump speed and use of isolation mounts and lines, usually the small amount of noise reduction achieved does not justify the effort and expense.

DRIVE & ALIGNMENT- Direct drive is the recommended drive arrangement. This pump is suitable for belt drive applications without needing pillow block bearings to achieve acceptable pump life. Correct alignment is absolutely essential for satisfactory pump life. Recheck alignment after piping has been connected to the pump. Electric clutch versions available.

SEAL CONVERSION KITS

Seal conversion kits, illustrated (on back) are designed for quick removal and replacement. In each case, seal housings are fastened to pump bodies by means of 2 bolts, item 13. **IMPORTANT** - before attempting to remove a seal housing containing seal components by sliding them off the pump shaft, be sure to unlock the 2 set screws locking the ball bearing inner race to the pump shaft. The ball bearing is identified as item 20. Also, before attempting to slide the seal housing from the pump shaft, remove all burrs, scale, and projections that could be formed by fretting corrosion.

* Viton(R)* is a registered trademark of DuPont Dow Elastomers. Viton(R) or equivalent FKM will be used.
Teflon(R)* is a registered trademark of DuPont. Teflon(R) or equivalent PTFE will be used.

MODELS
N13HDP
N13HDL
N13HDM

BRONZE PEDESTAL ROTARY GEAR PUMPS



OBERDORFER PUMPS
A Subsidiary of Thomas Industries Inc.

EXPLODED VIEW AND PARTS LIST

Pump No.	1	2	3*	4*	5*	6*	7*	8*	9*	10	11*	12*	13
	Cover	Screw	Snap Ring	O-Ring	Bearing	Drive Gear	Drive Shaft	Idle Shaft	Idle Gear	Body	O-Ring	Packing Ring	Screw
	1 Req'd	8 Req'd	4 Req'd	1 Req'd	4 Req'd	1 Req'd	1 Req'd	1 Req'd	1 Req'd	1 Req'd	1 Req'd	4 Req'd	2 Req'd
N13HDP	9333NN5N	5393	7651	9797-158	5108	9854	7570	7653	9855	9332NH7N	6515	7624	5916
N13HDL	9333NN5N	5393	7651	9797-158	5108	9854	7570	7653	9855	9332NH7N	6515	---	5916
N13HDM	9333NN5N	5393	7651	9797-158	5108	9854	7570	7653	9855	9332NH7N	6515	---	5916

Pump No.	14	15	16	17	18*	19	20	21	22*	23	24	25*	26	Repair Kit No.*
	Nut	Gland	Screw	Seal Housing	Lip Seal	Snap Ring 2 Req'd (P)	Ball Bearing	Key	Lip Seal	Seal Housing	Ring	Seal Assembly	Dowel Pin	
	2 Req'd	1 Req'd	2 Req'd	1 Req'd	1 Req'd	1 Req'd (L&M)	1 Req'd	3 Req'd	1 Req'd	1 Req'd	1 Req'd	1 Req'd	2 Req'd	
N13HDP	5597	7451	6743	7449	6710	7372	7368	5975	---	---	---	---	8597	11009
N13HDL	---	---	---	---	---	7372	7368	5975	7262	7365	---	---	8597	11011
N13HDM	---	---	---	---	---	7372	7368	5975	7262	7365	7651	32315	8597	11013

* Repair Kits include parts 3, 4, 5, 6, 7, 8, 9, 11, 12, 18, 22 & 25

VARIATIONS

Pump No.	12*	22*	25*	Repair Kit
	Packing Ring	Lip Seal	Seal Assy.	
	4 Req'd	1 Req'd	1 Req'd	
13HDP-1	7450	---	---	11010
N13HDLS3	---	6500	---	11012
N13HDM57	---	---	32372	11014

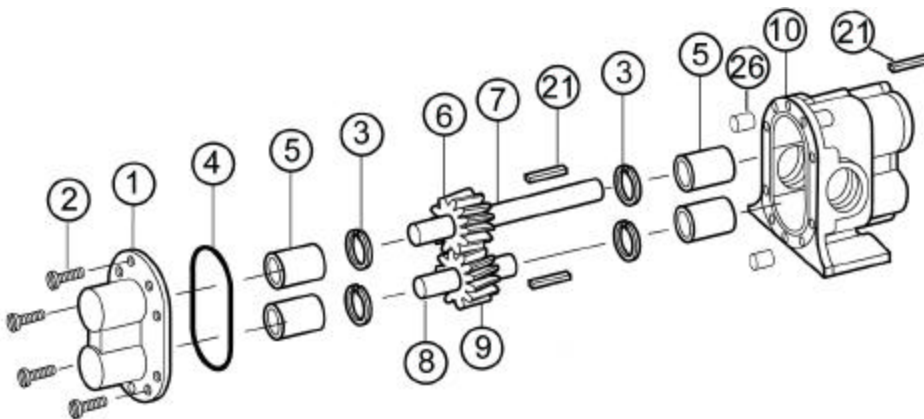

PACKING SEAL END

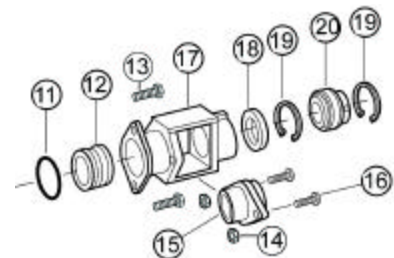

LIP SEAL END

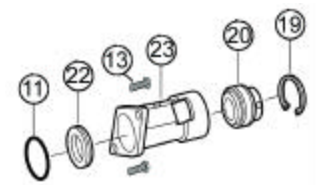

MECHANICAL SEAL END

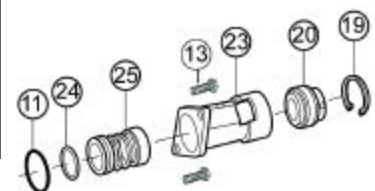

DIMENSIONS

