

BRONZE CLOSE COUPLED ROTARY GEAR PUMPS



OBERDORFER PUMPS
A Subsidiary of Thomas Industries Inc.

**MODEL
N1100
SERIES**

MODEL N1100 - 1 1/4" NPT PORTS



Refer to Model No. N11HDL for pedestal model and performance at different speeds.

Pump No.	Description
N1100	Pump Only
N1100W	Pump, bracket and hardware for mounting to 56C frame motors
N1100X	Pump, bracket, and hardware for mounting to the following motor frames: 143TC, 145TC, 182C, 184C
N1100Y	Pump, bracket, and hardware for mounting to the following motor frames: 182TC, 184TC, 213C, 215C
N1100Z	Pump, bracket, and hardware for mounting to the following motor frames: 213TC, 215TC

1140 RPM

Water 70° F

PSI	GPM	HP REQ.	HP Motor	Motor Frame	Pump & Motor No.	
					Single Ph.	Three Ph.
0	40	0.8	1	145TC	N1100XN46	N1100XN96
10	39	0.9				
20	38	1.1	1 1/2	145TC	N1100XT46	N1100XT96
30	37	1.4				
40	36	1.7	2	184TC	N1100YW46	N1100YW96
50	35	2				
60	34	2.3				
70	33	2.6	3	213TC	N1100ZY46	N1100ZY96
80	32	2.8				
90	31	3.2				
100	30	3.5	5	213TC	---	N1100ZX96
125	28	4.3				
150	25	5				

Note: Motors listed have O.D.P. enclosures and the following electrical requirements:
Single Phase: 115/230V, 60HZ
Three Phase: 230/460V, 60HZ

FEATURES

- n Bronze Construction with Stainless Steel Shafts
- n Positive Spring Loaded Lip Seal made from Viton(R)*
- n Available with Motor Adapter and Hardware
- n Easy Field Assembly to Motors
- n Self-Lubricating Carbon Bearings
- n Consult Factory for Special Motors

DRIVE

The pump is driven directly from the electric motor shaft by means of a flexible coupling. An aluminum adapter connects the pump to the motor.

LIQUIDS AND TEMPERATURE

Service life will be increased substantially if liquid pumped is clean and has lubricity value. These pumps have extremely close tolerance. Fine abrasives like sand, silt, or powders in suspension will destroy pumping ability.

Liquids compatible with bronze, stainless steel, and a Viton(R)* lip seal can be pumped. Check a chemical compatibility chart or Oberdorfer factory.

Temperature extremes are detrimental to service life and should be avoided. Temperature range for this pump is from -40°F to 300°F. Freezing liquid in the pump can deform or damage the pump.

SUCTION LIFT

A rotary gear pump is capable of lifting water on the suction side as high as 20 feet. Though gear pumps are self-priming, a foot valve is recommended. If possible, wet gears with the liquid to be pumped for the first dry start. Liquid retained in the system and gear chambers serves to wet the pump on subsequent starts.

ROTATION

The pump or pump/motor unit is supplied by the factory for shaft rotation in either direction. Reversing the motor rotation will reverse the "in" and "out" ports.

To reverse single phase motors, find instructions on the inside of junction box cover or on name plate of motor.

Three phase motors are not wired for any particular rotation. They can be reversed by interchanging any 2 wires of the 3 wire leads.

*Viton(R) or equivalent FKM will be used. Viton(R) is a registered trademark of DuPont Dow Elastomers.

**MODEL
N1100
SERIES**

**BRONZE CLOSE COUPLED
ROTARY GEAR PUMPS**



OBERDORFER PUMPS

A Subsidiary of Thomas Industries Inc.

EXPLODED VIEW

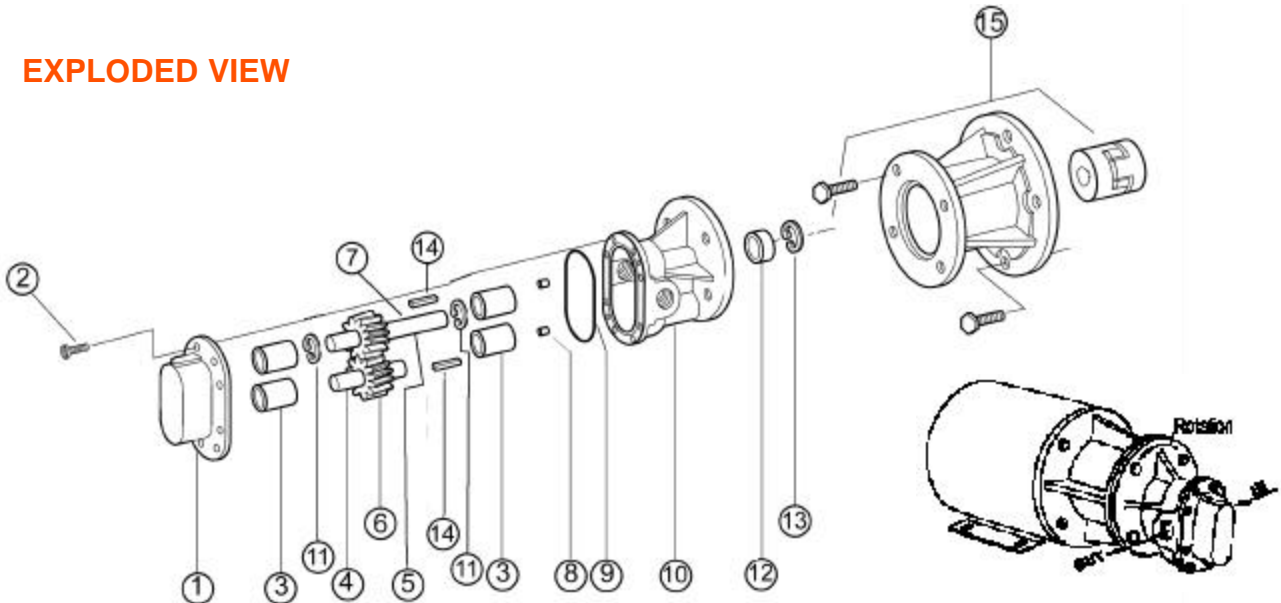

Pump No.	1	2	3 ¹	4 ¹	5 ¹	6 ¹	7 ¹	8	9 ¹	10	11 ¹	12 ¹	13 ¹	14 ¹	15
	Cover	Cover Screws	Bearing	Idle Shaft	Drive Shaft	Idle Gear	Drive Gear	Dowel Pins	O-Ring	Body	Ret. Ring	Lip Seal	Ret. Ring	Key	Adapter Kit
	1 Req'd	8 Req'd	4 Req'd	1 Req'd	1 Req'd	1 Req'd	1 Req'd	2 Req'd	1 Req'd	1 Req'd	4 Req'd	1 Req'd	1 Req'd	2 Req'd	See Below
N1100	9333NN5N	5393	5108	7652	8720	9834	9833	8597	9797-158	9330NG3N	7651	7262	7345	6518	Below

¹ Repair Kit #11581 contains items 3, 4, 5, 6, 7, 9, 11, 12, 13 & 14

Basic pump model number N1100 must be matched to appropriate motor adapter kit listed as W, X, Y, Z kits as required by motor frame size. The final model number is formed by adding codes together in a building block fashion.

Example:

1) Find pressure/flow, required HP, suggested motor frame size (see front) single or (3) phase.

ex: 35 GPM@ 50 PSI requires 2HP, 184TC frame motor

2) Pump/Adapter/Motor Model No:

EXAMPLE:

N1100	Y	W96
Basic Pump	Mounting Adapter Kit (fits 184TC Motor Frame)	2HP 3 Phase Motor Code

Motor Mounting Adapter Kits (Item 15)

Kit Code	Kit No.	Will Fit NEMA Motor Frames	Motor Flange Dia. Ref.	Motor Shaft Dia. Ref.	"A"	"B"
W	11617	56C	4.5"	5/8"	7.56"	10.68"
X	11608	143TC, 145TC, 182C, 184C	4.5"	7/8"	7.56"	10.68"
Y	11609	182TC, 184TC, 213C, 215C	8.5"	1 1/8"	8.59"	11.71"
Z	11610	213TC, 215TC	8.5"	1 3/8"	8.59"	11.71"

MOTOR DATA

Horse Power	Motor Code	Single Phase Part No.	Three Phase Part No.	NEMA Frame Size
1	N46	8478	---	145TC
	N96	---	8480	145TC
1 1/2	T46	8549	---	145TC
	T96	---	8486	145TC
2	W46	8548	---	184TC
	W96	---	8490	184TC
3	Y46	5846	---	213TC
	Y96	---	8547	213TC
5	X96	---	8687	213TC

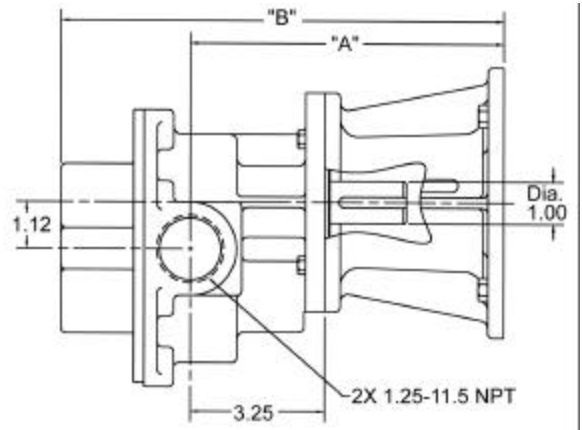
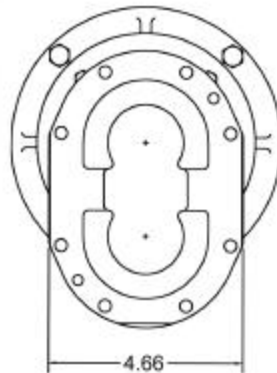

Specifications are subject to change without notice.