

BRONZE OR ALUMINUM CLOSE COUPLED CENTRIFUGAL PUMP

MODEL
830B

 OBERDORFER PUMPS
A Subsidiary of Thomas Industries Inc.

PIPE SIZE: INLET 1 1/2", OUTLET 1 1/4"

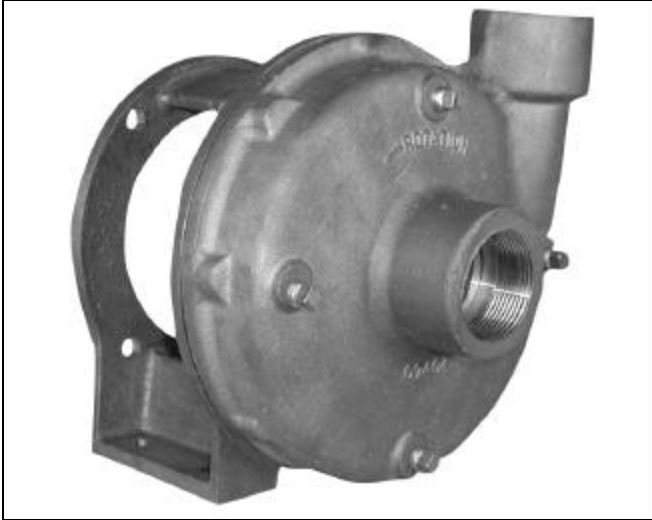

FEATURES

- n Bronze or Aluminum Construction
- n Carbon Face Mechanical Pump Seals
- n Viton(R)* (S10) or Teflon(R)* (S11) Pump Seals Available for Solvent Transfer
- n Field convertible to pedestal drive model
- n Will Handle Contaminated Liquids
- n Extremely Quiet
- n Pump-heads only easily field mounted to standard "C" flange motors

LIQUIDS

The special pump alloys used provide corrosion resistance to many liquids including water, water solutions, and a wide range of commercial chemicals. Questions as to the chemical compatibility of special liquids should be referred to the factory.

Viscous liquids with a maximum viscosity of 2000 Saybolt Seconds Universal can be pumped. However, when pumping viscous liquids as compared with water, a reduction in flow and pressure occurs and the required horsepower rate increases.

Liquids heavier than water require additional horsepower in direct proportion to the increase in specific gravity. Liquids contaminated with small solids or abrasives can be handled, but a reduction in mechanical seal life must be expected.

CHARACTERISTICS

This close-coupled pump uses a standard NEMA C-Flange Jet Pump Motor with weld-on base and threaded shaft end to accept the pump impeller. Single phase motors are non-reversible and are wired for the proper pump rotation

* Viton(R) is a registered trademark of DuPont Dow Elastomers. Viton(R) or equivalent FKM will be used.
Teflon(R) is a registered trademark of DuPont. Teflon(R) or equivalent PTFE will be used.

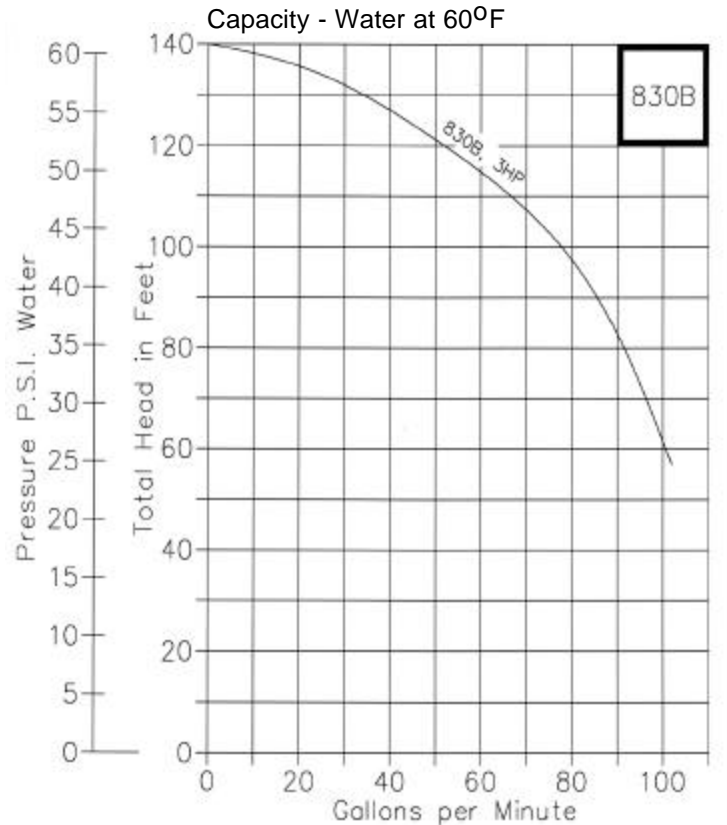

which is counter-clockwise looking at inlet end of pump. See the dimensional drawing on back. Three phase motors must be checked out for proper rotation when pump is installed. Interchanging of any 2 wires in a 3-phase system will reverse motor rotation.

The pump uses a mechanical type shaft seal with a Buna rubber element. It is suitable for water, oils, and some mild solvents and it is limited to 212° F. Viton(R)* seals and Teflon(R)* seals are available for severe solvents, difficult chemicals, and elevated temperatures.

These centrifugal pumps are not self-priming. They must be installed below the liquid level so that the liquid flows to the pump by gravity (flooded suction). However, if a foot valve is used at the beginning of the suction line, and all air is bled from the pump by manual priming, the pump will lift on the suction side up to 15 feet. Such a system relies entirely on the non-leaking foot valve for starting capability.

The flow of a centrifugal pump can be conveniently controlled by a throttling valve in the discharge line without the need for a relief valve. In centrifugal pumps, the horsepower demand will decrease as the pressure increases. Maximum horsepower occurs with a wide open discharge.

**MODEL
830B**

BRONZE OR ALUMINUM CLOSE COUPLED CENTRIFUGAL PUMP



OBERDORFER PUMPS
A Subsidiary of Thomas Industries Inc.

EXPLODED VIEW AND PARTS LIST

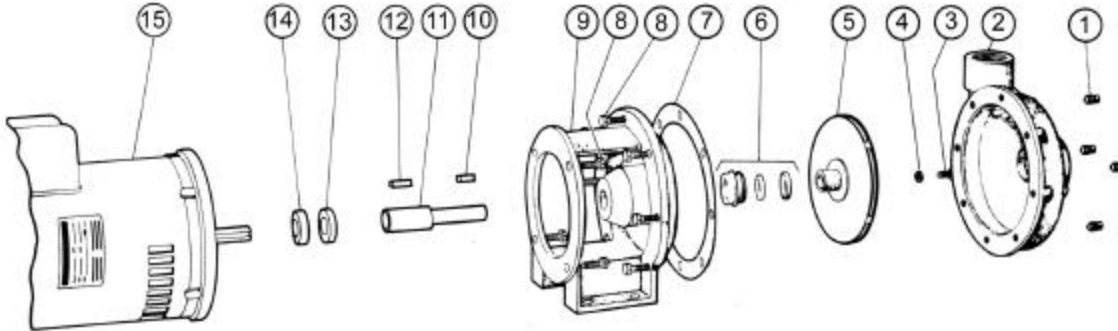

Pump No.	1	2	3	4	5 ¹	6 ¹	7 ¹	8	9	10	11	12	13	14	15	Repair Kit ¹
	Plug	Body	Screw	Lock Wash.	Impeller	Seal Assy.	Gasket	Screw	Adapter	Key	Shaft	Key	Collar	Collar	Motor	
	4 Reqd	1 Reqd	1 Reqd	1 Reqd	1 Reqd	1 Reqd	1 Reqd	12 Reqd	1 Reqd	1 Reqd	1 Reqd	1 Reqd	1 Reqd	1 Reqd	1 Reqd	
830B	5395	7585	7656	7395	32353	32346	7425	5411	7586	7428	7421	6845	5886	7658	---	10953

¹ Repair Kit contains items 5, 6, and 7.

PUMP & MOTOR OPTIONS*

*Note: These are the most frequently used pump and motor combinations. If you have other needs, our sales reps can recommend a pump and motor for your application.

Pump No.	Motor	Part #
830B-Y25	3 HP, 3450 RPM, 115/230v, Single Phase, ODP	7540
830B-Y63	3 HP, 3450 RPM, 220/440v, Three Phase, ODP	7543
830B-Y64	3 HP, 3450 RPM, 220/440v, Three Phase, TEFC	8182

DIMENSIONS

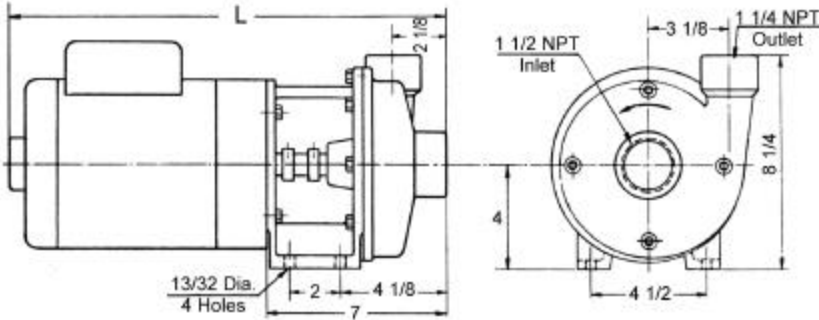

**"L" Dimension for Single phase motors is 19"; for Three phase motors, it is 18"

NUMBERING

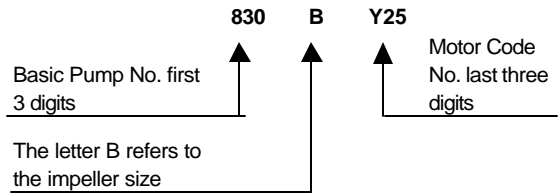

INSTRUCTIONS FOR ASSEMBLING PUMP TO MOTOR

The following instructions apply in cases where a customer chooses to purchase the pump only and supplies his/her own motor for close coupled mounting. The motor must have a NEMA C-Flange, 5/8" diameter straight shaft with 3/16" key, 3450 RPM speed and the horsepower must agree with the pump size as follows:

Pump No. 830, 3 HP

Assemble pump to motor step by step as follows:

- 1) Slide pre-assembled pump with hollow shaft over motor shaft. Insert Key 12.
- 2) Apply an axial push force against screw head in impeller eye (to overcome seal spring tension) while tightening set screws in shaft collars 13 and 14. SEE DIAGRAM.
- 3) Bolt pump to motor flange with four hex. head cap screws 8.

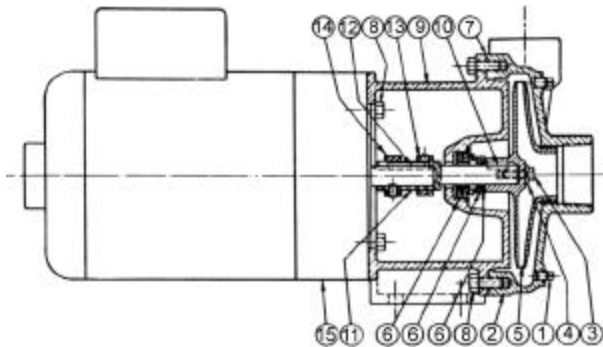

2/01 Specifications are subject to change without notice. All motor dimensions are subject to variations among motor manufacturers.