

BRONZE BASE MOUNTED SELF-PRIMING CENTRIFUGAL PUMP

**MODEL
75PB**



OBERDORFER PUMPS
A Subsidiary of Thomas Industries Inc.

PIPE SIZE 1 1/2"



FEATURES

- n Self Priming to 20 Ft. Suction Lift
- n Heavy Duty Ball Bearings
- n Designed for Pulley Drive Applications
- n Stainless Steel or Monel Shaft (75PB-01)
- n Teflon(R)* Barrier Lip Seal to Protect Motor Bearings
- n Carbon Face Mechanical Pump Seals
- n Viton(R)* (S10) or Teflon(R)* (S11) Pump Seals Available for Solvent Transfer
- n Bronze Models with Monel Shaft Ideal for Marine Service (including air conditioning, bilge, and sea water recirculating)
- n Will Handle Contaminated Liquids

LIQUIDS

The special pump alloys used provide corrosion resistance to many liquids including water, water solutions, and a wide range of commercial chemicals. Questions as to the chemical compatibility of special liquids should be referred to the factory.

Viscous liquids with a maximum viscosity of 2000 Saybolt Seconds Universal can be pumped. However, when pumping viscous liquids as compared with water, a reduction in flow and pressure occurs and the required horsepower rate increases.

Liquids heavier than water require additional horsepower in direct proportion to the increase in specific gravity. Liquids contaminated with small solids or abrasives can be handled, but a reduction in mechanical seal life must be expected.

CHARACTERISTICS

The pump uses a mechanical type shaft seal with a Buna rubber element. It is suitable for water, oils, and some

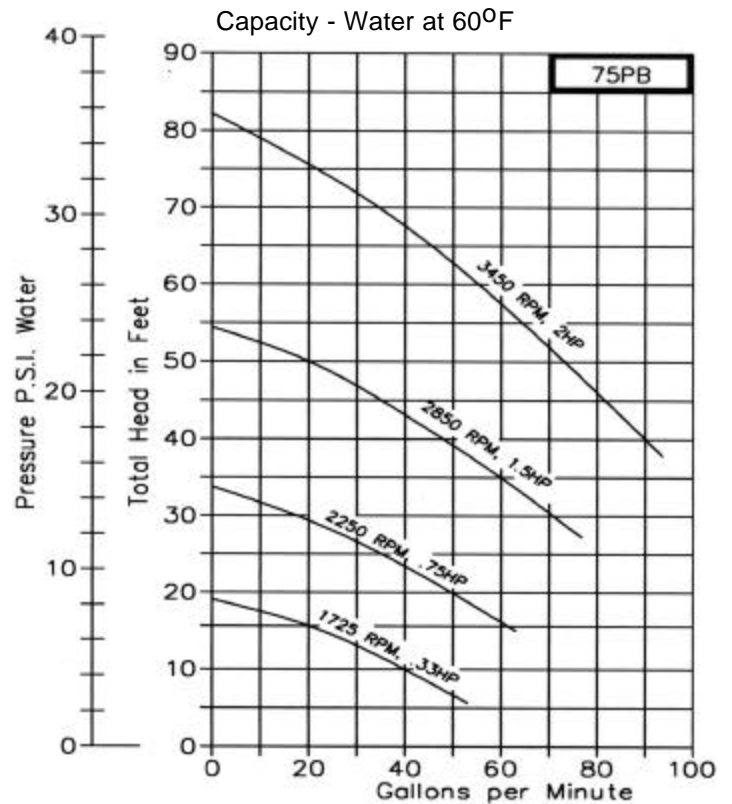

mild solvents and it is limited to 212°F. Viton(R)* seals and Teflon(R)* seals are available for severe solvents, difficult chemicals, and elevated temperatures.

The flow of a centrifugal pump can be conveniently controlled by a throttling valve in the discharge line without the need for a relief (Continued on back)

Capacity Gallons Per Minute (Water) at Various Suction Lifts

Discharge Pressure	Feet	P.S.I.	3450 RPM					2850 RPM				
			Suction Lift					Suction Lift				
			0 Ft.	5 Ft.	10 Ft.	15 Ft.	20 Ft.	0 Ft.	5 Ft.	10 Ft.	15 Ft.	20 Ft.
20	8.7	94	93	92	91	87	87	79	72	64	54	
30	13.0	93	92	91	87	80	71	62	52	38	21	
40	17.3	91	86	81	71	60	54	38	20	---	---	
50	21.7	76	69	60	49	35	22	---	---	---	---	
60	26.0	59	49	37	23	5	---	---	---	---	---	
70	30.5	38	24	8	---	---	---	---	---	---	---	
80	34.6	13	---	---	---	---	---	---	---	---	---	

Discharge Pressure	Feet	P.S.I.	2250 RPM				1725 RPM				
			Suction Lift				Suction Lift				
			0 Ft.	5 Ft.	10 Ft.	15 Ft.	20 Ft.	0 Ft.	5 Ft.	10 Ft.	15 Ft.
5	2.2	64	63	62	53	40	50	43	25	7	---
10	4.3	64	62	53	40	20	41	25	---	---	---
15	6.5	61	53	40	20	---	23	---	---	---	---
20	8.7	50	37	19	---	---	---	---	---	---	---
25	10.8	38	20	---	---	---	---	---	---	---	---
30	13.0	20	---	---	---	---	---	---	---	---	---

* Viton(R) is a registered trademark of DuPont Dow Elastomers. Viton(R) or equivalent FKM will be used.
Teflon(R) is a registered trademark of DuPont. Teflon(R) or equivalent PTFE will be used.

**MODEL
75PB**

BRONZE BASE MOUNTED SELF-PRIMING CENTRIFUGAL PUMP



OBERDORFER PUMPS
A Subsidiary of Thomas Industries Inc.

EXPLODED VIEW AND PARTS LIST

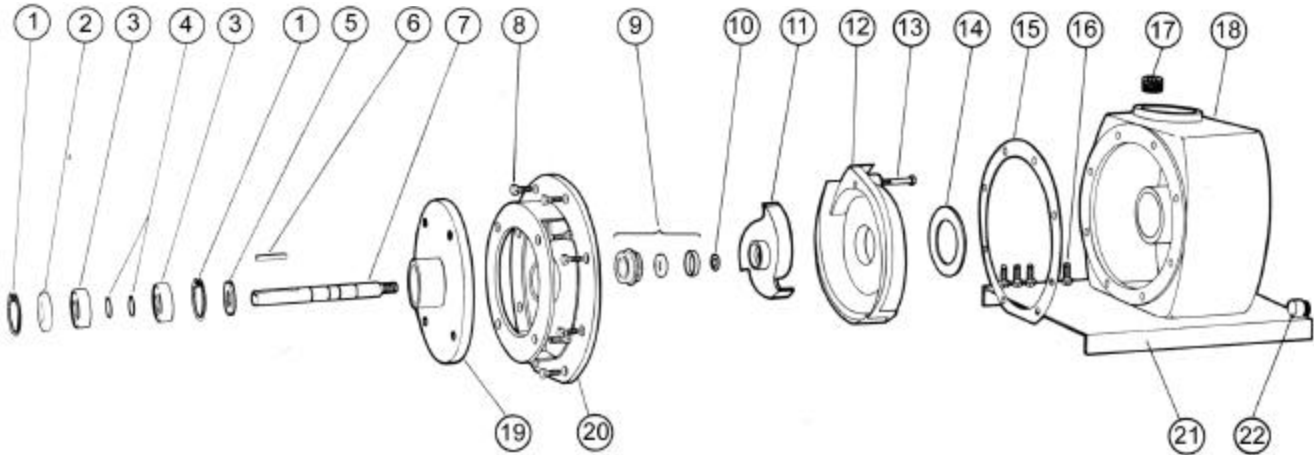

Pump No.	1	2	3	4	5	6	7	8	9 ¹	10	11 ¹
	Ret. Ring	Lip Seal	Ball Bearing	Ret. Ring	Slinger	Key	Shaft	Screw	Seal Assy.	Shim	Impeller
	2 Reqd	1 Reqd	2 Reqd	2 Reqd	1 Reqd	1 Reqd	1 Reqd	12 Reqd	1 Reqd	1 Reqd	1 Reqd
75PB	5925	6609	5928	5926	7447	6567	7037	5411	32155	602502	7927
75PB-01	5925	6609	5928	5926	7447	6567	6890	5411	32155	602502	7927

12	13	14 ¹	15 ¹	16	17	18	19	20	21	22	Repair Kit ¹
Diffuser	Screw	Gasket Diffuser	Gasket Flange	Screw	Plug	Body	Bearing Plate	Adapter	Base	Plug	
1 Reqd	2 Reqd	1 Reqd	1 Reqd	4 Reqd	1 Reqd	1 Reqd	1 Reqd	1 Reqd	1 Reqd	1 Reqd	
7928	7796	7798	7797	7637	7934	7929	7933	7926	6742	7321	11145
7928	7796	7798	7797	7637	7934	7929	7933	7926	6742	7321	11145

¹ Repair Kit contains items 9, 11, 14 & 15.

DIMENSIONS

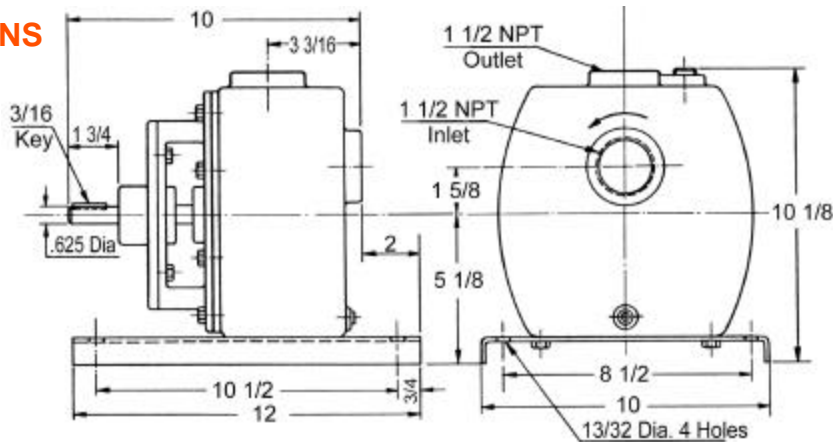

(Continued from front)

valve. In centrifugal pumps, the horsepower demand will decrease as the pressure increases. Maximum horsepower occurs with a wide open discharge.

SUCTION LIFT

Self-priming centrifugal pumps must be primed once at the initial start-up thru the priming plug opening at the top of the pump body. On subsequent starts the pump will automatically prime itself and develop

a lifting capability of 15 feet or more.

The height of the suction lift should be kept to an absolute minimum and the size of the suction pipe should be equal or larger than the pump inlet port. A foot valve with strainer is recommended at the beginning of the suction line. Rotation is clockwise looking from the shaft end. Self-priming centrifugal must be operated with the shaft in the horizontal position. See chart on front.