

BRONZE CLOSE COUPLED CENTRIFUGAL PUMP

MODEL
172B



OBERDORFER PUMPS

A Subsidiary of Thomas Industries Inc.

PIPE SIZE: INLET 3/4", OUTLET 3/4"



172B-A81 Pictured

FEATURES

- n Bronze Casting is resistant to sea water
- n Stainless Steel Shaft for Marine Use
- n Motor is totally enclosed with 9" long vinyl plastic insulated leads
- n Compact
- n Lightweight
- n Mechanical Seal
- n Ideal for:
 - Marine Air Conditioning
 - Engine Block Temperature Control
 - Radiator and Heat Exchanger Circulation
 - Baitwell Circulation

SEAL

The pump uses a mechanical type shaft seal with a Buna rubber element. It is suitable for water, oils, and some mild solvents and is limited to 212°F, Viton (R)* is available for up to 400°F (172B-08).

LIQUIDS

One of the outstanding features of this pump and motor unit is its compact D.C. motor size. Although small in size, adequate motor power is available for pumping water, water solutions, and a wide range of commercial chemicals. Questions as to the chemical compatibility of special liquids should be referred to the factory.

Viscous liquids with a maximum viscosity of 2000 Saybolt Seconds Universal can be pumped. However, when pumping viscous liquids as compared with water, a reduction in flow and pressure occurs and the required horsepower rate increases.

Liquids heavier than water require additional horsepower in direct proportion to the increase in specific gravity.

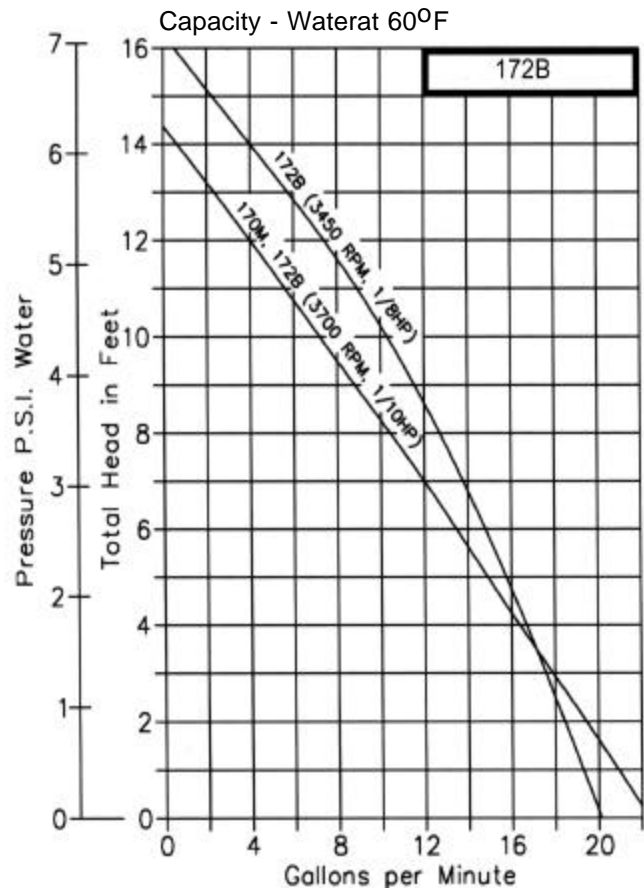

CHARACTERISTICS

Oberdorfer centrifugal pumps have a single rotating impeller. Liquid enters at the center and is thrown outward radially by centrifugal force. The impeller is not in contact with other pump parts resulting in quiet, efficient pumping action. The flow produced is not positive which permits the discharge line to be shut off completely without danger of overloading motors or bursting lines. Consequently, a relief valve is not required.

These centrifugal pumps are not self-priming. They must be installed below the liquid level so that the liquid flows to the pump by gravity (flooded suction). However, if a foot valve is used at the beginning of the suction line, and all air is bled from the pump by manual priming, the pump will lift on the suction side up to 15 feet. Such a system relies entirely on the non-leaking foot valve for starting capability.

The flow of a centrifugal pump can be conveniently controlled by a throttling valve in the discharge line without the need for a relief valve. In centrifugal pumps, the horsepower demand will decrease as the pressure increases. Maximum horsepower occurs with a wide open discharge.

*Viton(R) is a registered trademark of DuPont Dow Elastomers. Viton(R) or equivalent FKM will be used.

**MODEL
172B**

BRONZE CLOSE COUPLED CENTRIFUGAL PUMP



OBERDORFER PUMPS
A Subsidiary of Thomas Industries Inc.

EXPLODED VIEW AND PARTS LIST

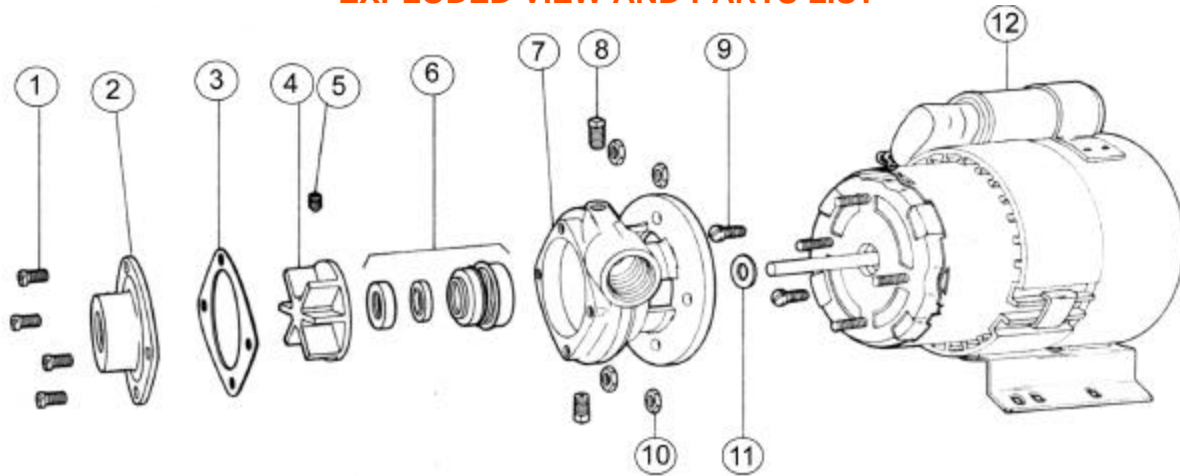

Pump No.	1	2	3 ¹	4 ¹	5	6 ¹	7	8	9	10	11	12	Repair Kit ¹
	Screw	Cover	Gasket	Impeller	Set Screw	Seal Assy.	Body	Plug	Screw	Hex Nut	Slinger	Motor	
	4 Req'd	1 Req'd	1 Req'd	1 Req'd	1 Req'd	1 Req'd	1 Req'd	2 Req'd	2 Req'd	4 Req'd	1 Req'd	1 Req'd	
172B	5385	7375	7020	7678	6079	32458	7456	5395	7424	7686	6651	---	11071

¹Repair kit contains items 3, 4 & 6.

PUMP & MOTOR OPTIONS*

*Note: These are the most frequently used pump and motor combinations. If you have other needs, our sales reps can recommend a pump and motor for your application.

Pump No.	Electric Motor	Part #
172B-A81	1/10 HP, 3700 RPM, 12v, Single Phase, TEFC	9950
172B-A82	1/10 HP, 3700 RPM, 24v, Single Phase, TEFC	9949
172B-A85	1/8 HP, 3700 RPM, 12v DC, TEFC	8101
172B-A86	1/8 HP, 3700 RPM, 24v DC, TEFC	8102
172B-A87	1/8 HP, 3700 RPM, 32v DC, TEFC	8103
172B-B26	1/8 HP, 3450 RPM, 115v, Single Phase, TEFC	8281
172B-B27	1/8 HP, 3450 RPM, 220v, Single Phase, TEFC	8282

DIMENSIONS

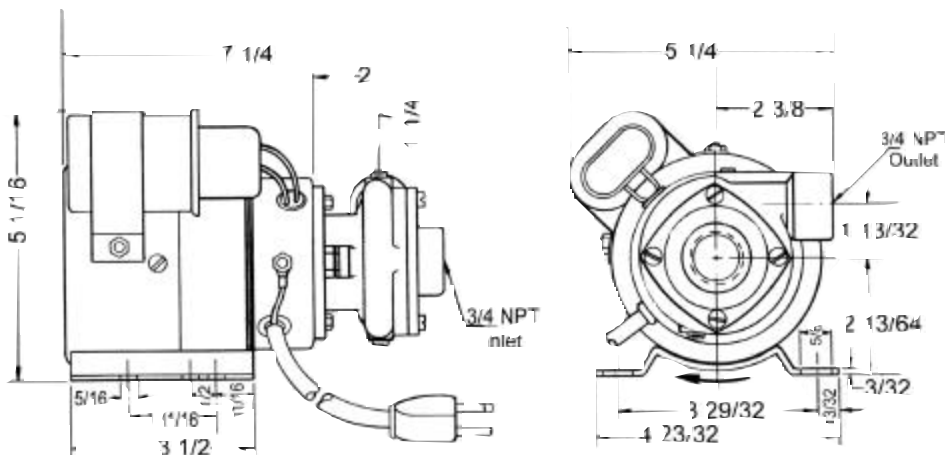

NUMBERING

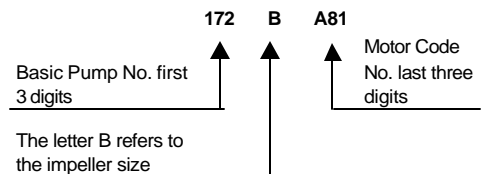

2/01 Specifications are subject to change without notice. All motor dimensions are subject to variations among motor manufacturers.